



BORDIGNON

Air/oil modular minimal system

INSTRUCTION MANUAL



Air/oil modular minimal system

GENERAL DESCRIPTION

The air-oil minimal lubricating system consists of mainly a pressurised tank (L) and one or more mixing modules (N). The lubricant which can be made of a mixture of air and oil or oil only is pressurized by the air and sent to the mixing modules through a pipe inside the tank.

The modules are provided with components that allow them to be controlled independently:

- two screws to adjust oil and air or only oil quantity (G) and to control the lubricant flowing from every single module;
- electrovalves (M) which give the impulse and control the starting and the duration time of the lubrication. These electrovalves can be set independently allowing different lubrication times for each module.

ADVANTAGES

- Easy to install on the machine;
- Reduction in tap wear;
- Improved surface finish on the thread;
- No lubricant residuals left on the part when the work is complete;
- Large spray range;
- Greater safety and environmental hygiene at the workplace;
- Independent control of the modules.



Attention! The unit is supplied without condensate separator and without the pressure reducer needed to control the working pressure of the pump.

DMINPUMP - 1.5 LT TANK / Front and side view

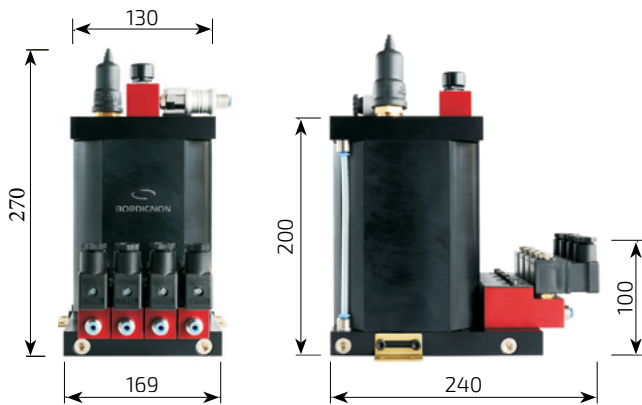

Top view

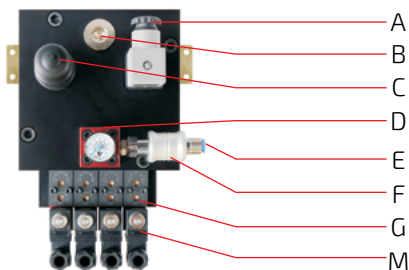

- A:** Minimum electric level
- B:** Loading cap with filter
- C:** Pressure switch
- D:** Pressure gauge
- E:** Air inlet - 6 mm pipe Ø
- F:** Slide valve

DMINPUMP3 - 3.0 LT TANK / Front and side view

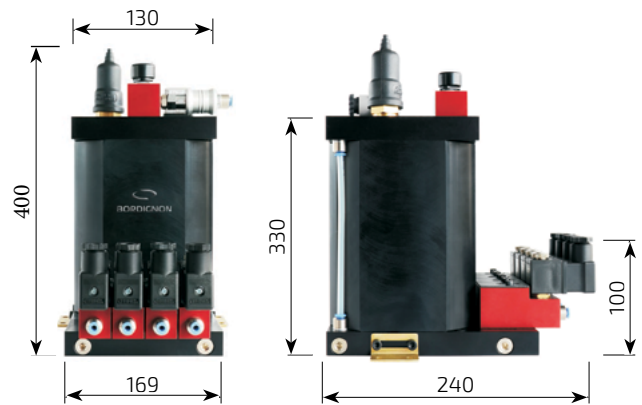

Side view

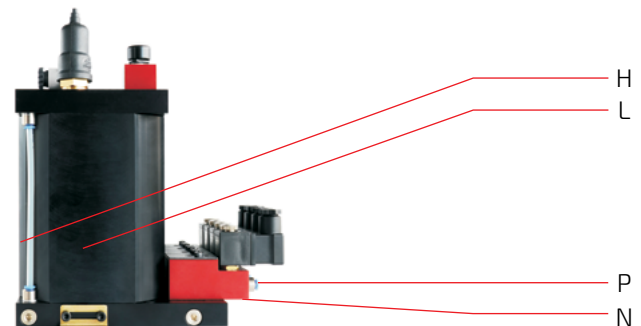

- G:** Lubrication outlet control
- H:** Visible level
- L:** Tank
- M:** Electrovalve
- N:** Module
- P:** Air/oil outlet - 4 mm pipe Ø

TECHNICAL SPECIFICATIONS

	DMINPUMP	DMINPUMP3
Tank capacity	1.5 lt	3.0 lt
Maximum number of modules	4	4
Air inlet pressure	3 bar ÷ 8 Bar	3 bar ÷ 8 Bar
Max. air consumption at the outlet of each module	7.5 l/min.	7.5 l/min.
Air inlet pipe	Ø 6 mm	Ø 6 mm
Air/oil outlet pipe	Ø 4 mm	Ø 4 mm
Oil flow max. rate per element	0.05 l/min. (oil ÷ 25 cSt)	0.05 l/min. (oil ÷ 25 cSt)
Lubricating oil	10cSt ÷ 100cSt	10cSt ÷ 100cSt
Pressure switch calibration	3 Bar	3 Bar
Pressure switch max. load	48 Vac - DC 0.5 A	48 Vac - DC 0.5 A
Level max. load	250 Vdc 1.3 A	250 Vdc 1.3 A
Element electrovalve power supply	24Vdc - 5.5 W	24Vdc - 5.5 W
Operating temperature	+5° ÷ +50°C	+5° ÷ +50°C
Net weight	Kg 5.8	Kg 7.2

TABLE 1

INSTALLATION

Use the brackets with the holes to fix the unit properly (see picture on the side).
It is prohibited to use the unit if submersed in fluids or in particularly aggressive or explosive/inflammable environment.
Use safety gloves or glasses as specified in the safety sheet of the lubricant.
Do not use aggressive lubricants with NBR gaskets.
Do not ignore the hazards to health and comply with the health regulations.

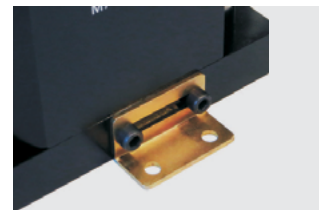

PNEUMATIC CONNECTIONS

Before making the connection, check that the valve for the main air, the manual sliding valve and the air/oil control devices are closed. Make sure that the inlet pressure does not exceed 8 Bar.
Use fittings and pipes that are suitable for the operating pressures.



Warning! Always install a regulator filter with condensate recovery on the air inlet.
Any unfiltered deposits or sediments could irreparably damage the product.

ELECTRIC CONNECTIONS

Pressure switch

N.C. SYMBOL

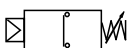

LEVEL



80 W / VA
250 VDC
1.3 A

FILLING THE TANK

Make sure there is no residual pressure in the tank (pressure gauge indicator= "0").
The oil is transferred to the tank through the loading cap (B) with a filter.
Never exceed maximum level on the filling indicator (H).

INTRUCTIONS FOR USE

Operations to perform before start-up:

- Check the integrity of the unit;
- Check the power supply pressure (max. 8 Bar);
- Check that electric connection was carried out correctly;
- Check that the unit is at the operating temperature.

USE

- Adjust the pressure (3-8 Bar);
- Open the manual slide valve (F);
- Check that the electrovalves on the elements are correctly activated;
- At the first start-up, it may be necessary to fill the oil pipes, to activate the electrovalve electrically, wait until the lubricant exits;
- Check that lubrication is suitable.

REGULATION

The modular elements are normally supplied with the oil regulation and the air regulation completely closed.
To regulate the air/oil mixture, turn the oil and air regulation screws on the module. To increase the load turn the screw counterclockwise, to decrease the load turn it clockwise.
When the electrovalve remains excited, the lubricant keeps flowing out.

PROBLEMS AND SOLUTIONS

Anomaly	Cause	Solution
lubrication does not take place activating the electrovalve.	<ul style="list-style-type: none"> — Electrovalve is damaged; — Air supply pressure is below 3 bar; — Lubricant is missing. 	<ul style="list-style-type: none"> — Replace the electrovalve; — Increase the supply pressure (min. 3 Bar); — Top up the tank with lubricant.
Lubricant exits irregularly and with large air bubbles visible in the dia. 4 mm oil pipe.	<ul style="list-style-type: none"> — Lubricant below the minimum level in the tank; — The dia. 4 mm oil pipe is not perfectly engaged the module push-in. 	<ul style="list-style-type: none"> — Top up the tank with new lubricant; — Insert the pipe, making sure to insert it to the end.



Warning! Make sure that the pneumatic and electrical power supply are disconnected before carrying out any maintenance work.

MAINTENANCE PROCEDURES

The following maintenance actions are recommended:

- Periodically check the pipe joints to detect any leaks;
- Periodically check the oil level and fill it if necessary through the loading cap;
- Always keep the modules clean to be able to quickly detect any leaks.

The machine does not require any special equipment for any control and/or maintenance activity. It is recommended to use tools and personal protective devices suitable for use and in good conditions according to current regulations to prevent damage to people or machine parts.

DISPOSAL

During machine maintenance, or if it is demolished, do not dispose of the polluting parts in an improper manner. Refer to the local regulations for their correct disposal.

PRECAUTIONS FOR USE

The warnings about the risks involved in using a unit for lubricants must be carefully read.

The operator must understand its operation and clearly understand the hazards connected to pumping pressurised oils. Therefore we recommend:

- To check the chemical compatibility of the material which this unit is made of with the fluids to be pumped (TABLE 2). An incorrect selection could cause, in addition to damaging the units and pipes, serious risks for people and for the environment;
- Never exceed the max. operating pressure (max. 8 bar) permitted for the unit and the components connected to it;
- Use only original spare parts;
- When replacing some components with others, make sure that they are suitable for operating at the unit's maximum operating pressure.

Note: While operating or during maintenance operation, the operator must use protective devices, garments and tools in compliance with current standards with regard to the location and the use of the unit.



Warning! Never stop or deviate leaks with your hands or other body parts.

Power supply

Do not carry out any work on the machine before disconnecting it from the electrical power supply and make sure that nobody may reconnect it during the operation.

Inflammability

The lubricant used in the lubrication circuit is normally not an inflammable one. In any case it's necessary to adopt all possible measures to prevent that it comes into contact with very hot objects or open flames.

Pressure

Before each operation make sure that in every branch of the lubrication circuit there is no residual pressure that may cause oil to spray when disassembling joints or other parts. After long period of inactivity check the seal of all parts subject to pressure. Avoid violent impacts on joints, pipes and other pressured parts. Damaged flexible pipes or damaged fittings are dangerous and must be replaced with new ones. Only original spare parts should be used.

FLUIDS THAT ARE NOT PERMITTED

Fluids	Risks
Lubricants with abrasive additives	Wear of internal components
Lubricants with silicone additives	Seizure
Petrol - solvents - inflammable liquids	Fire - explosion - damage to the gaskets
Corrosive products	Corrosion - damage to people
Water	Unit oxidation
Food substances	They would be contaminated

TABLE 2

NOTE:

The warranty does not cover equipment that been modified, tampered with or altered without authorization. Nor does it cover the product having damages or injuries resulting from misuse, neglect, normal expected wear, chemical corrosion, improper installation or operation contrary to factory recommendation.

BORDIGNON SRL / COMMERCIAL OFFICE

Via Volta 20 - 36028 Rossano Veneto (VI) Italy

T +39 0424 36157 - F +39 0424 382359

bordignon@bordignon.com

PRODUCTION / TECHNICAL OFFICE

Via Volta, 2 - 36028 Rossano Veneto (VI) Italy

T +39 0424 540311 - F +39 0424 541113

b.simone@bordignon.com

Bordignon Srl reserves the right to make modifications to the technical data of this manual, without prior notice.