

AutomotiveLine

NITROGEN GAS SPRINGS FOR PRESS TOOLS, DIES AND MOULDS
RESSORTS À GAZ POUR OUTILS DE PRESSE, MATRICES ET MOULES



BORDIGNON

Where innovation happens

www.bordignon.com

WHERE
INNOVATION
HAPPENS



Index

Sommaire

Introduction - <i>Introduction</i>	04
Our company - <i>Notre entreprise</i>	05
Power & compactness - <i>Puissance et compacité</i>	06
Durability, reliability, cost reduction - <i>Durabilité, fiabilité, réduction des coûts</i>	07
Safety & reliability - <i>Sécurité et fiabilité</i>	08
FMEA & Safety protections - <i>AMDEC et protections de sécurité</i>	10
Use instructions - <i>Mode d'emploi</i>	12
Information & catalogue help - <i>Informations et aide sur le catalogue</i>	13
Nitrogen gas springs for press tools, dies and moulds - <i>Ressorts à gaz pour outils de presse, matrices et moules</i>	14
EGS series nitrogen gas ejectors - <i>Éjecteurs d'azote gazeux série EGS</i>	16
VGS series nitrogen gas springs - <i>Ressorts à gaz à l'azote série VGS</i>	20
AGS series nitrogen gas springs - <i>Ressorts à gaz à l'azote série AGS</i>	24
TGS series nitrogen gas springs - <i>Ressorts à gaz à l'azote série TGS</i>	34
IGS series nitrogen gas springs - <i>Ressorts à gaz à l'azote série IGS</i>	38
LGS series nitrogen gas springs - <i>Ressorts à gaz à l'azote série LGS</i>	46
PGS series nitrogen gas springs - <i>Ressorts à gaz à l'azote série PGS</i>	50
VV series nitrogen gas springs - <i>Ressorts à gaz à l'azote série VV</i>	58
Fixing accessories - <i>Accessoires de fixation</i>	62
Accessories for linked system - <i>Accessoires pour système lié</i>	78
Accessories for charging and discharging - <i>Accessoires pour la charge et la décharge</i>	100
Gas springs and accessories for "OV system" - <i>Ressorts à gaz et accessoires pour « système OV »</i>	106
Other accessories - <i>Autres accessoires</i>	110

Automotive line: flexibility and performance for the manufacturers worldwide

Automotive line: flexibilité et performance
pour les constructeurs du monde entier

Through our long-term and close collaboration with the manufacturers of the automotive market, we are familiar with their needs. That's why we have created a line of gas springs and accessories that combines performance, flexibility and optimization.

Grâce à notre collaboration étroite et à long terme avec les constructeurs du marché automobile, nous connaissons leurs besoins. C'est pourquoi nous avons créé une gamme de ressorts à gaz et d'accessoires qui allient performance, flexibilité et optimisation.

The Bordignon nitrogen gas springs, if properly used, will last more than 200,000,000 mm of total stroke in normal working conditions.

Les ressorts à gaz azotés Bordignon, s'ils sont correctement utilisés, dureront plus de 200.000.000 mm de course totale dans des conditions de travail normales.



* ISO 9001 certificate available for download on www.bordignon.com

Certificat ISO 9001 disponible en téléchargement sur www.bordignon.com



A pioneering approach extending the boundaries

Une approche pionnière qui repousse les limites

Starting 60 years ago, Bordignon succeeded in becoming the leading company in the reference market, developing new technological solutions applied to springs, nitrogen gas springs and solutions for press tools, dies and moulds.

Our vision about business investments aims to mainly focus on research and development, and at the same time it guarantees the highest standards of products quality and performance, thanks to highly specialised manpower and to the innovative technologies that characterise our production plants.

Depuis 60 ans, Bordignon a réussi à devenir l'entreprise leader sur le marché de référence, en développant de nouvelles solutions technologiques appliquées aux ressorts, aux ressorts à gaz azoté et aux solutions pour outils de sertissage, matrices et moules.

Notre vision des investissements commerciaux vise à se concentrer principalement sur la recherche et le développement, tout en garantissant les normes les plus élevées de qualité et de performance des produits, grâce à une main-d'œuvre hautement spécialisée et aux technologies innovantes qui caractérisent nos usines de production.

Power & compactness

Puissance et compacité

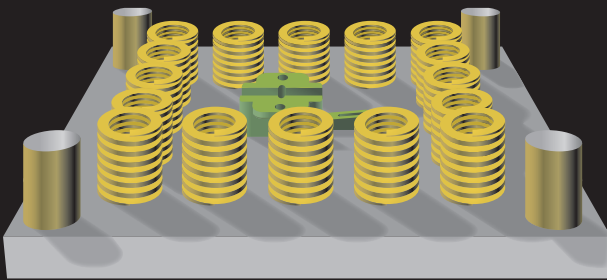

Wire springs (low power)
Ressorts de compression en fil (faible puissance)

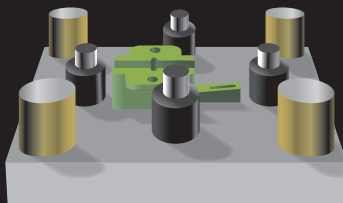

Gas springs (high power)
Ressorts à gaz (haute puissance)

Nitrogen gas springs offer many advantages over traditional wire springs: higher force, more compact dimensions (height and diameter), no pre-compression (pre-load) needed, no damage to the tool because of breakage, longer potential service life.

Reduction of die size translates into cost reduction and higher productivity, with advantages for both the die-maker and the die-user.

Les ressorts à gaz à l'azote offrent de nombreux avantages par rapport aux ressorts à fil traditionnels : force plus élevée, dimensions plus compactes (hauteur et diamètre), pas de pré-compression (précharge) nécessaire, pas d'endommagement de l'outil en raison de la casse, durée de vie potentielle plus longue.

La réduction de la taille des matrices se traduit par une réduction des coûts et une productivité accrue, avec des avantages à la fois pour le fabricant et l'utilisateur de matrices.



Durability, reliability, cost reduction

Durabilité, fiabilité, réduction des coûts

The Bordignon "Automotive Line" nitrogen gas springs have been developed as a reliable, standard solution for the automotive industry. Part of their design and technology comes from the well-known Bordignon "High Performance Line" nitrogen gas springs and therefore they offer – at an advantageous price – superior performance and durability when compared to the other nitrogen gas springs on the market.

Die makers will appreciate the Bordignon "Automotive Line" nitrogen gas springs as a standard solution for the automotive industry (as well as for other fields/applications) and will be confident in a superior product reliability. Die users will appreciate the Bordignon "Automotive Line" nitrogen gas springs for their superior durability, which translates into the reduction of production stops and costs.

The following graph shows a relative comparison between the service life of two Bordignon "Automotive Line" nitrogen gas springs series (AGS and TGS, taken as samples for all the other series) and the service life of the other four most durable nitrogen gas springs on the market (according to the tests performed by Bordignon*). The data have been collected from tests that were performed in several, different use conditions. In all these comparison tests, the Bordignon gas spring and the corresponding "non-Bordignon" model have always been tested in the same identical use conditions: the result is that, under the same use conditions, the service life of Bordignon nitrogen gas springs is from 1.2 up to 5 times longer than the service life of the other gas springs*.

Les ressorts à gaz azotés « Automotive Line » de Bordignon ont été développés comme une solution standard fiable pour l'industrie automobile. Une partie de leur conception et de leur technologie provient des célèbres ressorts à gaz azotés « High Performance Line » de Bordignon, et ils offrent donc – à un prix avantageux – des performances et une durabilité supérieures par rapport aux autres ressorts à gaz azotés sur le marché. Les fabricants de matrices apprécieront les ressorts à gaz azotés Bordignon « Automotive Line » en tant que solution standard pour l'industrie automobile (ainsi que pour d'autres domaines/applications) et seront confiants dans une fiabilité supérieure du produit. Les utilisateurs de matrices apprécieront les ressorts à gaz azotés Bordignon « Automotive Line » pour leur durabilité supérieure, ce qui se traduit par une réduction des arrêts de production et des coûts.

Le graphique suivant montre une comparaison relative entre la durée de vie de deux séries de ressorts à gaz azotés « Automotive Line » de Bordignon (AGS et TGS, prélevés comme échantillons pour toutes les autres séries) et la durée de vie des quatre autres ressorts à gaz azotés les plus durables du marché (selon les tests effectués par Bordignon*). Les données ont été recueillies à partir d'essais effectués dans plusieurs conditions d'utilisation différentes. Dans tous ces tests comparatifs, le ressort à gaz Bordignon et le modèle « non-Bordignon » correspondant ont toujours été testés dans les mêmes conditions d'utilisation identiques : le résultat est que, dans les mêmes conditions d'utilisation, la durée de vie des ressorts à gaz azotés Bordignon est de 1,2 à 5 fois plus longue que la durée de vie des autres ressorts à gaz*.

DURABILITY UNDER THE SAME OPERATING CONDITIONS * / DURABILITÉ DANS LES MÊMES CONDITIONS DE FONCTIONNEMENT *

(The graph shows reference values / Le graphique montre les valeurs de référence)

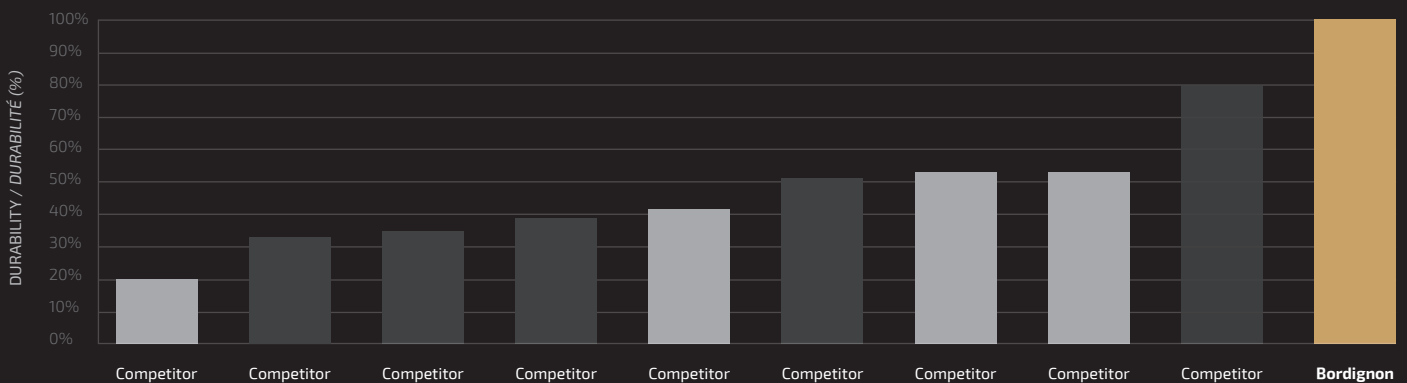

* The results of the tests performed by Bordignon are freely available on request
 * Les résultats des tests effectués par Bordignon sont disponibles gratuitement sur demande

■ Tests vs. Bordignon AGS
 ■ Tests vs. Bordignon TGS

Safety & reliability

Sécurité et fiabilité

Safety

Bordignon nitrogen gas springs have always been built with single ("monolithic") thick mechanical components, in order to ensure product integrity and maximum user's safety even under the most extreme wrong use conditions (collisions, etc.).

Bordignon construction - Single "monolithic" components
Construction de Bordignon - Composants uniques « monolithiques »

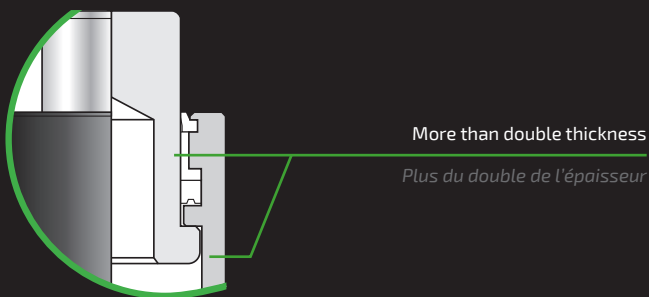

Bordignon gas spring components are coupled through thread connections, for the highest possible safety. Thread connections are standard in high pressure equipment around the world, such as waterjet cutting nozzles and ultra high pressure vessels (~10000 bar).

Bordignon construction - Body/bottom cap threaded junction
Construction de Bordignon - Jonction filetée corps/capuchon inférieur

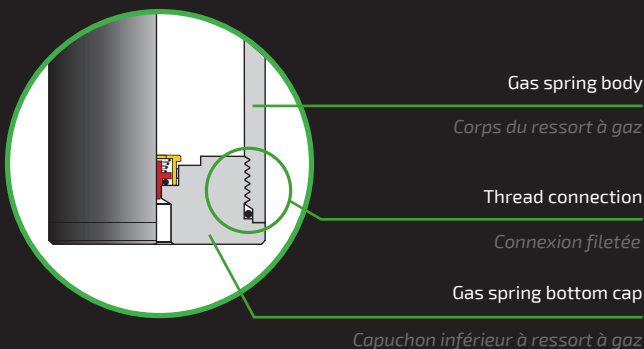

Sécurité

Les ressorts à gaz azotés Bordignon ont toujours été construits avec des composants mécaniques d'une seule épaisseur (« monolithiques »), afin d'assurer l'intégrité du produit et une sécurité maximale de l'utilisateur, même dans les conditions d'utilisation les plus extrêmes (collisions, etc.).

Other constructions - Several assembled components
Autres constructions - Plusieurs composants assemblés

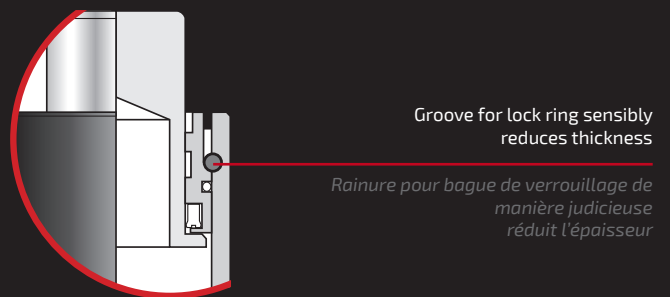

Les composants des ressorts à gaz Bordignon sont reliés par des connexions filetées, pour une sécurité maximale. Les connexions filetées sont standard dans les équipements à haute pression dans le monde entier, comme les buses de découpe à jet d'eau et les récipients à ultra haute pression (~10000 bar).

Other constructions - Body/bottom cap junction with lock ring
Autres constructions - Jonction corps/capuchon inférieur avec bague de verrouillage

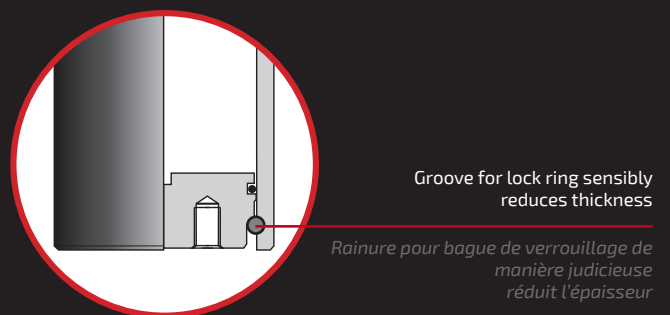

Reliability

All Bordignon nitrogen gas springs are self-lubricated, for millions of cycles, thanks to a solid lubricant.

Fiabilité

Tous les ressorts à gaz azoté Bordignon sont autolubrifiants, pour des millions de cycles, grâce à un lubrifiant solide.

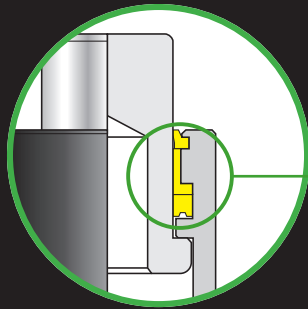

Self-lubricating sealing system

Système d'étanchéité autolubrifiant



FMEA & Safety protections

AMDEC et protections de sécurité



ISO 11901-5



VDI 3003 Part 1

FMEA - Failure Mode and Effect Analysis

In addition to the reliable design and construction, Bordignon nitrogen gas springs have always been built with safety systems (tested) which minimize the possible risks arising from non-proper use, even in extreme situations, thus ensuring the highest safety level for the end user. The safety protections of the Bordignon nitrogen gas springs are in accordance with the **ISO 11901-5** and **VDI 3003 Part 1** reference standards.

AMDEC - Analyse des Modes de Défaillance, de leurs Effets et de leur Criticité

En plus de la conception et de la construction fiables, les ressorts à gaz azotés Bordignon ont toujours été construits avec des systèmes de sécurité (testés) qui minimisent les risques possibles découlant d'une utilisation inappropriée, même dans des situations extrêmes, assurant ainsi le plus haut niveau de sécurité pour l'utilisateur final. Les protections de sécurité des ressorts à gaz azotés de Bordignon sont conformes aux normes de référence **ISO 11901-5** et **VDI 3003 Part 1**.

Uncontrolled return stroke safety protection (piston rod free release)

It is possible that the piston rod of the nitrogen gas spring does not immediately follow the return stroke of the press: this can be caused by a jammed tool part or cam. As a result, when the jammed part is released, the piston rod of the nitrogen gas spring exceeds the permitted speed during the return stroke and the piston rod slams unchecked onto the final stop (return stroke of the rod pushing out the jammed parts without stamping counterforce). In this case, Bordignon nitrogen gas springs are designed to vent the gas to the atmosphere – thereby depressurizing the gas spring – in the event that the maximum permitted piston rod speed is exceeded. This reduces the risks caused by the possible ejection of gas spring parts.

Protection de sécurité contre la course de retour incontrôlée (débrayage libre de la tige de piston)

Il est possible que la tige de piston du ressort à gaz d'azote ne suive pas immédiatement la course de retour de la presse : cela peut être causé par une pièce d'outil ou une came coincée. En conséquence, lorsque la pièce coincée est relâchée, la tige de piston du ressort à gaz d'azote dépasse la vitesse autorisée lors de la course de retour et la tige de piston claque sans contrôle sur la butée finale (course de retour de la tige poussant les pièces coincées sans contre-force d'emboutissage). Dans ce cas, les ressorts à gaz azotés Bordignon sont conçus pour évacuer le gaz dans l'atmosphère – dépressurisant ainsi le ressort à gaz – en cas de dépassement de la vitesse maximale autorisée de la tige de piston. Cela réduit les risques causés par l'éjection éventuelle des pièces du ressort à gaz.

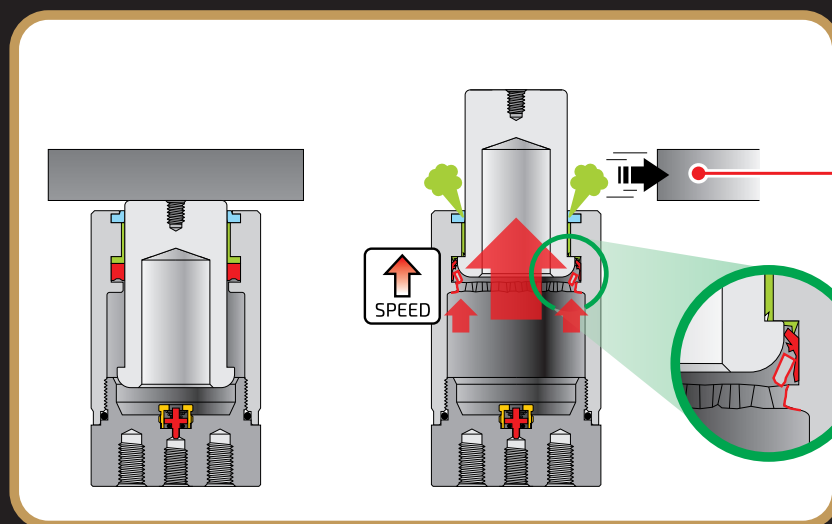

PISTON ROD FREE/UNCONTROLLED RELEASE (no press counterforce)

LIBÉRATION LIBRE/INCONTRÔLÉE DE LA TIGE DE PISTON (pas de contre-force de presse)

The piston rod mechanical stop (which is part of the gas spring body) is designed to break in case of excessive piston rod speed. The piston rod is safely retained inside the gas spring thanks to a secondary mechanical stop. This process damages the rod seal, so that the nitrogen gas leaks and the gas spring is discharged in complete safety.

La butée mécanique de la tige de piston (qui fait partie du corps du ressort à gaz) est conçue pour se casser en cas de vitesse excessive de la tige de piston. La tige de piston est maintenue en toute sécurité à l'intérieur du ressort à gaz grâce à une butée mécanique secondaire.

Ce processus endommage le joint de la tige, de sorte que l'azote gazeux s'échappe et que le ressort à gaz est déchargé en toute sécurité.

Overstroke safety protection

Overstroke occurs when the piston rod is pushed deeper into the gas spring body than nominal stroke. This could damage the gas spring. Bordignon nitrogen gas springs are designed to vent the nitrogen gas to the atmosphere in a controlled manner in the event of overstroke.

Protection de sécurité contre les surcours

Une course excessive se produit lorsque la tige de piston est enfoncée plus profondément dans le corps du ressort à gaz que la course nominale. Cela pourrait endommager le ressort à gaz. Les ressorts gazeux azotés Bordignon sont conçus pour évacuer l'azote gazeux dans l'atmosphère de manière contrôlée en cas de surcourse.

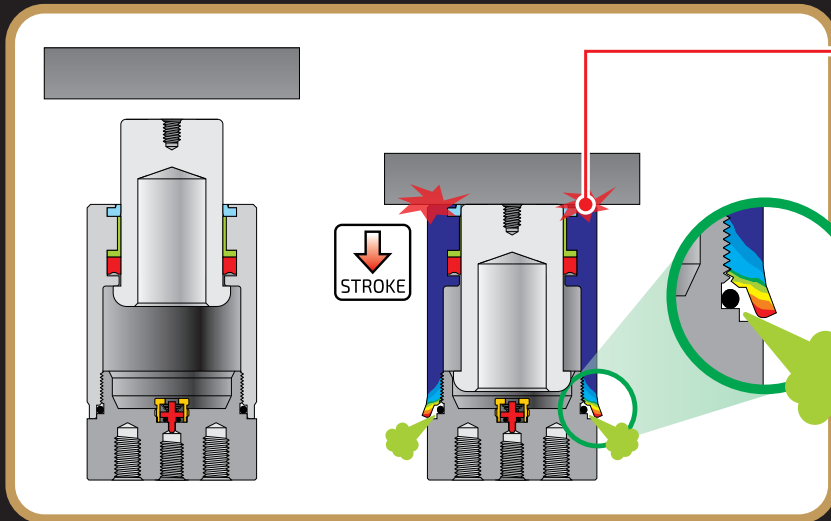

OVERSTROKE
(collision against the gas spring)

SURCOURSE
(collision contre le ressort à gaz)

The metal wall of the gas spring body is thinner at the bottom (where it retains the body/bottom cap junction sealing O-Ring), so that – in case of overstroke – it gets deformed first and allows a safe discharge of the gas spring, preventing the possible breakage of the gas spring body when still under pressure.

La paroi métallique du corps du ressort à gaz est plus mince en bas (où elle conserve le joint torique d'étanchéité de jonction corps/capuchon inférieur), de sorte qu'en cas de surcourse, il se déforme en premier et permet une décharge sûre du ressort à gaz, évitant ainsi la rupture éventuelle du corps du ressort à gaz lorsqu'il est encore sous pression.

Overpressure safety protection

If the pressure inside the gas spring rises above the permitted limit, due to fluid penetration or incorrect charging, there is the risk of gas spring breakage. Bordignon nitrogen gas springs are designed with an overpressure protection: when the overpressure protection system is triggered, the gas is vented to the atmosphere.

Protection de sécurité contre la surpression

Si la pression à l'intérieur du ressort à gaz dépasse la limite autorisée, en raison d'une pénétration de fluide ou d'une charge incorrecte, il existe un risque de rupture du ressort à gaz. Les ressorts à gaz azotés Bordignon sont conçus avec une protection contre les surpressions : lorsque le système de protection contre les surpressions est déclenché, le gaz est évacué dans l'atmosphère.

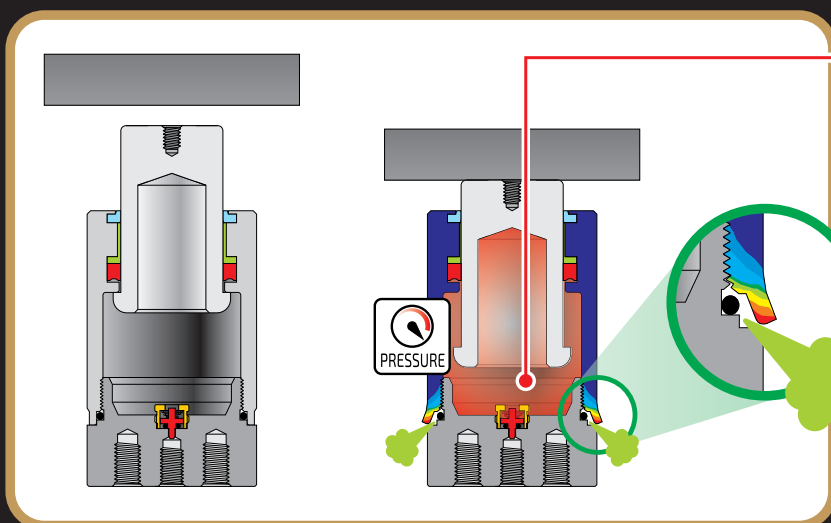

OVERPRESSURE
(excessive pressure inside the gas spring)

SURPRESSION
(pression excessive à l'intérieur du ressort à gaz)

The metal wall of the gas spring body is thinner at the bottom (where it retains the body/bottom cap junction sealing O-Ring), so that – in case of overpressure – it gets deformed first and allows a safe discharge of the gas spring, preventing the possible breakage of the gas spring body due to extreme pressure values.

NOTE: the body/bottom cap junction sealing O-Ring is always under gas pressure, even in normal operating conditions (the thread junction does not stop the gas flow).

La paroi métallique du corps du ressort à gaz est plus fine en bas (là où elle retient le joint torique d'étanchéité entre le corps et le bouchon inférieur), de sorte qu'en cas de surpression, elle se déforme en premier et permet une décharge sûre du ressort à gaz, évitant ainsi la rupture possible du corps du ressort à gaz sous des pressions extrêmes.
REMARQUE : le joint torique d'étanchéité entre le corps et le bouchon inférieur est toujours sous pression de gaz, même en fonctionnement normal (le filetage ne bloque pas l'écoulement du gaz).

Use instructions

Mode d'emploi

NO



The threaded hole on the piston rod is for transport and maintenance purposes only.
Do not use it for fastening the nitrogen gas spring.



*Le trou fileté sur la tige de piston est uniquement destiné au transport et à l'entretien.
Ne l'utilisez pas pour fixer le ressort à gaz azoté.*



No side forces. Work stroke always perpendicular to the base of the nitrogen gas spring.

Pas de forces latérales. Course de travail toujours perpendiculaire à la base du ressort à gaz azoté.



Avoid scratching and scoring on the piston rod.

Évitez de rayer et de rayer la tige de piston.



Do not make mechanical work on the nitrogen gas spring.

N'effectuez pas de travaux mécaniques sur le ressort à gaz azoté.



Do not disassemble the nitrogen gas spring. Maintenance only by authorized people. The authorization is given only after a class held by Bordignon.

Ne démontez pas le ressort à gaz à l'azote. Maintenance uniquement par des personnes autorisées. L'autorisation n'est donnée qu'à l'issue d'un cours tenu par Bordignon.



Max impact and max release speed: 1.6 m/s (1 m/s for TGS series). Maximum number of working cycles per minute: see product tables with the technical specifications.

Vitesse maximale d'impact et de déclenchement maximale: 1,6 m/s (1 m/s pour la série TGS). Nombre maximum de cycles de travail par minute: voir les tableaux des produits avec les spécifications techniques.



Do not freely release the piston rod. The piston rod goes up together with the press. If the screws used for the base-mounting are broken or deformed (stretched), find out the possible causes and eliminate them: there might have been free/uncontrolled releases of the piston rod.

Ne relâchez pas librement la tige de piston. La tige de piston monte en même temps que la presse. Si les vis utilisées pour le montage de la base sont cassées ou déformées (étirées), découvrez les causes possibles et éliminez-les: il se peut qu'il y ait eu des relâchements libres/incontrôlés de la tige de piston.



Protect against liquid or solid contaminants. The nitrogen gas springs are protected against contaminants by wiper ring. Do not use chemical products with low flash point (petrol, solvents, alcohol, etc.). Clean only with a dry cloth.

Protéger contre les contaminants liquides ou solides. Les ressorts à gaz azotés sont protégés contre les contaminants par un anneau racleur. N'utilisez pas de produits chimiques à faible point d'éclair (essence, solvants, alcool, etc.). Nettoyez uniquement avec un chiffon sec.

The products in this catalogue are designed for the use in press tools, dies and moulds. We can not take any responsibility for any not proper or different use.

Les produits de ce catalogue sont conçus pour être utilisés dans les outils de presse, les matrices et les moules. Nous ne pouvons prendre aucune responsabilité pour une utilisation inappropriée ou différente.

YES



Always fasten the nitrogen gas spring at the base to a flat and clean support surface with high resistance screws. Gas springs with more than one threaded hole at the base: the center hole is for charging/discharging only. Use all the other holes at the base for fixing. Fixing with flange: fasten the flange to a flat and clean support surface with high resistance screws. A safety plate must be present under the gas spring.



Fixez toujours le ressort à gaz d'azote à la base sur une surface d'appui plane et propre avec des vis à haute résistance. Ressorts à gaz avec plus d'un trou fileté à la base: le trou central sert uniquement à la charge/décharge. Utilisez tous les autres trous à la base pour la fixation. Fixation avec bride: fixez la bride sur une surface d'appui plane et propre à l'aide de vis à haute résistance. Une plaque de sécurité doit être présente sous le ressort à gaz.



Charge only with NITROGEN (N₂).

Chargez uniquement avec de l'AZOTE (N₂).



Hole for cylinder body Ø +1 mm. Draining hole for liquids.

Trou pour corps de cylindre Ø +1 mm. Trou de drainage pour les liquides.



Lubricate the piston rod with grease with molybdenum disulfide (MoS₂).

Lubrifiez la tige de piston avec de la graisse au disulfure de molybdène (MoS₂).



Operating temperature: MIN 0°C (32°F) - MAX 80°C (176°F). Do not heat.

Température de fonctionnement: MIN 0°C (32°F) - MAX 80°C (176°F). Ne pas chauffer.



Protect against solid contaminants with a metal bellow, liquid contaminants with a polymeric bellow. Fasten the protection bellow to the die plate.

Protégez-vous contre les contaminants solides avec un soufflet métallique, les contaminants liquides avec un soufflet polymère. Fixez le soufflet de protection à la plaque de matrice.



When using nitrogen gas springs in a LINKED SYSTEM, make sure to request/order the gas springs "discharged, without valve" ("L-version"). Otherwise, to adapt a self-contained gas spring for a linked system, BEFORE installing any fittings and hoses: remove the side cap using a flat-end allen key (hexagonal key); discharge the gas spring completely using the proper ADS discharging device; remove the valve cartridge using a flat-end 3 mm allen key (hexagonal key).

Lors de l'utilisation de ressorts à gaz à l'azote dans un SYSTÈME LIÉ, assurez-vous de demander/commander les ressorts à gaz « déchargés, sans soupape » (« version L »). Sinon, pour adapter un ressort à gaz autonome à un système lié, AVANT d'installer tous les raccords et tuyaux: retirez le capuchon latéral à l'aide d'une clé Allen à extrémité plate (clé hexagonale); déchargez complètement le ressort à gaz à l'aide du dispositif de décharge ADS approprié; retirez la cartouche de valve à l'aide d'une clé Allen à extrémité plate de 3 mm (clé hexagonale).



IMPORTANT: periodically check for use instructions updates on our website. For possible additional use instructions not explicitly specified here, refer to the ISO 11901-5 standard. Pass the nitrogen gas springs use instructions to the end-user of the product.

IMPORTANT: vérifiez périodiquement les mises à jour des instructions d'utilisation sur notre site Web. Pour d'éventuelles instructions d'utilisation supplémentaires non explicitement spécifiées ici, reportez-vous à la norme ISO 11901-5. Transmettez les instructions d'utilisation des ressorts à gaz azoté à l'utilisateur final du produit.

Information

Information

- 100% usable stroke
- You might adjust the initial force with the charging and discharging set (model COMPL)
- Charging pressure: MIN 20 bar - MAX see table on catalogue
- Initial force increases by ~0.34% per each 1°C increase from the reference temperature of 20°C (room temperature, do not heat)
- How to calculate the charging pressure (bar) for initial forces (daN) lower than MAX initial force on catalogue:

$$P_u = \frac{F_u \times P_{in}}{F_{in}}$$

P_u = pressure to be calculated (bar)
 P_{in} = MAX pressure on catalogue (bar)
 F_u = initial force (daN) for which you wish to determine the pressure
 F_{in} = MAX initial force on catalogue (daN)

- How to calculate the force (daN) at intermediate strokes:

$$F_{inter} = F_{in} + \frac{S_u}{S} \times (F_{fin} - F_{in})$$

F_{inter} = intermediate force to be calculated (daN)
 F_{in} = MAX initial force on catalogue (daN)
 F_{fin} = MAX final force on catalogue (daN)
 S_u = stroke (mm) for which you wish to calculate the force
 S = MAX stroke on catalogue (mm)

- Please note: the final forces (forces at full stroke) indicated in the catalogue are reference values measured in static conditions. The actual final forces generated under use conditions may vary, since they depend on the specific parameters of the application, such as the working speed (cycles per minute).

- Course 100% utilisable
- Vous pouvez ajuster la force initiale avec le kit de charge et de décharge (modèle COMPL)
- Pression de suralimentation : MIN 20 bar - MAX voir tableau sur catalogue
- La force initiale augmente de ~0,34 % pour chaque augmentation de 1 °C par rapport à la température de référence de 20 °C (température ambiante, ne pas chauffer)
- Comment calculer la pression de charge (bar) pour des forces initiales (daN) inférieures à la force initiale MAX sur catalogue:

$$P_u = \frac{F_u \times P_{in}}{F_{in}}$$

P_u = pression à calculer (bar)
 P_{in} = Pression MAX sur catalogue (bar)
 F_u = force initiale (daN) pour laquelle vous souhaitez déterminer la pression
 F_{in} = Force initiale MAX sur catalogue (daN)

- Comment calculer la force (daN) à des courses intermédiaires :

$$F_{inter} = F_{in} + \frac{S_u}{S} \times (F_{fin} - F_{in})$$

F_{inter} = force intermédiaire à calculer (daN)
 F_{in} = Force initiale MAX sur catalogue (daN)
 F_{fin} = Force finale MAX sur catalogue (daN)
 S_u = course (mm) pour laquelle vous souhaitez calculer la force
 S = Course MAX sur catalogue (mm)

- Attention : les forces finales (forces à pleine course) indiquées dans le catalogue sont des valeurs de référence mesurées dans des conditions statiques. Les forces finales réelles générées dans les conditions d'utilisation peuvent varier, car elles dépendent des paramètres spécifiques de l'application, tels que la vitesse de travail (cycles par minute).

Catalogue Help

Aide du catalogue

How to order (Gas Springs)

You order (example): **No. 8 AGS1000-25-A**

You receive: 8 pieces AGS series nitrogen gas springs, ready for use, diameter Ø 50 mm, stroke 25 mm, initial force 920 daN (other specifications on the AGS series pages).

The new codes/revisions will be supplied once the old ones are out of stock.

For items standardized by automotive manufacturers, orders must be placed directly using the OEM part numbers.

Comment commander (Ressorts à gaz)

Vous commandez (exemple): **N° 8 pièces AGS1000-25-A**

Vous recevez : 8 pièces de ressorts à gaz d'azote de la série AGS, prêts à l'emploi, diamètre Ø 50 mm, course 25 mm, force initiale 920 daN (autres spécifications sur les pages de la série AGS).

Les nouveaux codes/révisions seront fournis une fois que les anciens seront en rupture de stock.

Pour les articles normalisés par les constructeurs automobiles, les commandes doivent être passées directement en utilisant les numéros de pièce OEM

Gas Spring Accessories

Accessories for fixing, charging/discharging, linking to open system, etc. can be found in this catalogue further on. ATTENTION: use Bordignon nitrogen gas springs with Bordignon accessories only.

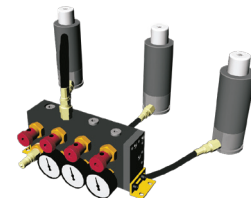
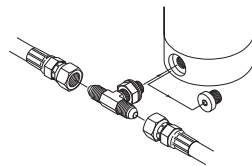
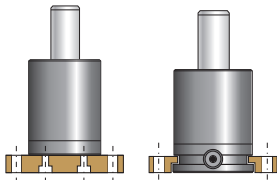

Accessoires pour ressorts à gaz

Vous trouverez plus loin dans ce catalogue les accessoires pour la fixation, la charge/décharge, la liaison au système ouvert, etc. ATTENTION : utilisez uniquement les ressorts à gaz azotés Bordignon avec les accessoires Bordignon.

Comment commander (Accessoires)

Vous commandez (exemple): **N° 1 pièce AP01**

Vous recevez : 1 panneau de commande AP01 (voir les spécifications techniques sur la page dédiée plus loin).

How to order (Accessories)

You order (example): **No. 1 AP01**

You receive: 1 piece AP01 control panel (see technical specifications on the dedicated page further on).



AP01

2D & 3D Technical drawings

Download various 2D & 3D file formats from www.bordignon.com

Dessins techniques 2D et 3D

Téléchargez divers formats de fichiers 2D et 3D à partir de www.bordignon.com

Nitrogen gas springs

for press tools, dies and moulds

Ressorts à gaz pour outils de presse, matrices et moules



- One series of nitrogen gas ejectors in accordance to the VDI 3004 standard: EGS series
- Four series of nitrogen gas springs in accordance to the ISO 11901 and VDI 3003 standards: VGS (small diameters, standard forces), AGS (compact-height, high force), IGS (standard dimensions, standard force), PGS (standard dimensions, high force)
- One series of ultra-high power, compact-diameter nitrogen gas springs: TGS series
- Several other gas spring series for an enhanced use versatility
- Accessories for fixing (base plates, half-flanges, collar flanges, foot brackets, front supports)
- Accessories for linked system (hoses, fittings, control panels, pressure switches, safety valves, distribution blocks)
- Accessories for charging and discharging (charging and discharging set, charging adapters, discharging devices, Booster)
- One series of OV nitrogen gas springs for "OV system" (alternative manifold system): AGS -OV (and related accessories)
- Other accessories (hose crimping device, counter plates, identifying plates, lubrication grease, initial force gauge)

- *Une série d'éjecteurs à gaz d'azote conforme à la norme VDI 3004 : série EGS*
- *Quatre séries de ressorts à gaz conformes aux normes ISO 11901 et VDI 3003 : VGS (petits diamètres, forces standard), AGS (hauteur compacte, force élevée), IGS (dimensions standard, force standard), PGS (dimensions standard, force élevée)*
- *Une série de ressorts à gaz ultra-puissants et de diamètre compact : série TGS*
- *Plusieurs autres séries de ressorts à gaz pour une polyvalence d'utilisation accrue*
- *Accessoires de fixation (plaques de base, demi-bridés, brides de collier, supports de pied, supports avant)*
- *Accessoires pour système relié (tuyaux, raccords, panneaux de commande, pressostats, soupapes de sécurité, blocs de distribution)*
- *Accessoires pour la charge et la décharge (kit de charge et de décharge, adaptateurs de charge, dispositifs de décharge, Booster)*
- *Une série de ressorts à gaz à l'azote OV pour « système OV » (système de collecteur alternatif) : AGS-OV (et accessoires associés)*
- *Autres accessoires (dispositif de sertissage de tuyaux, contre-plaques, plaques d'identification, graisse lubrifiante, appareil de mesure de force initiale)*

Ford	W-DX35-60M
VW	39D 549

nitrogen gas ejectors / éjecteur à gaz d'azote

EGS series nitrogen gas ejectors feature compact length and several standard forces to choose from. EGS series nitrogen gas ejectors are self-lubricated.

Les éjecteurs à gaz d'azote de la série EGS se caractérisent par une longueur compacte et plusieurs forces standard au choix. Les éjecteurs d'azote gazeux de la série EGS sont autolubrifiés.

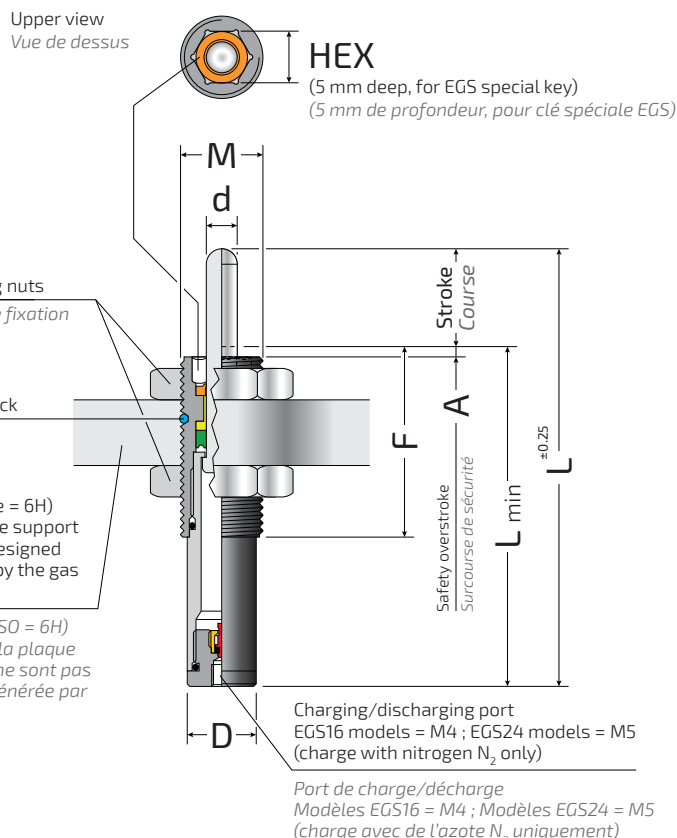

An internal thread M (ISO tolerance = 6H) must be properly machined into the support plate (the fastening nuts are not designed for sustaining the load generated by the gas ejector)

Un filetage intérieur M (tolérance ISO = 6H) doit être correctement usiné dans la plaque de support (les écrous de fixation ne sont pas conçus pour supporter la charge générée par l'éjecteur à gaz)

Technical notes / Notes techniques
Important use instructions in the dedicated catalogue section.
Instructions d'utilisation importantes dans la section dédiée au catalogue.

Fixing possibilities / Possibilités de fixation

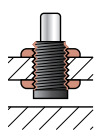

threaded hole on the die plate
trou fileté sur la plaque de matrice

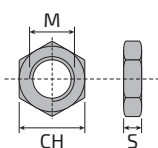
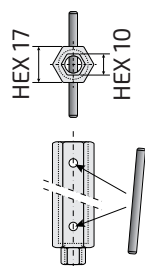

ACCESSORIES FOR INSTALLATION / ACCESSOIRES POUR L'INSTALLATION

	Model Modèle
Special key for installation Clé spéciale pour l'installation	EGS-CH

Model Modèle	Description Description	M	S mm	CH mm
EG-D-16	Fastening nut Écrou de fixation	M16 x 1.5	8	24
EG-D-16-2		M16 x 2	8	24
EG-D-24		M24 x 1.5	10	36

SAFETY PROTECTIONS / PROTECTIONS DE SÉCURITÉ









UNCONTROLLED
RETURN SPEED /
VITESSE DE RETOUR
INCONTRÔLÉE

























OVERSTROKE /
SURCOURSE



OVERPRESSURE /
SURPRESSION

Model Modèle	MAX Stroke 100% usable MAX course 100% utilisable		L min mm	L mm	M mm	F mm	A mm	d mm	D mm	HEX mm	 bar (MPa)	 daN	 daN	Cycles per minute MAX Cycles par minute MAX	Gas volume Gaz volume dm ³	Weight Poids kg
	mm	mm														
EGS16x1.5-10-...	10	55	65	M16 x 1.5	35	1	6	13.5	10	See table below Voir le tableau ci-dessous	 x	1.51	300	0.001	0.05	
	20-...	20	65									85	1.60	150	0.002	0.06
	30-...	30	75									105	1.63	100	0.003	0.07
	40-...	40	85									125	1.65	75	0.003	0.07
	50-...	50	95									145	1.66	60	0.004	0.08
	60-...	60	105									165	1.67	50	0.005	0.08
	70-...	70	115									185	1.68	45	0.006	0.09
	80-...	80	125									205	1.68	40	0.007	0.10
	100-...	100	145									245	1.69	30	0.008	0.11
	125-...	125	170									295	1.70	25	0.010	0.12
EGS16x2-10-...	10	55	65	M16 x 2	35	1	6	13.5	10	See table below Voir le tableau ci-dessous	 x	1.51	300	0.001	0.05	
	20-...	20	65									85	1.60	150	0.002	0.06
	30-...	30	75									105	1.63	100	0.003	0.07
	40-...	40	85									125	1.65	75	0.003	0.07
	50-...	50	95									145	1.66	60	0.004	0.08
	60-...	60	105									165	1.67	50	0.005	0.08
	70-...	70	115									185	1.68	45	0.006	0.09
	80-...	80	125									205	1.68	40	0.007	0.10
	100-...	100	145									245	1.69	30	0.008	0.11
	125-...	125	170									295	1.70	25	0.010	0.12
EGS24x1.5-10-...	10	55	65	M24 x 1.5	35	1	12	21.5	17	See table below Voir le tableau ci-dessous	 x	1.74	300	0.003	0.16	
	20-...	20	65									85	1.85	150	0.006	0.18
	30-...	30	75									105	1.89	100	0.008	0.20
	40-...	40	85									125	1.92	75	0.011	0.23
	50-...	50	95									145	1.93	60	0.013	0.25
	60-...	60	105									165	1.94	50	0.016	0.27
	70-...	70	115									185	1.95	45	0.018	0.29
	80-...	80	125									205	1.96	40	0.021	0.30
	100-...	100	145									245	1.97	30	0.026	0.33
	125-...	125	170									295	1.97	25	0.032	0.35

All the gas ejector models in this table are in accordance with Article 4.3 of the 2014/68/EU Pressure Equipment Directive (PED)
Tous les modèles d'éjecteurs à gaz de ce tableau sont conformes à l'article 4.3 de la directive 2014/68/UE sur les équipements sous pression (PED)

Basic code Code de base	Force code Code de force	 bar (MPa)	 daN	 daN	Label color Couleur de l'étiquette	How to order Comment commander
EGS16x1.5-...	4	12 (1.2)	4	See table above Voir le tableau ci-dessus		Purple / Violet
	6	20 (2.0)	6			Green / Vert
	11	40 (4.0)	11			Blue / Bleu
	21	75 (7.5)	21			Red / Rouge
	42	150 (15.0)	42			Yellow / Jaune
	0	0	0			Black / Noir
(other / autre)	10 (1.0)-150 (15.0)	3-42			Black / Noir	
EGS16x2-...	4	12 (1.2)	4	See table above Voir le tableau ci-dessus		Purple / Violet
	6	20 (2.0)	6			Green / Vert
	11	40 (4.0)	11			Blue / Bleu
	21	75 (7.5)	21			Red / Rouge
	42	150 (15.0)	42			Yellow / Jaune
	0	0	0			Black / Noir
(other / autre)	10 (1.0)-150 (15.0)	3-42			Black / Noir	
EGS24x1.5-...	23	20 (2.0)	23	See table above Voir le tableau ci-dessus		Green / Vert
	45	40 (4.0)	45			Blue / Bleu
	85	75 (7.5)	85			Red / Rouge
	170	150 (15.0)	170			Yellow / Jaune
	0	0	0			Black / Noir
	(other / autre)	10 (1.0)-150 (15.0)	11-170			

ALL EGS MODELS ARE DISPOSABLE (REPAIR KIT NOT AVAILABLE) /
TOUS LES MODÈLES EGS SONT JETABLES (KIT DE RÉPARATION NON DISPONIBLE)

FORCE RISE VS. USED STROKE LENGTH CHARTS

GRAP. AUGM. DE LA FORCE VS. COURSE UTILISÉE

The force curves in the charts below are obtained from reference values measured in static conditions. The actual forces generated under use conditions may vary, since they depend on the specific parameters of the application, such as the working speed (cycles per minute).

Les courbes de force dans les tableaux ci-dessous sont obtenues à partir de valeurs de référence mesurées dans des conditions statiques. Les forces réelles générées dans les conditions d'utilisation peuvent varier, car elles dépendent des paramètres spécifiques de l'application, tels que la vitesse de travail (cycles par minute).

**EGS16x1.5
EGS16x2**

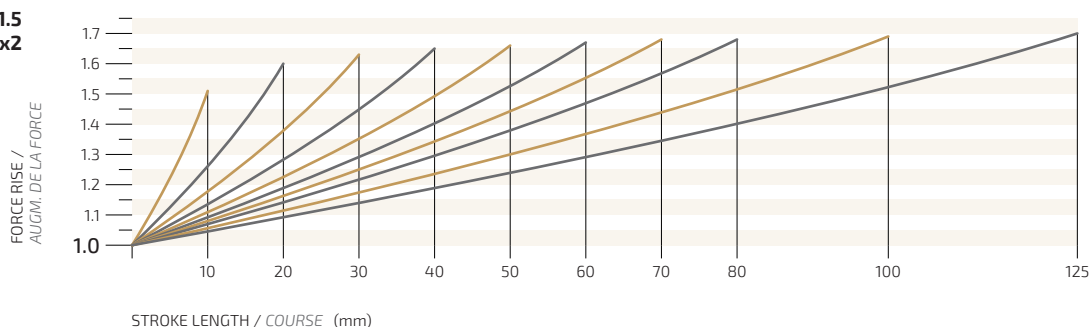

EGS24x1.5

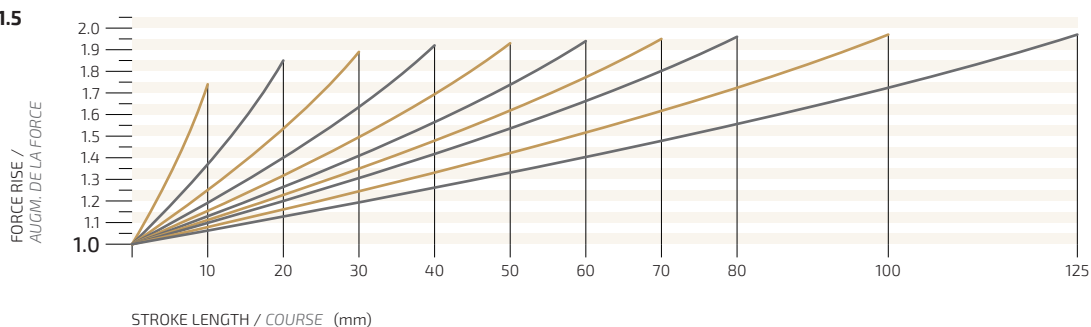

VGS



ISO 11901-1 VDI 3003 Part 2

This gas spring series includes the models compliant with automotive standards / La série de ressorts à gaz comprend les modèles conformes aux normes autos

BMW	B2 4007	PSA	E24.54.815.G
FCA	075.90.50	Renault	EM24.54.700
MB	B8 3180 220 000 002	VW	39D 878
Nissan	K32H2		

50~200



VGS series nitrogen gas springs feature standard dimensions for small diameters. With the VGS series nitrogen gas springs, Bordignon now ensures a great interchangeability and a superior reliability. VGS series nitrogen gas springs are self-lubricated.

Les ressorts à gaz de la série VGS présentent des dimensions standard pour les petits diamètres. Avec les ressorts à gaz de la série VGS, Bordignon assure désormais une grande interchangeabilité et une fiabilité supérieure. Les ressorts à gaz de la série VGS sont autolubrifiants.

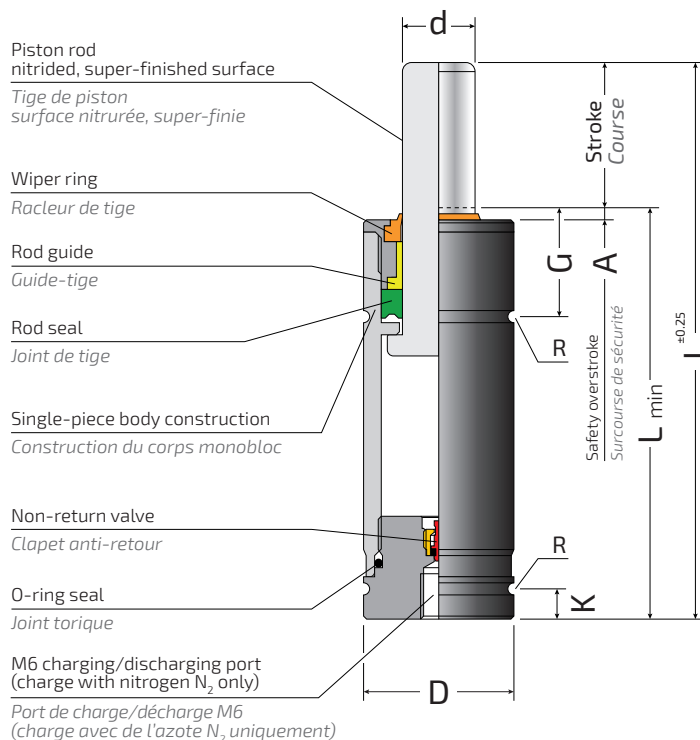

Technical notes / Notes techniques
 Important use instructions in the dedicated catalogue section.
 Instructions d'utilisation importantes dans la section dédiée au catalogue.

Fixing possibilities / Possibilités de fixation

GAS SPRING BASE / BASE DU RESSORT À GAZ

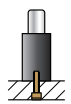

at the base with screw
 à la base avec vis

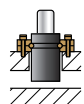

with collar flange
 avec bride de collier
FL

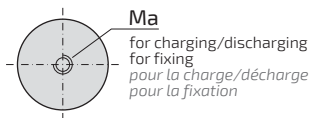

VGS50, VGS70, VGS90, VGS200

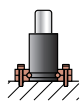

with collar flange (base)
 avec bride de collier (base)
FV, FL

SAFETY PROTECTIONS / PROTECTIONS DE SÉCURITÉ









UNCONTROLLED RETURN SPEED / VITESSE DE RETOUR INCONTRÔLÉE





























OVERSTROKE / SURCOURSE



OVERPRESSURE / SURPRESSION

Model Modèle	MAX Stroke 100% usable MAX course 100% utilisable		Lmin mm	L mm	D mm	d mm	G mm	A mm	R mm	K mm	Ma	 bar (MPa)	 daN	 daN	Cycles per minute MAX Cycles par minute MAX	Gas volume Gaz volume dm ³	Weight Poids kg	
	Lmin mm	L mm																
VGS50-07-...	7	49	56												1.50	300	0.001	0.03
10-...	10	52	62												1.50	300	0.001	0.03
13-...	12.7	54.7	67.4												1.60	235	0.001	0.03
15-...	15	57	72												1.60	200	0.001	0.03
19-...	19	61	80												1.70	160	0.002	0.03
25-...	25	67	92												1.70	120	0.002	0.03
38-...	38	80	118	12 +0.1	6	17	1	0.8	-	M6 x 6	See table below Voir le tableau ci-dessous		x	1.80	80	0.003	0.04	
50-...	50	92	142												1.80	60	0.004	0.05
63-...	63.5	108.5	172												1.80	50	0.005	0.06
75-...	75	120	195												1.80	40	0.005	0.06
80-...	80	125	205												1.80	40	0.006	0.07
100-...	100	145	245												1.90	30	0.007	0.08
125-...	125	170	295												1.90	25	0.008	0.09
VGS70-07-...	7	49	56												1.43	300	0.001	0.04
10-...	10	52	62												1.50	300	0.001	0.05
13-...	12.7	54.7	67.4												1.50	235	0.002	0.05
15-...	15	57	72												1.57	200	0.002	0.05
19-...	19	61	80												1.57	160	0.002	0.05
25-...	25	67	92												1.64	120	0.003	0.06
38-...	38.1	80.1	118.2	15 +0.1	7	17	1	0.8	-	M6 x 6	See table below Voir le tableau ci-dessous		x	1.71	80	0.004	0.07	
50-...	50	92	142												1.71	60	0.005	0.08
63-...	63.5	108.5	172												1.71	50	0.007	0.09
75-...	75	120	195												1.71	40	0.008	0.10
80-...	80	125	205												1.71	40	0.008	0.10
100-...	100	145	245												1.79	30	0.010	0.12
125-...	125	170	295												1.79	25	0.013	0.14
VGS90-07-...	7	49	56												1.39	300	0.002	0.07
10-...	10	52	62												1.39	300	0.002	0.07
13-...	12.7	54.7	67.4												1.44	235	0.003	0.08
15-...	15	57	72												1.44	200	0.003	0.08
25-...	25	67	92												1.50	120	0.005	0.09
38-...	38.1	80.1	118.2	19 +0/-0.3	8	17	1	1	6	M6 x 8	See table below Voir le tableau ci-dessous		x	1.50	80	0.007	0.11	
50-...	50	92	142												1.50	60	0.009	0.12
63-...	63.5	108.5	172												1.50	50	0.012	0.14
80-...	80	125	205												1.50	40	0.015	0.15
100-...	100	145	245												1.50	30	0.019	0.17
125-...	125	170	295												1.50	25	0.023	0.20
VGS200-07-...	7	49	56												1.43	300	0.004	0.12
10-...	10	52	62												1.48	300	0.005	0.13
13-...	12.7	54.7	67.4												1.50	235	0.006	0.13
15-...	15	57	72												1.53	200	0.006	0.14
16-...	16	58	74												1.53	190	0.007	0.14
25-...	25	67	92	25 +0/-0.3	12	17	1	1	5	M6 x 9	See table below Voir le tableau ci-dessous		x	1.55	120	0.010	0.16	
38-...	38.1	80.1	118.2												1.60	80	0.014	0.19
50-...	50	92	142												1.60	60	0.018	0.20
63-...	63.5	108.5	172												1.60	50	0.024	0.23
80-...	80	125	205												1.60	40	0.029	0.26
100-...	100	145	245												1.60	30	0.036	0.30
125-...	125	170	295												1.63	25	0.044	0.34

All the gas spring models in this table are in accordance with Article 4.3 of the 2014/68/EU Pressure Equipment Directive (PED)
Tous les modèles de ressorts à gaz de ce tableau sont conformes à l'article 4.3 de la directive 2014/68/UE sur les équipements sous pression (PED)

Basic code Code de base	Force code Code de force	 bar (MPa)	 daN	 daN	Label color Couleur de l'étiquette	How to order Comment commander
VGS50-...	13	45 (4.5)	13	See table above Voir le tableau ci-dessous	 Green / Vert	VGS90-50-90 VGS nitrogen gas spring with 19 mm body diameter, 50 mm maximum available stroke length, 90 daN initial force (180 bar / 18.0 MPa charging pressure), yellow label. Ressort à gaz à l'azote VGS avec un diamètre de corps de 19 mm, longueur de course maximale disponible de 50 mm, force initiale de 90 daN (180 bar / 18.0 MPa de pression de charge), étiquette jaune.
	25	90 (9.0)	25		 Blue / Bleu	
	38	135 (13.5)	38		 Red / Rouge	
	50	180 (18.0)	50		 Yellow / Jaune	
	0	0	0		 Black / Noir	
(other / autre)		20 (2.0)-180 (18.0)	6-50		 Black / Noir	
VGS70-...	18	45 (4.5)	18	See table above Voir le tableau ci-dessous	 Green / Vert	
	35	90 (9.0)	35		 Blue / Bleu	
	50	135 (13.5)	50		 Red / Rouge	
	70	180 (18.0)	70		 Yellow / Jaune	
	0	0	0		 Black / Noir	
(other / autre)		20 (2.0)-180 (18.0)	8-70		 Black / Noir	
VGS90-...	5	10 (1.0)	5	See table above Voir le tableau ci-dessous	 Orange / Orange	
	10	20 (2.0)	10		 Purple / Violet	
	30	60 (6.0)	30		 Green / Vert	
	50	100 (10.0)	50		 Blue / Bleu	
	70	140 (14.0)	70		 Red / Rouge	
(other / autre)		10 (1.0)-180 (18.0)	5-90		 Black / Noir	
VGS200-...	17	15 (1.5)	17	See table above Voir le tableau ci-dessous	 Orange / Orange	
	28	25 (2.5)	28		 Purple / Violet	
	50	45 (4.5)	50		 Green / Vert	
	100	90 (9.0)	100		 Blue / Bleu	
	150	135 (13.5)	150		 Red / Rouge	
(other / autre)		10 (1.0)-180 (18.0)	11-200		 Black / Noir	

REPAIR KIT / KIT DE RÉPARATION

Gas spring code Code des ressorts à gaz	Repair kit code Code du kit de réparation
VGS90-...	KR/VGS90
VGS200-...	KR/VGS200

VGS50-... AND VGS70-... MODELS ARE DISPOSABLE (REPAIR KIT NOT AVAILABLE) /
VGS50-... ET VGS70-... LES MODÈLES SONT JETABLES (KIT DE RÉPARATION NON DISPONIBLE)

Download repair instructions from www.bordignon.com /
Téléchargez les instructions de réparation de www.bordignon.com

FORCE RISE VS. USED STROKE LENGTH CHARTS

GRAP. AUGM. DE LA FORCE VS. COURSE UTILISÉE

The force curves in the charts below are obtained from reference values measured in static conditions. The actual forces generated under use conditions may vary, since they depend on the specific parameters of the application, such as the working speed (cycles per minute).

Les courbes de force dans les tableaux ci-dessous sont obtenues à partir de valeurs de référence mesurées dans des conditions statiques. Les forces réelles générées dans les conditions d'utilisation peuvent varier, car elles dépendent des paramètres spécifiques de l'application, tels que la vitesse de travail (cycles par minute).

VGS50

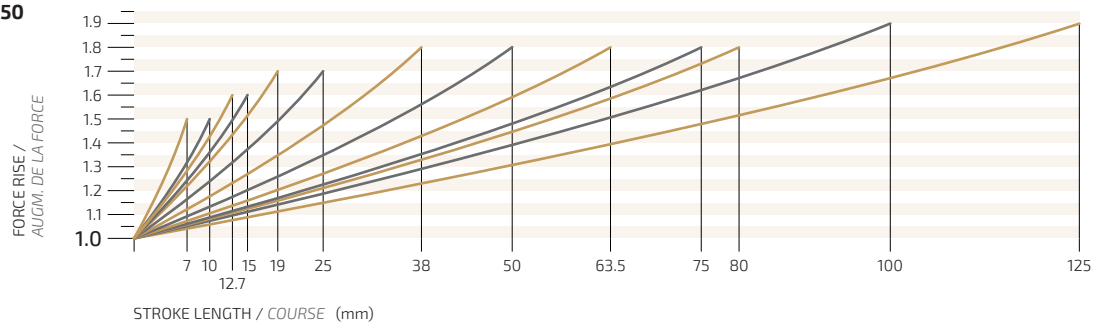

VGS70

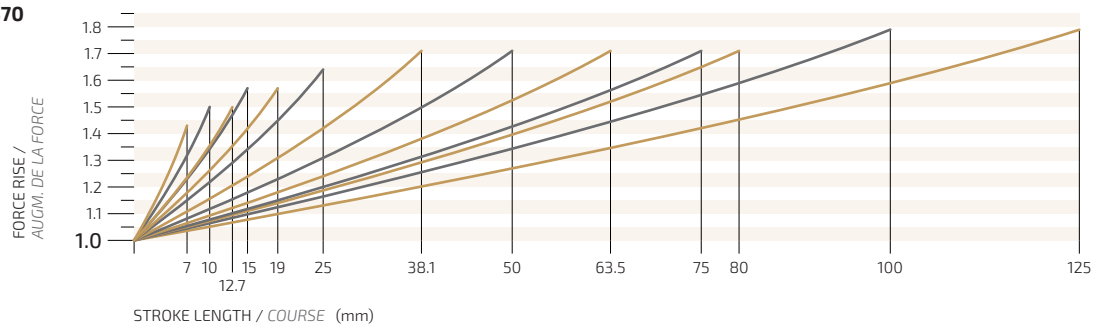

VGS90

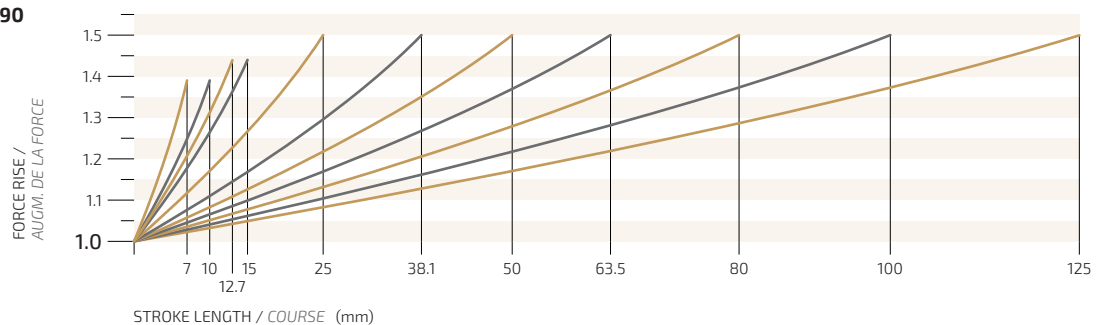

VGS200

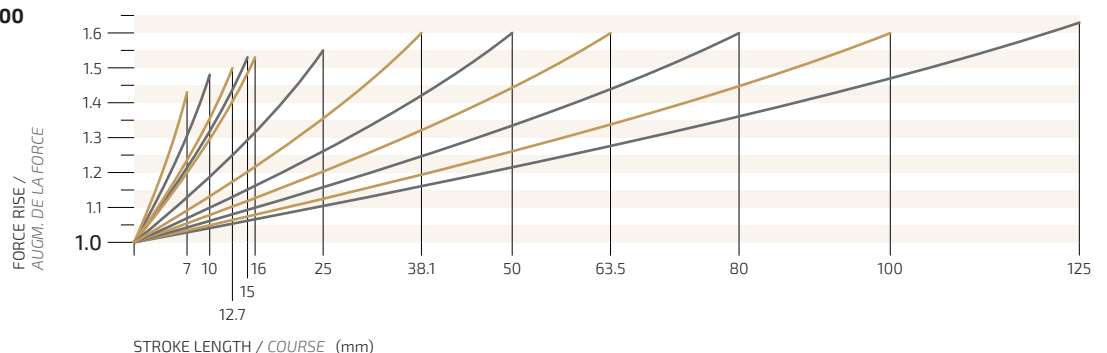

AGS



ISO 11901-3 VDI 3003 Part 3

This gas spring series includes the models compliant with automotive standards /
La série de ressorts à gaz comprend les modèles conformes aux normes autos

BMW	B2 4005	MB	B8 3180 220 000 004
FCA	075.90.60	VW	39D 997

170-320

COMPACT POWER

COMPACT HEIGHT



AGS series nitrogen gas springs are highly appreciated in the automotive industry thanks to the compact dimensions, the fixing and linking possibilities. With the AGS series nitrogen gas springs, Bordignon now ensures a great interchangeability and a superior reliability. AGS series nitrogen gas springs are self-lubricated.

Les ressorts à gaz de la série AGS sont très appréciés dans l'industrie automobile grâce à leurs dimensions compactes, aux possibilités de fixation et de liaison. Avec les ressorts à gaz de la série AGS, Bordignon assure désormais une grande interchangeabilité et une fiabilité supérieure. Les ressorts à gaz de la série AGS sont autolubrifiants.

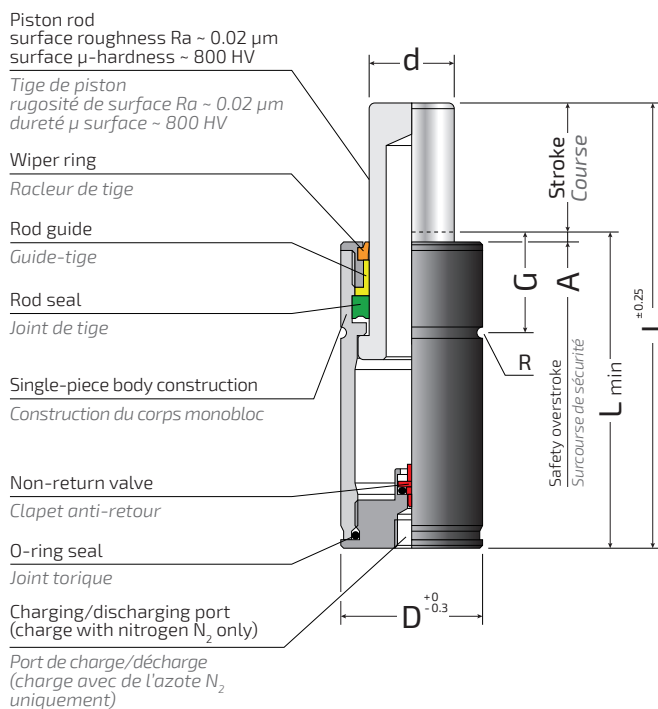

Technical notes / Notes techniques
Important use instructions in the dedicated catalogue section.
Instructions d'utilisation importantes dans la section dédiée au catalogue.

Fixing possibilities / Possibilités de fixation

GAS SPRING BASE / BASE DU RESSORT À GAZ

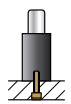

at the base with screw
à la base avec vis



with collar flange
avec bride de collier
FL

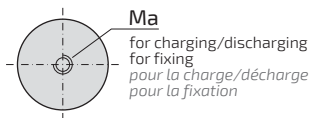

AGS170, AGS320

SAFETY PROTECTIONS / PROTECTIONS DE SÉCURITÉ



UNCONTROLLED RETURN SPEED /
VITESSE DE RETOUR INCONTRÔLÉE



OVERSTROKE /
SURCOURSE



OVERPRESSURE /
SURPRESSION

AGS 170-320

Model Modèle	MAX Stroke 100% usable MAX course 100% utilisable		D mm	d mm	G mm	A mm	R mm	Ma	bar (MPa)	daN	daN	Cycles per minute MAX Cycles par minute MAX	Gas volume Gaz volume dm ³	Weight Poids kg	
	Lmin mm	L mm													
AGS170-07-A	7	37	19	11	17	1	1	M6 x 5	180 (18.0)	170		290	300	0.002	0.06
10-A	10	40										295	300	0.003	0.06
13-A	13	43										300	230	0.003	0.07
15-A	15	45										310	200	0.004	0.07
19-A	19	49										320	160	0.005	0.08
25-A	25	55										330	120	0.006	0.08
32-A	32	62										340	90	0.007	0.09
38-A	38	68										340	80	0.009	0.10
50-A	50	80										350	60	0.011	0.12
63-A	63	93										355	50	0.014	0.14
75-A	75	110										360	40	0.017	0.16
80-A	80	115										360	40	0.018	0.16
100-A	100	135										360	30	0.023	0.19
125-A	125	160										360	25	0.028	0.23
AGS320-07-A	7	37										25	15	17	1
10-A	10	40	490	300	0.005	0.11									
13-A	13	43	550	230	0.006	0.12									
15-A	15	45	550	200	0.007	0.12									
19-A	19	49	580	160	0.008	0.13									
25-A	25	55	600	120	0.011	0.14									
32-A	32	62	630	90	0.013	0.16									
38-A	38	68	640	80	0.015	0.17									
50-A	50	80	640	60	0.020	0.20									
63-A	63	93	640	50	0.025	0.23									
75-A	75	110	640	40	0.031	0.26									
80-A	80	115	640	40	0.033	0.27									
100-A	100	135	650	30	0.040	0.32									
125-A	125	160	660	25	0.050	0.38									

All the gas spring models in this table are in accordance with Article 4.3 of the 2014/68/EU Pressure Equipment Directive (PED)
Tous les modèles de ressorts à gaz de ce tableau sont conformes à l'article 4.3 de la directive 2014/68/UE sur les équipements sous pression (PED)

REPAIR KIT / KIT DE RÉPARATION

Gas spring code Code des ressorts à gaz	Repair kit code Code du kit de réparation
AGS170-...-A	KR/AGS170-A
AGS320-...-A	KR/AGS320-A

Download repair instructions from www.bordignon.com /
Téléchargez les instructions de réparation de www.bordignon.com

FORCE RISE VS. USED STROKE LENGTH CHARTS

The force curves in the charts below are obtained from reference values measured in static conditions. The actual forces generated under use conditions may vary, since they depend on the specific parameters of the application, such as the working speed (cycles per minute).

GRAP. AUGM. DE LA FORCE VS. COURSE UTILISÉE

Les courbes de force dans les tableaux ci-dessous sont obtenues à partir de valeurs de référence mesurées dans des conditions statiques. Les forces réelles générées dans les conditions d'utilisation peuvent varier, car elles dépendent des paramètres spécifiques de l'application, tels que la vitesse de travail (cycles par minute).

AGS170

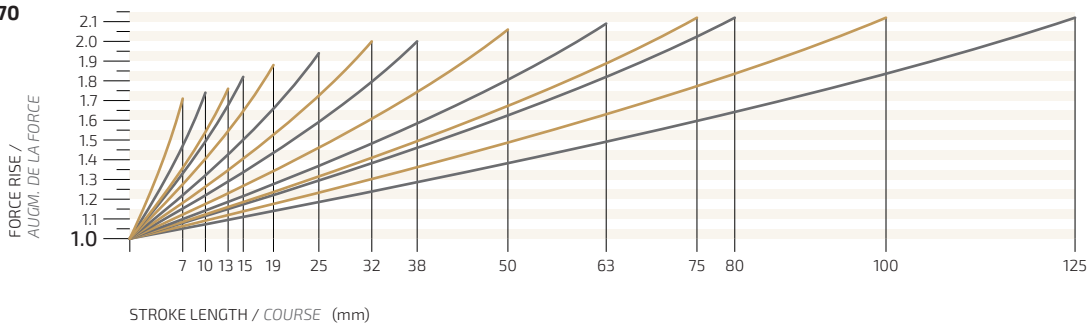

AGS320

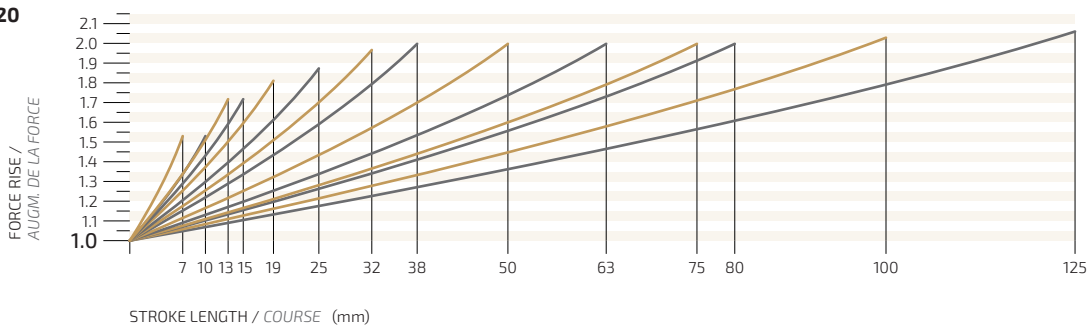

AGS

350~2400



ISO 11901-3 VDI 3003 Part 3

This gas spring series includes the models compliant with automotive standards /

La série de ressorts à gaz comprend les modèles conformes aux normes autos

BMW	B2 4005	Nissan	K32H2
FCA	075.90.60	PSA	E24.54.815.G
Ford	W-DX35-6204	VW	39D 997
MB	B8 3180 220 000 004		

COMPACT POWER

COMPACT HEIGHT



AGS series nitrogen gas springs are highly appreciated in the automotive industry thanks to the compact dimensions, the fixing and linking possibilities. With the AGS series nitrogen gas springs, Bordignon now ensures a great interchangeability and a superior reliability. AGS series nitrogen gas springs are self-lubricated.

Les ressorts à gaz de la série AGS sont très appréciés dans l'industrie automobile grâce à leurs dimensions compactes, aux possibilités de fixation et de liaison. Avec les ressorts à gaz de la série AGS, Bordignon assure désormais une grande interchangeabilité et une fiabilité supérieure. Les ressorts à gaz de la série AGS sont autolubrifiants.

Piston rod surface roughness Ra ~ 0.02 µm surface µ-hardness ~ 800 HV

Tige de piston rugosité de surface Ra ~ 0.02 µm dureté µ surface ~ 800 HV

Wiper ring Racleur de tige

Rod guide Guide-tige

Rod seal Joint de tige

Single-piece body construction Construction du corps monobloc

O-ring seal Joint torique

Non-return valve Clapet anti-retour

M6 side port (charging port) (charge with nitrogen N₂ only) Port latéral M6 (port de charge) (charge avec de l'azote N₂ uniquement)

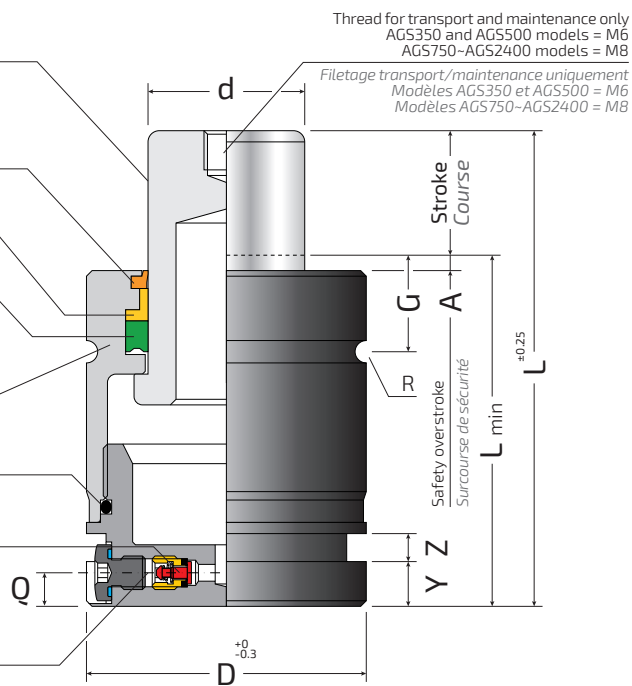

Technical notes / Notes techniques

Important use instructions in the dedicated catalogue section.
Instructions d'utilisation importantes dans la section dédiée au catalogue.

Fixing possibilities / Possibilités de fixation

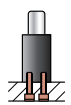

at the base with screws
à la base avec des vis

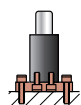

with base-plate avec plaque de base
BF, BFA, BFB, BFR

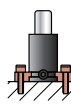

with half-flanges avec demi-brides
SF, SFA

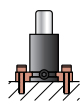

with foot brackets avec repose-pieds
ST, STA

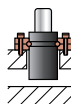

with collar flange avec bride de collier
FL, FLQ

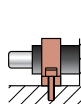

with front support avec support frontal
FT, FTA

GAS SPRING BASE / BASE DU RESSORT À GAZ

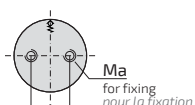

AGS350, AGS750, AGS1000, AGS1200

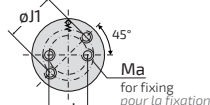

AGS500

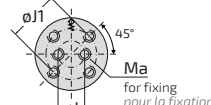

AGS1500

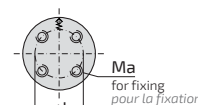

AGS2400

LINKING TO OPEN SYSTEM / LIAISON AU SYSTÈME OUVERT

Hoses Tuyaux	AGS350-AGS2400 (M6 side port / Port latéral M6)	
	Gas spring-hose fittings Raccords ressort de gaz - tuyau	ATM
	ARM	ARNM

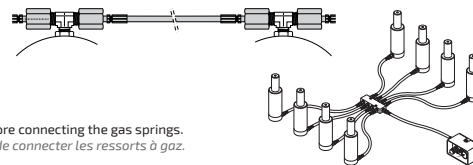

⚠ ATTENTION! Follow the instructions in the "LINKED SYSTEM" section before connecting the gas springs.
ATTENTION! Suivez les instructions de la section « SYSTÈME LIÉ » avant de connecter les ressorts à gaz.

LINKING TO "OV SYSTEM" / LIEN VERS LE « SYSTÈME OV »

"OV-version" (without valve, for direct connection to alternative manifold system) are also available. See dedicated catalogue section.
La « version OV » (sans vanne, pour un raccordement direct à un système de collecteur alternatif) est également disponible. Voir la section dédiée au catalogue.



SAFETY PROTECTIONS / PROTECTIONS DE SÉCURITÉ



UNCONTROLLED RETURN SPEED / VITESSE DE RETOUR INCONTRÔLÉE



OVERSTROKE / SURCOURSE



OVERPRESSURE / SURPRESSION

FORCE RISE VS. USED STROKE LENGTH CHARTS

GRAP. AUGM. DE LA FORCE VS. COURSE UTILISÉE

The force curves in the charts below are obtained from reference values measured in static conditions. The actual forces generated under use conditions may vary, since they depend on the specific parameters of the application, such as the working speed (cycles per minute).

Les courbes de force dans les tableaux ci-dessous sont obtenues à partir de valeurs de référence mesurées dans des conditions statiques. Les forces réelles générées dans les conditions d'utilisation peuvent varier, car elles dépendent des paramètres spécifiques de l'application, tels que la vitesse de travail (cycles par minute).

AGS350

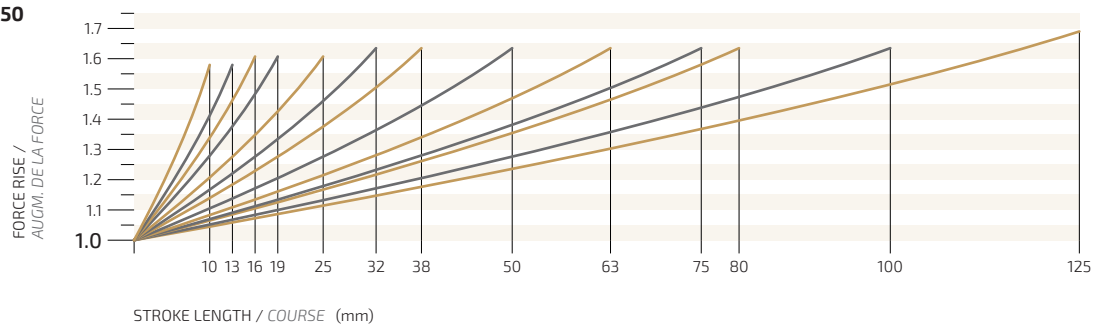

AGS500

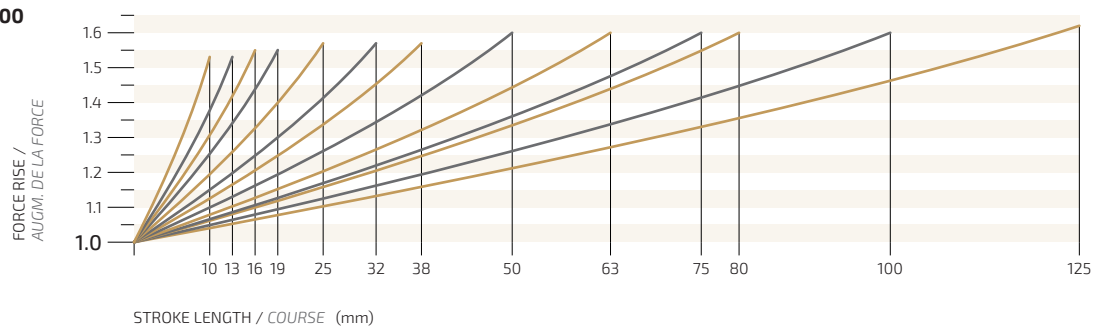

AGS750

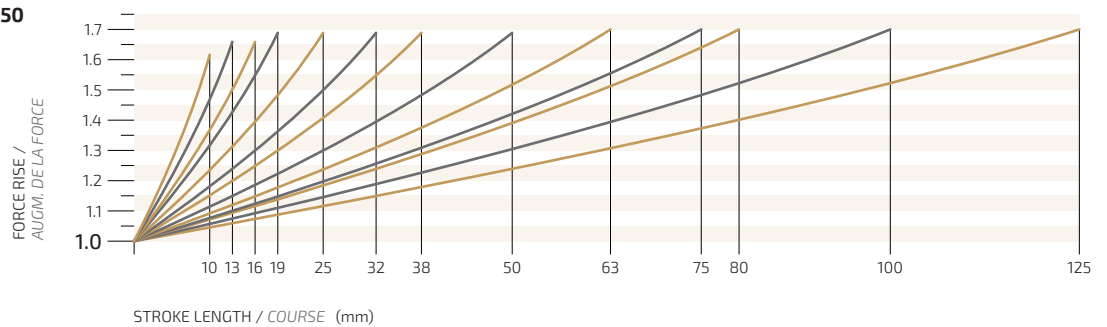

AGS1000

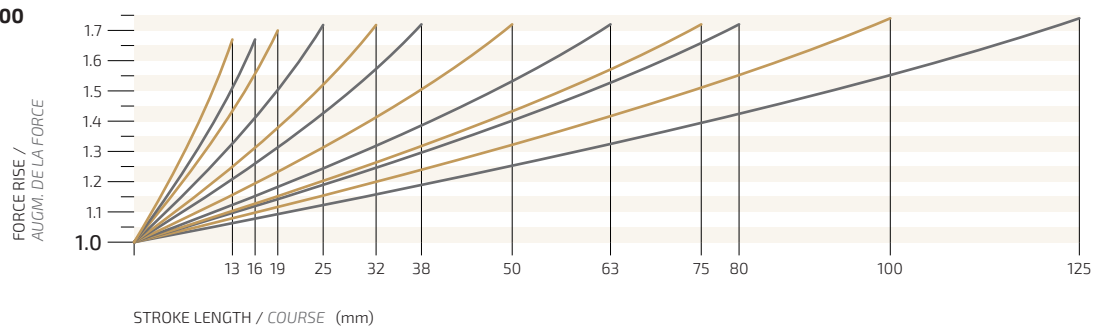

FORCE RISE VS. USED STROKE LENGTH CHARTS

GRAP. AUGM. DE LA FORCE VS. COURSE UTILISÉE

The force curves in the charts below are obtained from reference values measured in static conditions. The actual forces generated under use conditions may vary, since they depend on the specific parameters of the application, such as the working speed (cycles per minute).

Les courbes de force dans les tableaux ci-dessous sont obtenues à partir de valeurs de référence mesurées dans des conditions statiques. Les forces réelles générées dans les conditions d'utilisation peuvent varier, car elles dépendent des paramètres spécifiques de l'application, tels que la vitesse de travail (cycles par minute).

AGS1200

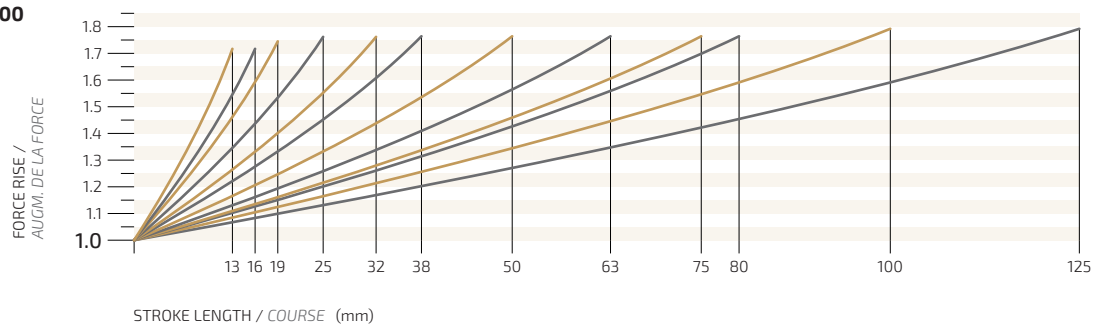

AGS1500

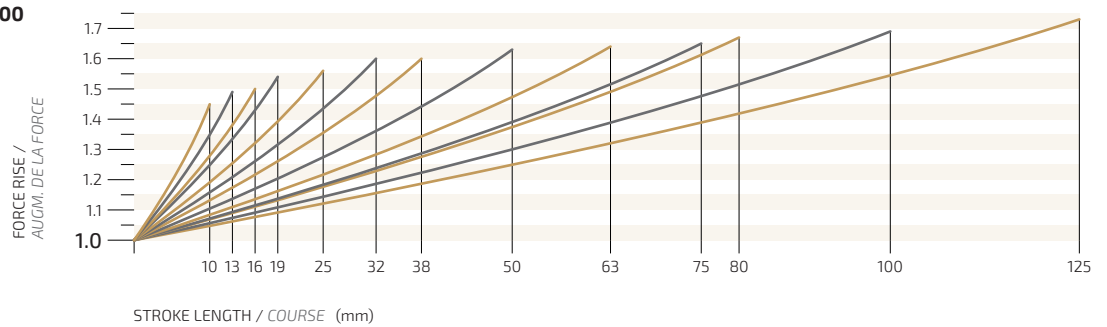

AGS2400

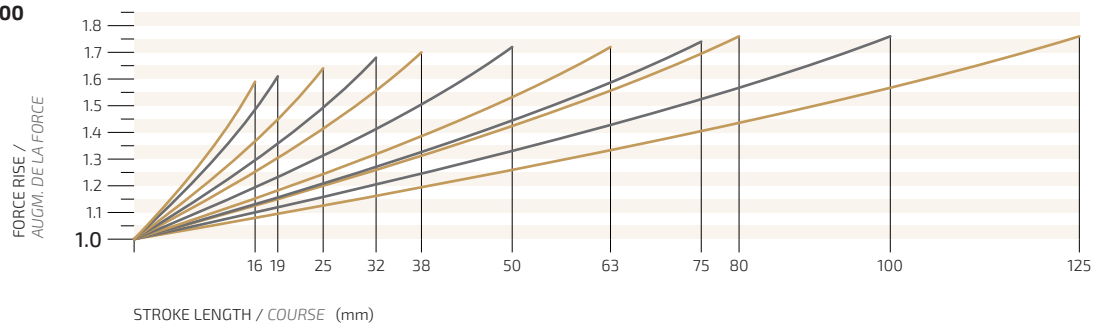

AGS



ISO 11901-3 VDI 3003 Part 3

This gas spring series includes the models compliant with automotive standards / La série de ressorts à gaz comprend les modèles conformes aux normes autos

BMW	B2 4005	MB	B8 3180 220 000 004
FCA	075.90.60	PSA	E24.54.815.G
Ford	W-DX35-6204	VW	39D 997
Mazda	PG24D		

4200~20000



AGS series nitrogen gas springs are highly appreciated in the automotive industry thanks to the compact dimensions, the fixing and linking possibilities. With the AGS series nitrogen gas springs, Bordignon now ensures a great interchangeability and a superior reliability. AGS series nitrogen gas springs are self-lubricated.

Les ressorts à gaz de la série AGS sont très appréciés dans l'industrie automobile grâce à leurs dimensions compactes, aux possibilités de fixation et de liaison. Avec les ressorts à gaz de la série AGS, Bordignon assure désormais une grande interchangeabilité et une fiabilité supérieure. Les ressorts à gaz de la série AGS sont autolubrifiants.

Piston rod surface roughness Ra ~ 0.02 µm surface µ-hardness ~ 800 HV

Tige de piston rugosité de surface Ra ~ 0.02 µm dureté µ surface ~ 800 HV

Wiper ring
Racleur de tige

Rod guide
Guide-tige

Rod seal
Joint de tige

Single-piece body construction
Construction du corps monobloc

O-ring seal
Joint torique

Non-return valve
Clapet anti-retour

G1/8 side port (charging port)
(charge with nitrogen N₂ only)
Port latéral G1/8 (port de charge)
(charge avec de l'azote N₂ uniquement)

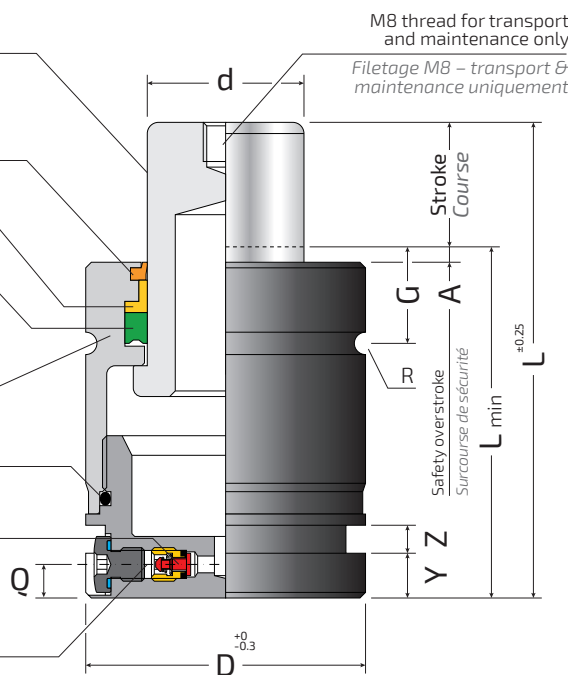

Technical notes / Notes techniques

Important use instructions in the dedicated catalogue section. Instructions d'utilisation importantes dans la section dédiée au catalogue.

Fixing possibilities / Possibilités de fixation

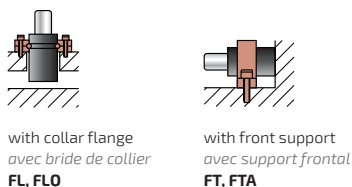
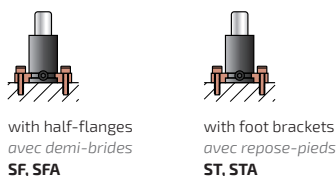
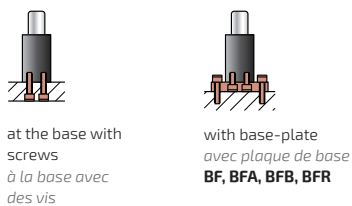

GAS SPRING BASE / BASE DU RESSORT À GAZ

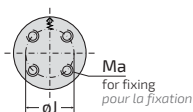

AGS4200-AGS20000

LINKING TO OPEN SYSTEM / LIAISON AU SYSTÈME OUVERT

	AGS4200-AGS20000 (G1/8 side port / Port latéral G1/8)		
Hoses Tuyaux	ATM	ATN	AT
Gas spring-hose fittings Raccords ressort de gaz - tuyau	ARM	ARN	AR

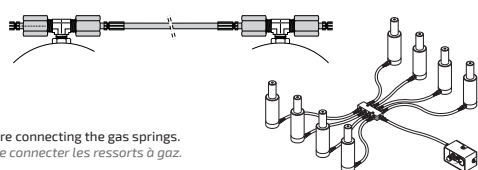

ATTENTION! Follow the instructions in the "LINKED SYSTEM" section before connecting the gas springs. ATTENTION! Suivez les instructions de la section « SYSTÈME LIÉ » avant de connecter les ressorts à gaz.

LINKING TO "OV SYSTEM" / LIEN VERS LE « SYSTÈME OV »

"OV-version" (without valve, for direct connection to alternative manifold system) are also available. See dedicated catalogue section. La « version OV » (sans vanne, pour un raccordement direct à un système de collecteur alternatif) est également disponible. Voir la section dédiée au catalogue.



SAFETY PROTECTIONS / PROTECTIONS DE SÉCURITÉ



UNCONTROLLED RETURN SPEED / VITESSE DE RETOUR INCONTRÔLÉE



OVERSTROKE / SURCOURSE



OVERPRESSURE / SURPRESSION

Model Modèle	MAX Stroke 100% usable MAX course 100% utilisable		D mm	d mm	G mm	A mm	R mm	Y mm	Z mm	Q mm	Ma	J mm	bar (MPa)	daN	daN	Cycles per minute MAX Cycles par minute MAX	Gas volume volume dm ³	Weight Poids kg	
	Lmin mm	L mm																	
AGS4200 -16-A	16	74	90													6800	190	0.13	3.13
19-A	19	77	96													6800	160	0.15	3.21
25-A	25	83	108													7000	120	0.19	3.37
32-A	32	90	122													7300	90	0.24	3.55
38-A	38	96	134													7300	80	0.28	3.69
50-A	50	108	158	95	60	24	3	2.5	8	5	10.5	M8 x 12 (4x)	60	150 (15.0)	4240	7500	60	0.36	3.98
63-A	63	121	184													7500	50	0.45	4.30
75-A	75	133	208													7600	40	0.54	4.59
80-A	80	138	218													7700	40	0.57	4.72
100-A	100	158	258													7800	30	0.71	5.22
125-A	125	183	308													7900	25	0.88	5.85
AGS6600 -16-A	16	84	100													9400	190	0.22	5.67
19-A	19	87	106													9600	160	0.25	5.81
25-A	25	93	118													10100	120	0.31	6.08
32-A	32	100	132													10400	90	0.38	6.39
38-A	38	106	144													10500	80	0.44	6.66
50-A	50	118	168	120	75	25.5	3	2.5	8	5	10.5	M10 x 12 (4x)	80	150 (15.0)	6630	10700	60	0.56	7.21
63-A	63	131	194													11200	50	0.69	7.79
75-A	75	143	218													11300	40	0.81	8.32
80-A	80	148	228													11300	40	0.86	8.53
100-A	CE	100	268													11400	30	1.07	9.45
125-A	CE	125	318													11500	25	1.32	10.57
AGS9500 -19-A	19	97	116													16000	160	0.35	10.85
25-A	25	103	128													16300	120	0.45	11.23
32-A	32	110	142													16500	90	0.56	11.69
38-A	38	116	154													16600	80	0.65	12.06
50-A	50	128	178	150	90	27.5	3	2.5	8	5	10.5	M10 x 16 (4x)	100	150 (15.0)	9540	16800	60	0.85	12.84
63-A	CE	63	204													17000	50	1.05	13.67
75-A	CE	75	228													17000	40	1.24	14.45
80-A	CE	80	238													17100	40	1.32	14.77
100-A	CE	100	278													17100	30	1.64	16.05
125-A	CE	125	328													17200	25	2.04	17.67
AGS20000 -19-A	19	129	148													30400	160	0.90	23.29
25-A	CE	25	160													31600	120	1.08	23.92
32-A	CE	32	174													32600	90	1.29	24.66
38-A	CE	38	186													33300	80	1.47	25.30
50-A	CE	50	210	195	130	33.5	3	2.5	8	8	15	M12 x 18 (4x)	120	150 (15.0)	19910	34400	60	1.83	26.55
63-A	CE	63	236													35100	50	2.22	27.91
75-A	CE	75	260													35600	40	2.58	29.17
80-A	CE	80	270													35800	40	2.73	29.69
100-A	CE	100	310													36400	30	3.33	31.80
125-A	CE	125	360													36900	25	4.08	34.42

CE The gas spring models for which the CE symbol is indicated have an internal gas volume > 1 litre (1 dm³). They fall into Category II of the 2014/68/EU Pressure Equipment Directive (PED).

All the other gas spring models in this table are in accordance with Article 4.3 of the 2014/68/EU Pressure Equipment Directive (PED).

Les modèles de ressort à gaz pour lesquels le symbole CE est indiqué ont un volume de gaz interne > 1 litre (1 dm³). Ils entrent dans la catégorie II de la directive 2014/68/UE sur les équipements sous pression (PED).

Tous les autres modèles de ressorts à gaz de ce tableau sont conformes à l'article 4.3 de la directive 2014/68/UE sur les équipements sous pression (PED).

"L-VERSION" (FOR LINKED SYSTEM) / « VERSION L » (POUR SYSTÈME LIÉ)

When the gas springs are to be used in a linked system, make sure to order the "L-version" by adding "-L" after the gas spring code. The "L-version" gas springs are supplied already discharged and without valve, ready for the connection to linked system.

Example: "AGS6600-50-A-L"

Lorsque les ressorts à gaz doivent être utilisés dans un système lié, assurez-vous de commander la « version L » en ajoutant « -L » après le code du ressort à gaz. Les ressorts à gaz « version L » sont fournis déjà déchargés et sans vanne, prêts pour le raccordement au système lié.

Exemple: "AGS6600-50-A-L"

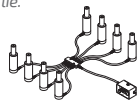

REPAIR KIT / KIT DE RÉPARATION

Gas spring code Code des ressorts à gaz	Repair kit code Code du kit de réparation
AGS4200-...-A	KR/AGS4200-A
AGS6600-...-A	KR/AGS6600-A
AGS9500-...-A	KR/AGS9500-A
AGS20000-...-A	KR/AGS20000-A

Download repair instructions from www.bordignon.com /
Téléchargez les instructions de réparation de www.bordignon.com

FORCE RISE VS. USED STROKE LENGTH CHARTS

GRAP. AUGM. DE LA FORCE VS. COURSE UTILISÉE

The force curves in the charts below are obtained from reference values measured in static conditions. The actual forces generated under use conditions may vary, since they depend on the specific parameters of the application, such as the working speed (cycles per minute).

Les courbes de force dans les tableaux ci-dessous sont obtenues à partir de valeurs de référence mesurées dans des conditions statiques. Les forces réelles générées dans les conditions d'utilisation peuvent varier, car elles dépendent des paramètres spécifiques de l'application, tels que la vitesse de travail (cycles par minute).

AGS4200

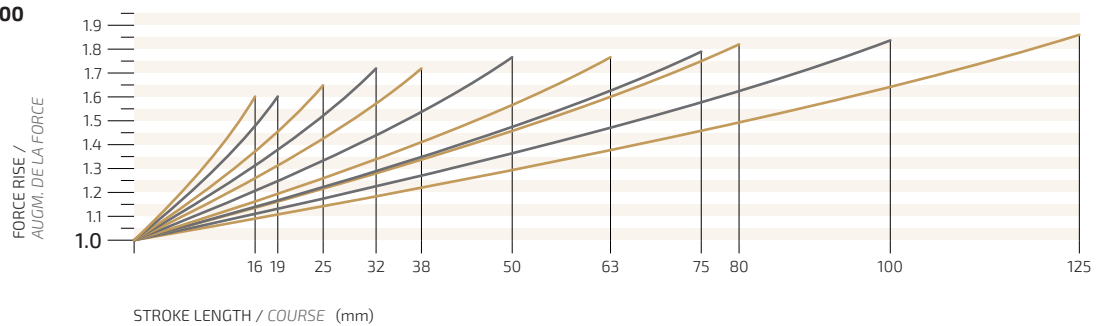

AGS6600

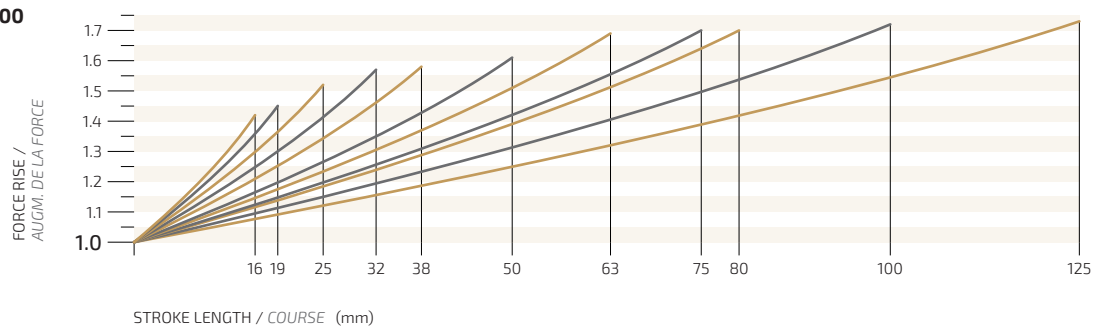

AGS9500

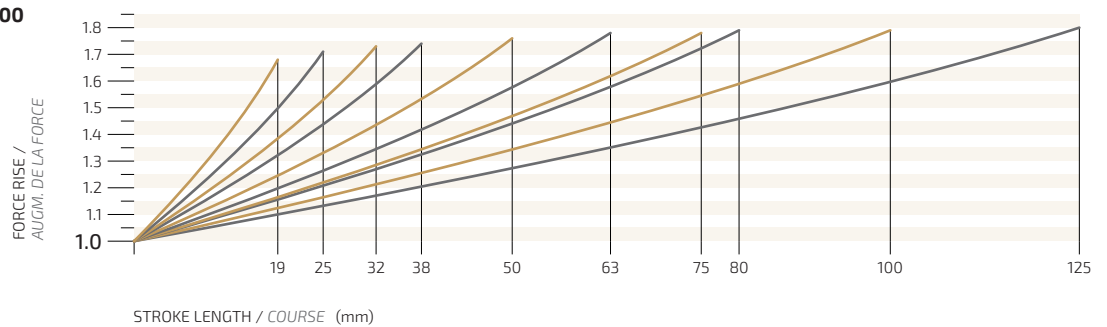

AGS20000

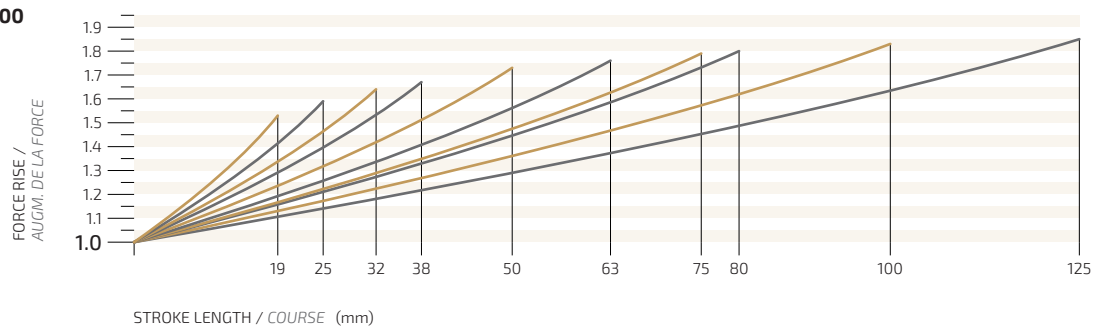

400~20000

COMPACT POWER

COMPACT HEIGHT



TGS series nitrogen gas springs feature high forces and compact diameters in a rod seal design. They ensure a great interchangeability (forces, dimensions and fixing possibilities) with the bore seal design nitrogen gas springs commonly available on the market, offering a higher performance (high number of cycles per minute, self-lubrication, better protection against liquid contaminants) and reliability thanks to the rod seal design. TGS series nitrogen gas springs are self-lubricated.

Les ressorts à gaz de la série TGS se caractérisent par des forces élevées et des diamètres compacts dans une conception de joint de tige. Ils assurent une grande interchangeabilité (forces, dimensions et possibilités de fixation) avec la conception des ressorts à gaz de conception d'alésage couramment disponibles sur le marché, offrant des performances supérieures (nombre élevé de cycles par minute, autolubrification, meilleure protection contre les contaminants liquides) et une fiabilité grâce à la conception du joint de tige. Les ressorts à gaz de la série TGS sont autolubrifiants.

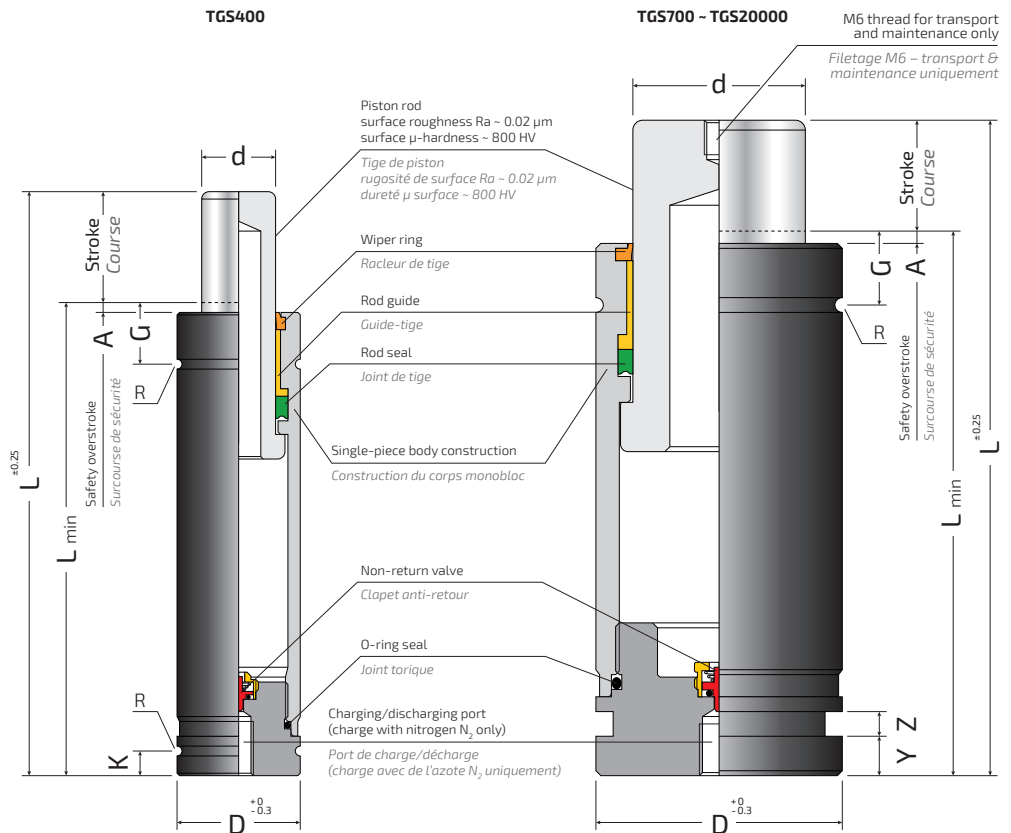

Technical notes / Notes techniques
Important use instructions in the dedicated catalogue section.
Instructions d'utilisation importantes dans la section dédiée au catalogue.

Fixing possibilities / Possibilités de fixation

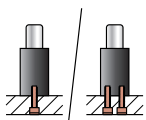

at the base with screw(s)
à la base avec vis(s)

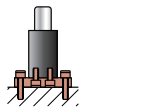

with base-plate avec plaque de base
BF, BFA, BFB, BFR

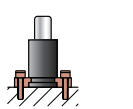

with half-flanges avec demi-bridges
SF, SFA

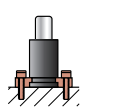

with foot brackets avec repose-pieds
ST, STA

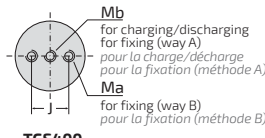

TGS400

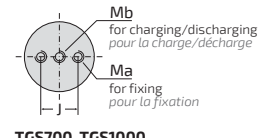

TGS700, TGS1000, TGS2000, TGS3000

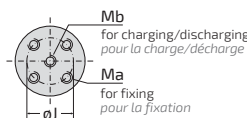

TGS5000, TGS8000, TGS12000, TGS20000

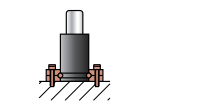

with collar flange (base) avec bride de collier (base)
FL

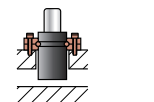

with collar flange avec bride de collier
FL, FLA, FLQ, FLQA

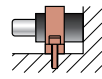

with front support avec support frontal
FT, FTA

SAFETY PROTECTIONS / PROTECTIONS DE SÉCURITÉ





UNCONTROLLED RETURN SPEED / VITESSE DE RETOUR INCONTRÔLÉE



OVERSTROKE / SURCOURSE



OVERPRESSURE / SURPRESSION

Model Modèle	MAX Stroke 100% usable MAX course 100% utilisable		L min mm	L mm	D mm	d mm	G mm	A mm	R mm	K mm	Y mm	Z mm	Ma mm	J mm	Mb mm	 bar (MPa)	 daN	 daN	Cycles per minute MAX Cycles par minute MAX	Gas volume Gaz volume dm ³	Weight Poids kg	
	L	L																				
TGS400 -10-A	10	60	70				11.5		1		-	-							510	300	0.006	0.18
16-A	16	75	91				11.5		1		-	-							510	190	0.011	0.20
25-A	25	95	120				11.5		1		-	-							520	120	0.018	0.24
32-A	32	108	140	25	15		11.5	1	5		-	-	M5 x 6 (2x)	14	M6 x 11	204 (20.4)	360		520	90	0.022	0.26
40-A	40	125	165				11.5		1		-	-							530	75	0.028	0.30
50-A	50	145	195				11.5		1		-	-							530	60	0.035	0.33
TGS700 -06-A ●	6	57	63				11.5		1		-	-							840	300	0.008	0.27
10-A ●	10	65	75				11.5		1		-	-							870	300	0.014	0.29
16-A	16	77	93				11.5		1		4	3.5							940	190	0.018	0.33
25-A	25	95	120	32	20		11.5	2	1	-	4	3.5	M6 x 8 (2x)	15	M4	210 (21.0)	660		950	120	0.030	0.38
32-A	32	108	140				11.5		1		4	3.5							950	90	0.038	0.42
40-A	40	125	165				11.5		1		4	3.5							960	75	0.049	0.46
50-A	50	145	195				11.5		1		4	3.5							960	60	0.062	0.51
TGS1000 -06-A ●	6	55	61				10.5		1		-	-							1350	300	0.010	0.38
10-A	10	68	78				10.5		1		4	3.5							1400	300	0.016	0.46
16-A	16	84	100				10.5		1		4	3.5							1400	190	0.028	0.52
25-A	25	110	135	38	25		10.5	2	1	-	4	3.5	M6 x 8 (2x)	17	M8	205 (20.5)	1000		1400	120	0.049	0.63
32-A	32	135	167				10.5		1		4	3.5							1450	90	0.068	0.73
40-A	40	155	195				10.5		1		4	3.5							1450	75	0.084	0.81
50-A	50	180	230				10.5		1		4	3.5							1450	60	0.104	0.92
TGS2000 -06-A ●●	6	60	66				-		-		-	-							3000	300	0.02	0.74
10-A ●●	10	70	80				-		-		-	-							3100	300	0.03	0.82
16-A ●●	16	90	106				14.5		1.5		-	-							3200	190	0.05	1.02
25-A	25	110	135				14.5		1.5		8	5							3300	120	0.07	1.25
32-A	32	130	162	50	35		14.5	2	1.5	-	8	5	M6 x 8 (2x)	26	M8	209 (20.9)	2000		3400	90	0.10	1.39
40-A	40	150	190				14.5		1.5		8	5							3400	75	0.12	1.54
50-A	50	170	220				14.5		1.5		8	5							3400	60	0.15	1.70
65-A	65	206	271				14.5		1.5		8	5							3200	45	0.20	1.99
TGS3000 -10-A ●●	10	75	85				-		-		-	-							4600	300	0.05	1.45
16-A ●●	16	87	103				19		2		-	-							5000	190	0.07	1.62
25-A	25	105	130				19		2		8	5							5200	120	0.10	1.91
32-A	32	118	150	63	45		19	2	2	-	8	5	M8 x 12 (2x)	34	M8	189 (18.9)	3000		5200	90	0.14	2.07
40-A	40	135	175				19		2		8	5							5300	75	0.18	2.27
50-A	50	155	205				19		2		8	5							5300	60	0.23	2.52
65-A	65	191	256				19		2		8	5							5000	45	0.31	2.97
TGS5000 -10-A ●●●	10	70	80				-		-		-	-							7400	300	0.08	1.87
16-A ●●●	16	90	106				18		1.5		-	-							7400	190	0.12	2.33
25-A	25	110	135				18		1.5		8	5							7600	120	0.18	2.74
32-A	32	135	167	75	58		18	2	1.5	-	8	5	M8 x 12 (4x)	40	M8	190 (19.0)	5000		7600	90	0.27	3.05
40-A	40	160	200				18		1.5		8	5							7600	75	0.36	3.38
50-A	50	190	240				18		1.5		8	5							7200	60	0.47	3.78
65-A	65	208	273				18		1.5		8	5							8000	45	0.55	4.12
TGS8000 -10-A ●●●	10	80	90				-		-		-	-							10500	300	0.17	3.29
16-A ●●●	16	100	116				21		1.5		-	-							10800	190	0.25	3.94
25-A	25	120	145				21		1.5		8	5							11500	120	0.36	4.50
32-A	32	150	182	95	75		21	2	1.5	-	8	5	M8 x 12 (4x)	52	M8	182 (18.2)	8000		11500	90	0.54	5.05
40-A	40	170	210				21		1.5		8	5							11600	75	0.66	5.46
50-A	50	205	255				21		1.5		8	5							11600	60	0.88	6.14
65-A	65	214	279				21		1.5		8	5							12500	45	0.96	6.46
TGS12000 -10-A ●●●	10	90	100				-		-		-	-							15500	300	0.25	6.22
16-A ●●●	16	110	126				22.5		2.5		-	-							16500	190	0.35	7.45
25-A	25	130	155				22.5		2.5		8	5							17000	120	0.49	8.59
32-A	32	155	187	120	90		22.5	2	2.5	-	8	5	M10 x 15 (4x)	68	M8	189 (18.9)	12000		17000	90	0.70	9.48
40-A	40	180	220				22.5		2.5		8	5							17000	75	0.92	10.41
50-A ●	50	210	260				22.5		2.5		8	5							16500	60	1.19	11.52
65-A ●	65	255	320				22.5		2.5		8	5							18000	45	1.59	13.27
TGS20000 -10-A ●●●●	10	100	110				-		-		-	-							29500	300	0.41	10.54
16-A ●●●●	16	120	136				24.5		2.5		-	-							31000	190	0.57	12.54
25-A	25	140	165				24.5		2.5		8	5							32500	120	0.79	14.36
32-A ●	32	165	197	150	115		24.5	2	2.5	-	8	5	M10 x 15 (4x)	90	M8	193 (19.3)	20000		31000	90	1.15	15.73
40-A ●	40	195	235				24.5		2.5		8	5							30500	75	1.51	17.45
50-A ●	50	220	270				24.5		2.5		8	5							30000	60	1.94	18.91
65-A ●	65	258	323				24.5		2.5		8	5							30000	45	2.50	21.29

- Without lower (square) groove / Sans rainure inférieure (carrée)
- Without upper (round) groove / Sans rainure supérieure (ronde)

● The gas spring models for which the CE symbol is indicated have an internal gas volume > 1 litre (1 dm³). They fall into Category II of the 2014/68/EU Pressure Equipment Directive (PED).

All the other gas spring models in this table are in accordance with Article 4.3 of the 2014/68/EU Pressure Equipment Directive (PED).

Les modèles à ressort à gaz pour lesquels le symbole CE est indiqué ont un volume de gaz interne > 1 litre (1 dm³). Ils entrent dans la catégorie II de la directive 2014/68/UE sur les équipements sous pression (PED).

Tous les autres modèles de ressorts à gaz de ce tableau sont conformes à l'article 4.3 de la directive 2014/68/UE sur les équipements sous pression (PED).

REPAIR KIT / KIT DE RÉPARATION

Gas spring code Code des ressorts à gaz	Repair kit code Code du kit de réparation	Gas spring code Code des ressorts à gaz	Repair kit code Code du kit de réparation
TGS400-...-A	KR/TGS400-A	TGS8000-10-A	KR/TGS8000-A-1
TGS700-...-A	KR/TGS700-A	TGS8000-16-A - TGS8000-65-A	KR/TGS8000-A-2
TGS1000-...-A	KR/TGS1000-A	TGS12000-10-A	KR/TGS12000-A-1
TGS2000-06-A, TGS2000-10-A	KR/T		

FORCE RISE VS. USED STROKE LENGTH CHARTS

GRAP. AUGM. DE LA FORCE VS. COURSE UTILISÉE

The force curves in the charts below are obtained from reference values measured in static conditions. The actual forces generated under use conditions may vary, since they depend on the specific parameters of the application, such as the working speed (cycles per minute).

Les courbes de force dans les tableaux ci-dessous sont obtenues à partir de valeurs de référence mesurées dans des conditions statiques. Les forces réelles générées dans les conditions d'utilisation peuvent varier, car elles dépendent des paramètres spécifiques de l'application, tels que la vitesse de travail (cycles par minute).

TGS400

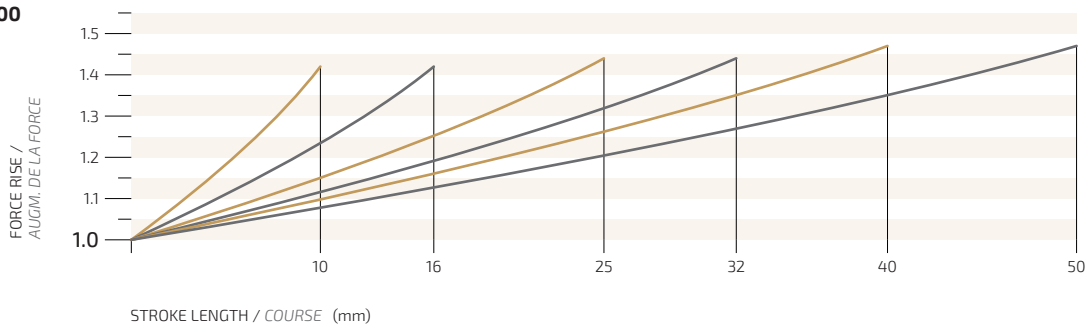

TGS700

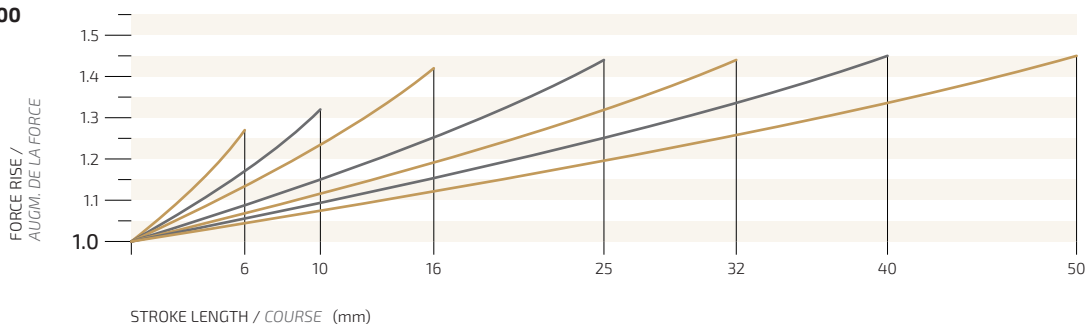

TGS1000

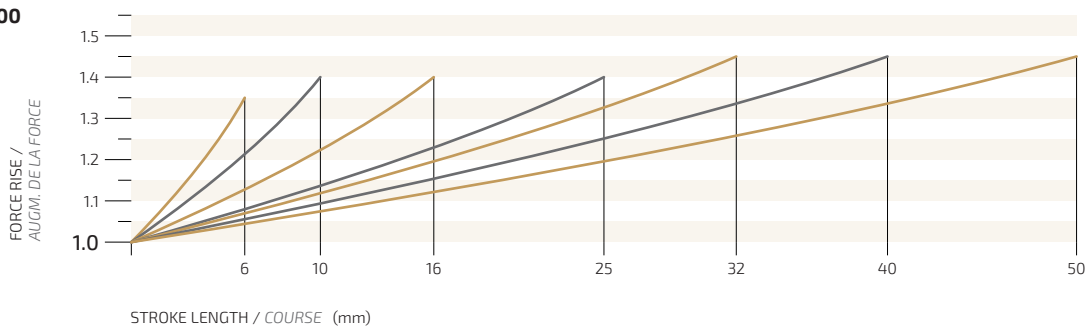

TGS2000

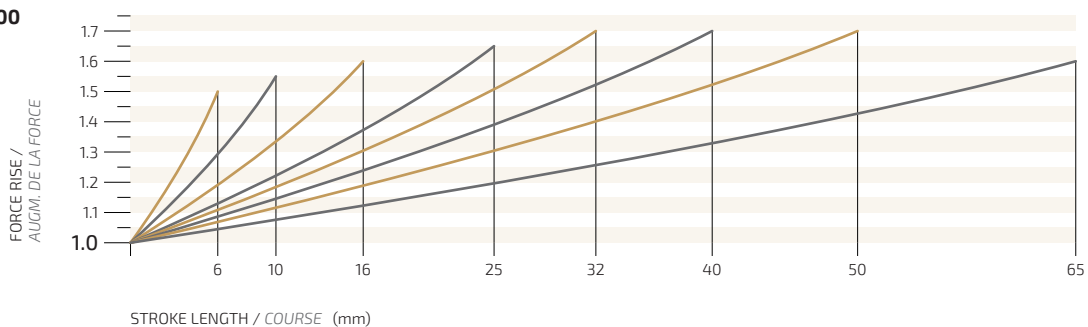

TGS3000

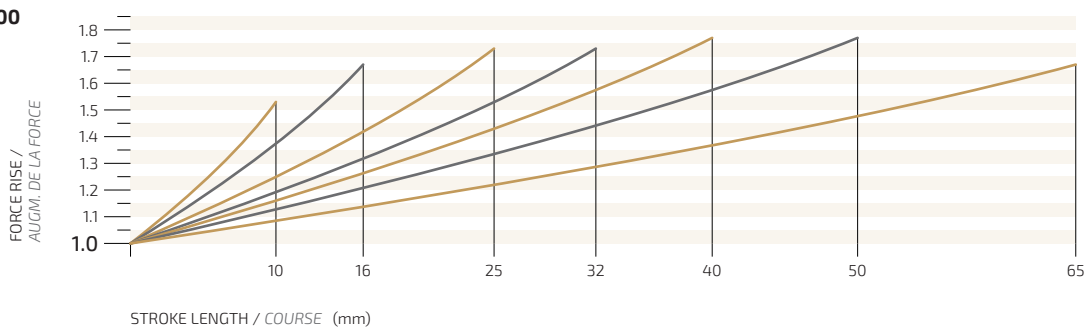

FORCE RISE VS. USED STROKE LENGTH CHARTS

GRAP. AUGM. DE LA FORCE VS. COURSE UTILISÉE

The force curves in the charts below are obtained from reference values measured in static conditions. The actual forces generated under use conditions may vary, since they depend on the specific parameters of the application, such as the working speed (cycles per minute).

Les courbes de force dans les tableaux ci-dessous sont obtenues à partir de valeurs de référence mesurées dans des conditions statiques. Les forces réelles générées dans les conditions d'utilisation peuvent varier, car elles dépendent des paramètres spécifiques de l'application, tels que la vitesse de travail (cycles par minute).

TGS5000

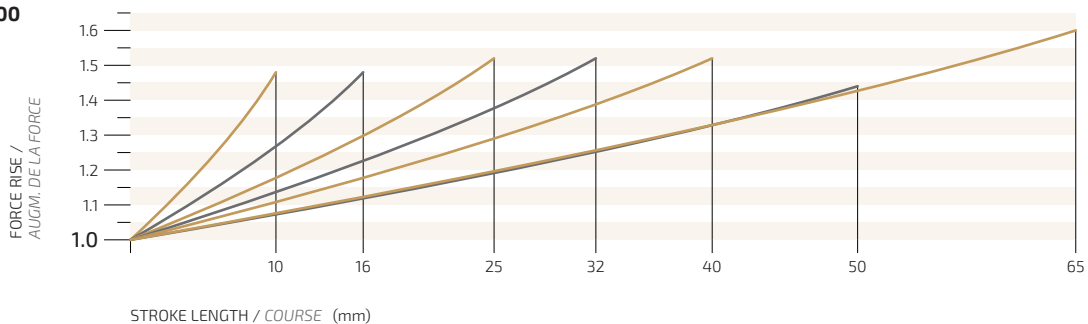

TGS8000

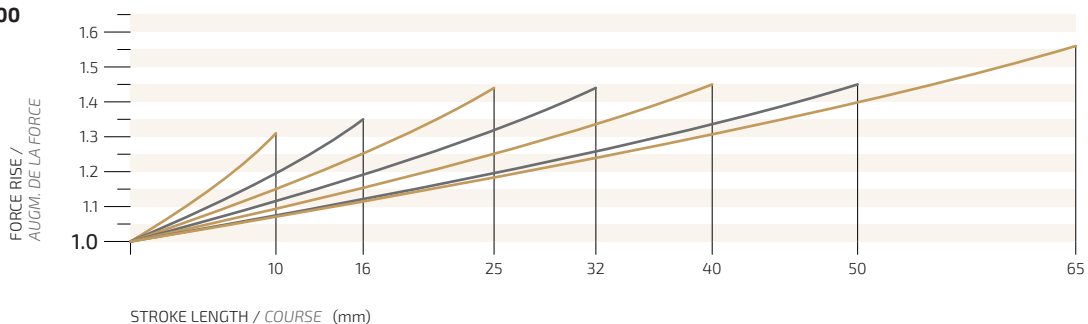

TGS12000

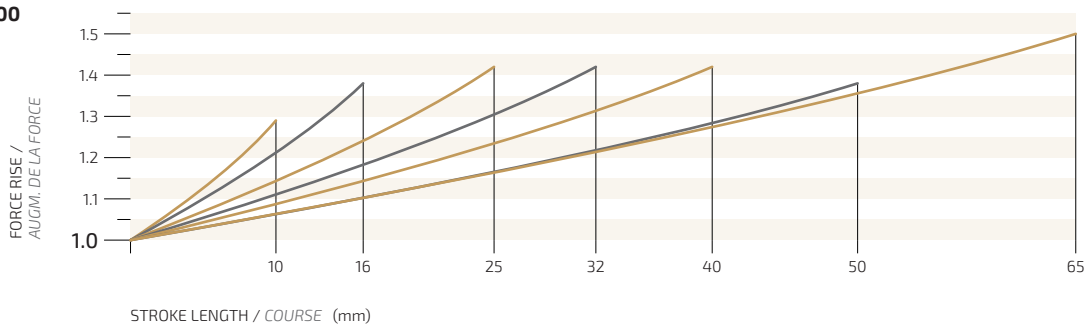

TGS20000

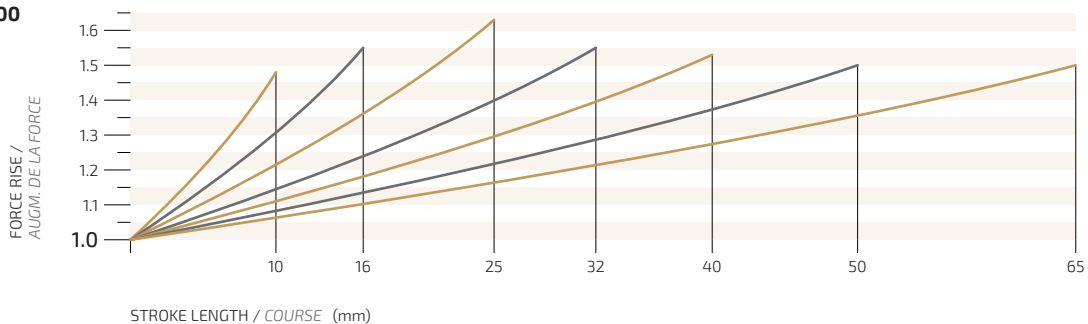



This gas spring series includes the models compliant with automotive standards / La série de ressorts à gaz comprend les modèles conformes aux normes autos

BMW	B2 4006	Nissan	K325, K32C
FCA	075.90.55	PSA	E24.54.815.G
Ford	W-DX35-6203	Renault	EM24.54.700
Mazda	PG23D	Suzuki	SES-K 5404e
MB	B8 3180 220 000 001	VW	39D 878



Technical notes / Notes techniques
Important use instructions in the dedicated catalogue section.
Instructions d'utilisation importantes dans la section dédiée au catalogue.

IGS series nitrogen gas springs feature standard dimensions and forces, as well as several fixing and linking possibilities. With the IGS series nitrogen gas springs, Bordignon now ensures a great interchangeability and a superior reliability. IGS series nitrogen gas springs are self-lubricated.

Les ressorts à gaz de la série IGS présentent des dimensions et des forces standard, ainsi que plusieurs possibilités de fixation et de liaison. Avec les ressorts à gaz azoté de la série IGS, Bordignon assure désormais une grande interchangeabilité et une fiabilité supérieure. Les ressorts à gaz de la série IGS sont autolubrifiants.

Piston rod surface roughness Ra ~ 0.02 µm
surface µ-hardness ~ 800 HV
Tige de piston rugosité de surface Ra ~ 0.02 µm
dureté µ surface ~ 800 HV

Wiper ring
Racleur de tige

Rod guide
Guide-tige

Rod seal
Joint de tige

Single-piece body construction
Construction du corps monobloc

Non-return valve
Clapet anti-retour

O-ring seal
Joint torique

Side port (charging port)
IGS150 and IGS250 models = M6
IGS500-IGS1500 = G1/8
(charge with nitrogen N₂ only)

Port latéral (port de charge)
Modèles IGS150 et IGS250 = M6
IGS500-IGS1500 = G1/8
(charge avec de l'azote N₂ uniquement)

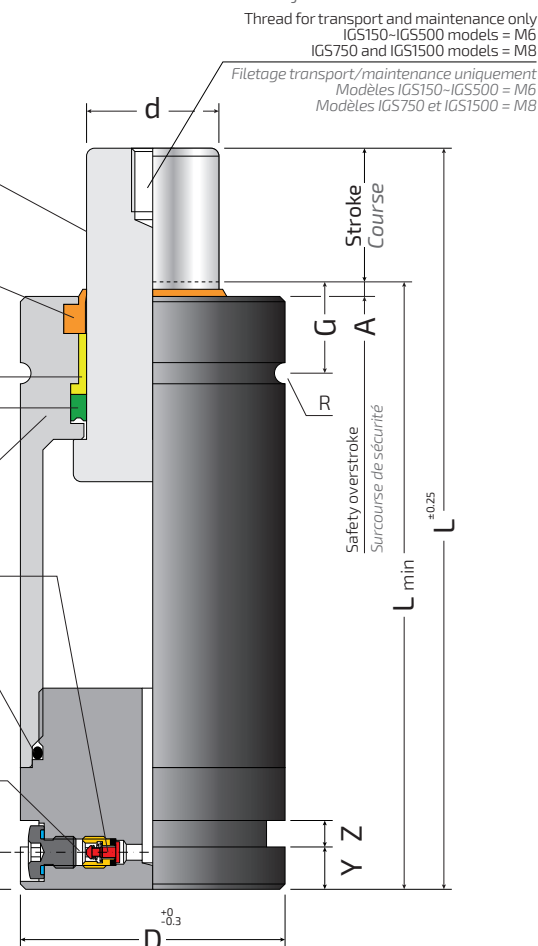

Fixing possibilities / Possibilités de fixation

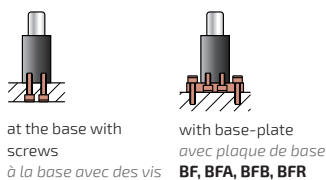

at the base with screws
à la base avec des vis

with base-plate with screws
avec plaque de base avec vis

GAS SPRING BASE / BASE DU RESSORT À GAZ

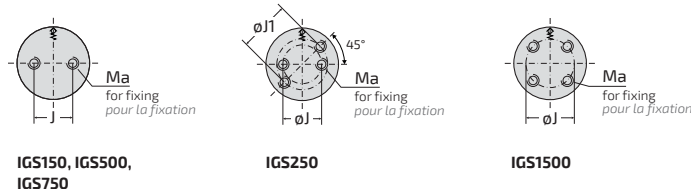

IGS150, IGS500, IGS750

IGS250

IGS1500

LINKING TO OPEN SYSTEM / LIAISON AU SYSTÈME OUVERT

Hoses Tuyaux	IGS150-IGS250 (M6 side port/ Port latéral M6)		IGS500-IGS1500 (G1/8 side port/ Port latéral G1/8)		
	ATM	ATNM	ATM	ATN	AT
Gas spring-hose fittings Raccords ressort de gaz - tuyau	ARM	ARNM	ARM	ARN	AR

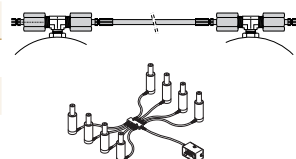

ATTENTION! Follow the instructions in the "LINKED SYSTEM" section before connecting the gas springs.
ATTENTION! Suivez les instructions de la section « SYSTÈME LIÉ » avant de connecter les ressorts à gaz.

SAFETY PROTECTIONS / PROTECTIONS DE SÉCURITÉ

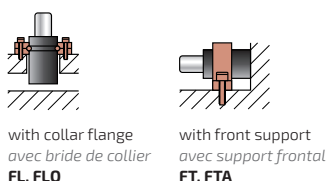

with collar flange with bride de collier
FL, FLQ

with front support with support frontal
FT, FTA



UNCONTROLLED RETURN SPEED / VITESSE DE RETOUR INCONTRÔLÉE



OVERSTROKE / SURCOURSE



OVERPRESSURE / SURPRESSION

Model Modèle	MAX Stroke 100% usable MAX course 100% utilisable		Lmin mm	L mm	D mm	d mm	G mm	A mm	R mm	Y mm	Z mm	Q mm	Ma	J mm	J1 mm	bar (MPa)	daN	daN	Cycles per minute MAX Cycles par minute MAX	Gas volume Gaz volume dm ³	Weight Poids kg
	10	60																			
IGS150 -10	10	60	70															215	300	0.009	0.30
13	12.7	62.7	75.4															220	235	0.010	0.32
16	16	66	82															220	190	0.012	0.33
25	25	75	100															225	120	0.017	0.36
38	38.1	88.1	126.2	32	12	12.5	2	1	4	4	6	M6 x 11 (2x)	18	-	150 (15.0)	170	230	80	0.024	0.39	
50	50	100	150														230	60	0.030	0.44	
63	63.5	113.5	177														230	50	0.037	0.48	
80	80	130	210														235	40	0.046	0.54	
100	100	150	250														235	30	0.057	0.60	
125	125	175	300														235	25	0.070	0.70	
IGS250 -10	10	60	70															305	300	0.029	0.30
13	12.7	62.7	75.4															310	235	0.031	0.31
16	16	66	82															310	190	0.034	0.33
19	19	69	88															315	160	0.037	0.34
25	25	75	100															320	120	0.042	0.37
38	38.1	88.1	126.2	38	15	12.5	2	1	4	4	6	M6 x 9 (J: 2x) (J1: 2x)	18	25	150 (15.0)	260	330	80	0.052	0.43	
50	50	100	150															335	60	0.062	0.48
63	63.5	113.5	177															335	50	0.074	0.54
80	80	130	210															340	40	0.087	0.61
100	100	150	250															345	30	0.104	0.66
125	125	175	300															350	25	0.125	0.83
IGS500 -10	10	95	105															570	300	0.033	0.78
13	12.7	97.7	110.4															580	235	0.036	0.87
25	25	110	135															610	120	0.051	0.95
38	38.1	123.1	161.2															630	80	0.066	1.04
50	50	135	185															640	60	0.080	1.12
63	63.5	148.5	212	45	20	16.5	2	1	4	4	10.5	M8 x 13 (2x)	20	-	150 (15.0)	470	660	50	0.095	1.20	
80	80	165	245															660	40	0.115	1.30
100	100	185	285															670	30	0.138	1.41
125	125	210	335															680	25	0.167	1.60
160	160	245	405															700	19	0.192	1.93
200	200	285	485															700	15	0.239	2.10
IGS750 -13	12.7	107.7	120.4															930	235	0.05	1.16
25	25	120	145															990	120	0.07	1.26
38	38.1	133.1	171.2															1040	80	0.09	1.37
50	50	145	195															1070	60	0.10	1.47
63	63.5	158.5	222															1090	50	0.12	1.59
75	75	170	245															1110	40	0.14	1.70
80	80	175	255															1110	40	0.15	1.74
88	87.5	182.5	270															1120	35	0.16	1.80
100	100	195	295															1130	30	0.17	1.92
113	112.5	207.5	320	50	25	17.5	3	2	8	5	10.5	M8 x 13 (2x)	20	-	150 (15.0)	740	1140	27	0.19	2.03	
125	125	220	345															1150	25	0.21	2.13
138	137.5	232.5	370															1210	22	0.21	2.36
150	150	245	395															1210	20	0.22	2.51
160	160	255	415															1220	19	0.24	2.60
175	175	270	445															1220	17	0.26	2.73
200	200	295	495															1220	15	0.30	2.94
225	225	320	545															1220	13	0.33	3.16
250	250	345	595															1220	12	0.37	3.31
275	275	370	645															1230	11	0.40	3.59
300	300	395	695															1230	10	0.44	3.81
IGS1500 -13	12.7	122.3	135															1870	235	0.13	3.01
25	25	135	160															1980	120	0.17	3.27
38	38.1	148.1	186.2															2060	80	0.21	3.51
50	50	160	210															2110	60	0.25	3.73
63	63.5	173.5	237															2160	50	0.29	3.97
75	75	185	260															2190	40	0.33	4.18
80	80	190	270															2200	40	0.35	4.27
88	87.5	197.5	285															2220	35	0.37	4.39
100	100	210	310															2240	30	0.41	4.63
113	112.5	222.5	335	75	36	21	3	2.5	8	5	10.5	M8 x 13 (4x)	40	-	150 (15.0)	1530	2260	27	0.45	4.84	
125	125	235	360															2270	25	0.49	5.08
138	137.5	247.5	385															2390	22	0.47	5.77
150	150	260	410															2400	20	0.51	5.99
160	160	270	430															2400	19	0.55	6.17
175	175	285	460															2410	17	0.59	6.45
200	200	310	510															2410	15	0.67	6.90
225	225	335	560															2420	13	0.75	7.35
250	250	360	610															2420	12	0.83	7.81
275	275	385	660															2430	11	0.92	8.26
300	300	410	710															2430	10	0.99	8.72

All the gas spring models in this table are in accordance with Article 4.3 of the 2014/68/EU Pressure Equipment Directive (PED)

Tous les modèles de ressorts à gaz de ce tableau sont conformes à l'article 4.3 de la directive 2014/68/UE sur les équipements sous pression (PED)

"L-VERSION" (FOR LINKED SYSTEM) / « VERSION L » (POUR SYSTÈME LIÉ)

When the gas springs are to be used in a linked system, make sure to order the "L-version" by adding "-L" after the gas spring code. The "L-version" gas springs are supplied already discharged and without valve, ready for the connection to linked system.

Example: "IGS750-50-L"

Lorsque les ressorts à gaz doivent être utilisés dans un système lié, assurez-vous de commander la « version L » en ajoutant « -L » après le code du ressort à gaz. Les ressorts à gaz « version L » sont fournis déjà déchargés et sans vanne, prêts pour le raccordement au système lié.

Exemple: "IGS750-50-L"

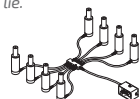

REPAIR KIT / KIT DE RÉPARATION

Gas spring code Code des ressorts à gaz	Repair kit code Code du kit de réparation
IGS150-...	KR/IGS150
IGS250-...	KR/IGS250
IGS500-10 - IGS500-63	KR/IGS500-1
IGS500-80 - IGS500-200	KR/IGS500-2
IGS750-13 - IGS750-50	KR/IGS750-1
IGS750-63 - IGS750-300	KR/IGS750-2
IGS1500-13 - IGS1500-50	KR/IGS1500-1
IGS1500-63 - IGS1500-300	KR/IGS1500-2

Download repair instructions from www.bordignon.com /

Téléchargez les instructions de réparation de www.bordignon.com

FORCE RISE VS. USED STROKE LENGTH CHARTS

GRAP. AUGM. DE LA FORCE VS. COURSE UTILISÉE

The force curves in the charts below are obtained from reference values measured in static conditions. The actual forces generated under use conditions may vary, since they depend on the specific parameters of the application, such as the working speed (cycles per minute).

Les courbes de force dans les tableaux ci-dessous sont obtenues à partir de valeurs de référence mesurées dans des conditions statiques. Les forces réelles générées dans les conditions d'utilisation peuvent varier, car elles dépendent des paramètres spécifiques de l'application, tels que la vitesse de travail (cycles par minute).

IGS150

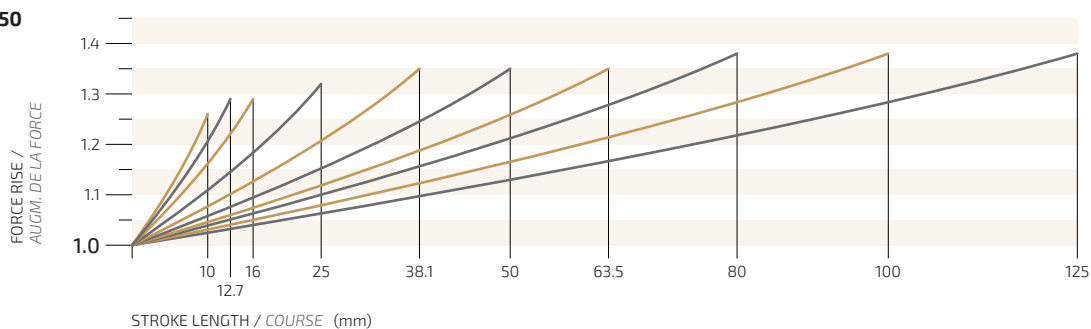

IGS250

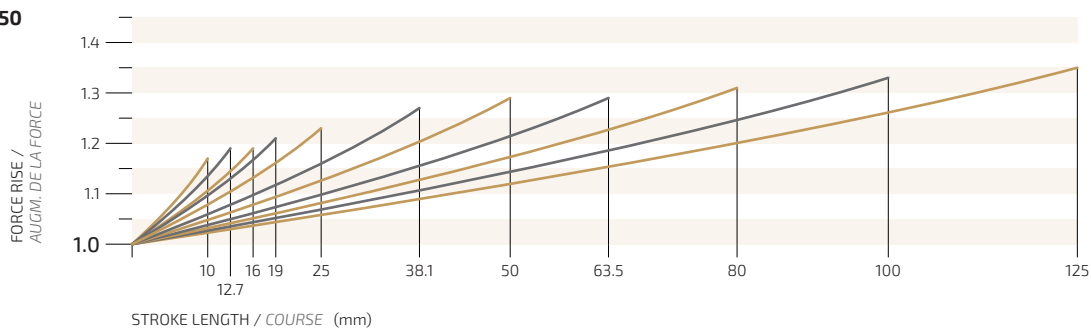

IGS500

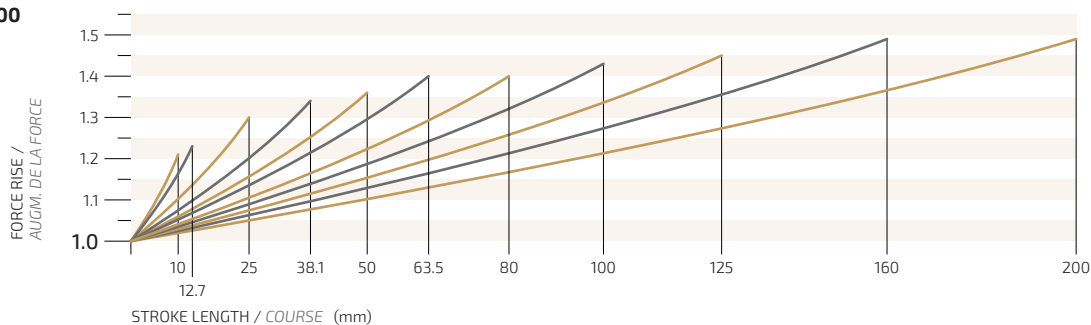

IGS750

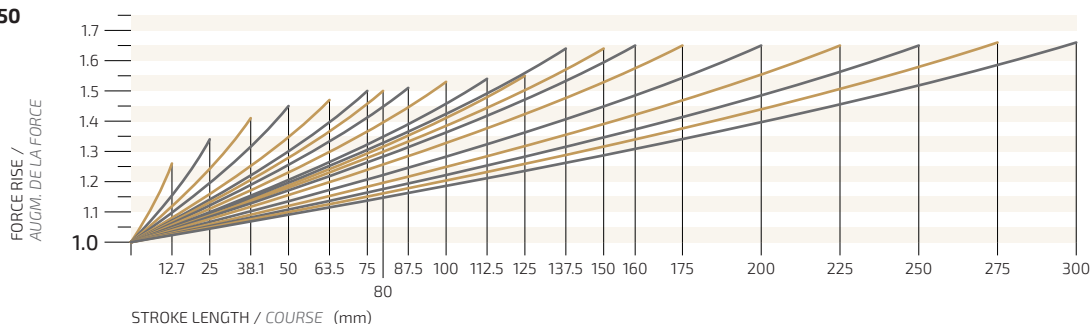

FORCE RISE VS. USED STROKE LENGTH CHARTS

The force curves in the charts below are obtained from reference values measured in static conditions. The actual forces generated under use conditions may vary, since they depend on the specific parameters of the application, such as the working speed (cycles per minute).

GRAP. AUGM. DE LA FORCE VS. COURSE UTILISÉE

Les courbes de force dans les tableaux ci-dessous sont obtenues à partir de valeurs de référence mesurées dans des conditions statiques. Les forces réelles générées dans les conditions d'utilisation peuvent varier, car elles dépendent des paramètres spécifiques de l'application, tels que la vitesse de travail (cycles par minute).

IGS1500

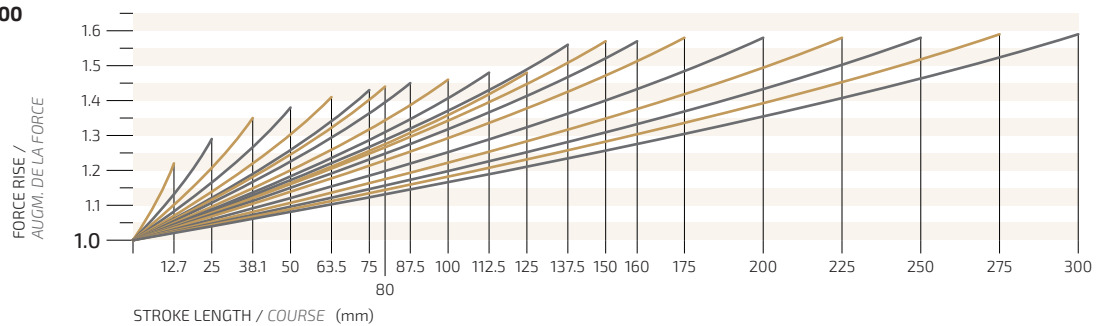



This gas spring series includes the models compliant with automotive standards / La série de ressorts à gaz comprend les modèles conformes aux normes autos

BMW	B2 4006	Nissan	K325, K32C
FCA	075.90.55	PSA	E24.54.815.G
Ford	W-DX35-6203	Renault	EM24.54.700
Mazda	PG23D	Suzuki	SES-K 5404e
MB	B8 3180 220 000 001	VW	39D 878



Technical notes / Notes techniques
Important use instructions in the dedicated catalogue section.
Instructions d'utilisation importantes dans la section dédiée au catalogue.

IGS series nitrogen gas springs feature standard dimensions and forces, as well as several fixing and linking possibilities. With the IGS series nitrogen gas springs, Bordignon now ensures a great interchangeability and a superior reliability. IGS series nitrogen gas springs are self-lubricated.

Les ressorts à gaz de la série IGS présentent des dimensions et des forces standard, ainsi que plusieurs possibilités de fixation et de liaison. Avec les ressorts à gaz azoté de la série IGS, Bordignon assure désormais une grande interchangeabilité et une fiabilité supérieure. Les ressorts à gaz de la série IGS sont autolubrifiants.

Piston rod surface roughness Ra ~ 0.02 µm
surface µ-hardness ~ 800 HV

Tige de piston rugosité de surface Ra ~ 0.02 µm
dureté µ surface ~ 800 HV

Wiper ring
Racleur de tige

Rod guide
Guide-tige

Rod seal
Joint de tige

Single-piece body construction
Construction du corps monobloc

Non-return valve
Clapet anti-retour

O-ring seal
Joint torique

G1/8 side port (charging port)
(charge with nitrogen N₂ only)
Port latéral G1/8 (port de charge)
(charge avec de l'azote N₂ uniquement)

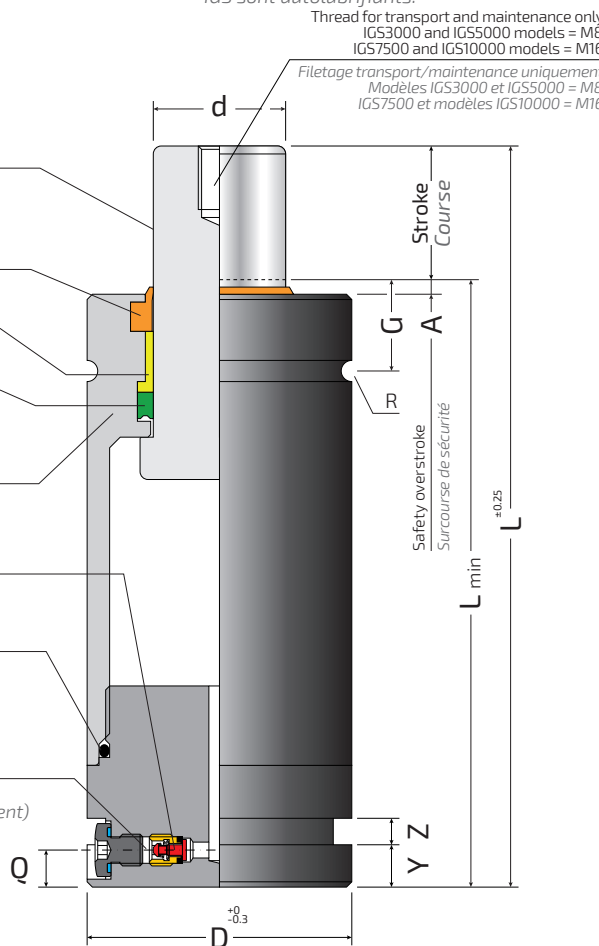

Fixing possibilities / Possibilités de fixation

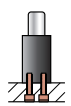

at the base with screws
à la base avec des vis

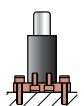

with base-plate
avec plaque de base
BF, BFA, BFB, BFR

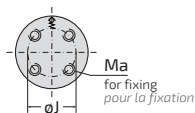

**IGS3000, IGS5000,
IGS7500, IGS10000**

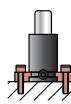

with half-flanges
avec demi-brides
SF, SFA

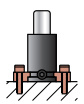

with foot brackets
avec repose-pieds
ST, STA

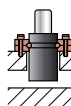

with collar flange
avec bride de collier
FL, FLQ

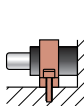

with front support
avec support frontal
FT, FTA

GAS SPRING BASE / BASE DU RESSORT À GAZ

LINKING TO OPEN SYSTEM/ LIAISON AU SYSTÈME OUVERT

	IGS3000-IGS10000 (G1/8 side port / Port latéral G1/8)		
Hoses Tuyaux	ATM	ATN	AT
Gas spring-hose fittings Raccords ressort de gaz - tuyau	ARM	ARN	AR

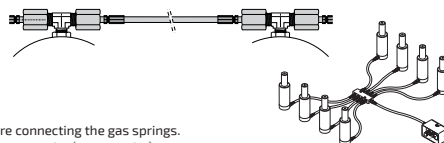

ATTENTION! Follow the instructions in the "LINKED SYSTEM" section before connecting the gas springs.
ATTENTION! Suivez les instructions de la section « SYSTÈME LIÉ » avant de connecter les ressorts à gaz.

SAFETY PROTECTIONS / PROTECTIONS DE SÉCURITÉ



**UNCONTROLLED
RETURN SPEED /
VITESSE DE RETOUR
INCONTRÔLÉE**



**OVERSTROKE /
SURCOURSE**



**OVERPRESSURE /
SURPRESSION**

Model Modèle	MAX Stroke 100% usable MAX course 100% utilisable		Lmin mm	L mm	D mm	d mm	G mm	A mm	R mm	Y mm	Z mm	Q mm	Ma	J mm	bar (MPa)	daN	daN	Cycles per minute MAX Cycles par minute MAX	Gas volume Gaz volume dm ³	Weight Poids kg
	12.7	132.3																		
IGS3000-13	12.7	132.3	145														3650	235	0.24	5.15
25	25	145	170														3850	120	0.30	5.58
38	38.1	158.1	196.2														4050	80	0.37	5.97
50	50	170	220														4200	60	0.43	6.33
63	63.5	183.5	247														4300	50	0.51	6.76
75	75	195	270														4400	40	0.57	7.10
80	80	200	280														4400	40	0.59	7.25
88	87.5	207.5	295														4450	35	0.63	7.49
100	100	220	320														4500	30	0.70	7.83
113	112.5	232.5	345	95	50	24	3	2.5	8	5	10.5	M8 x 13 (4x)	60	150 (15.0)	2945	4550	27	0.76	8.21	
125	125	245	370														4600	25	0.83	8.59
138	137.5	257.5	395														4900	22	0.80	9.72
150	150	270	420														4900	20	0.87	10.10
160	160	280	440														4900	19	0.92	10.42
175	175	295	470														4950	17	0.99	10.87
200	200	320	520														4950	15	1.13	11.64
225	225	345	570														5000	13	1.26	12.40
250	250	370	620														5000	12	1.39	13.16
275	275	395	670														5000	11	1.53	13.92
300	300	420	720														5000	10	1.66	14.70
IGS5000-25	25	165	190														6600	120	0.48	10.78
38	38.1	178.1	216.2														7000	80	0.58	11.52
50	50	190	240														7300	60	0.67	12.20
63	63.5	203.5	267														7600	50	0.77	13.00
75	75	215	290														7700	40	0.85	13.62
80	80	220	300														7800	40	0.89	13.91
88	87.5	227.5	315														7900	35	0.95	14.27
100	100	240	340														8000	30	1.04	14.98
113	112.5	252.5	365														8200	27	1.14	15.70
125	125	265	390	120	65	25.5	3	2.5	8	5	10.5	M10 x 16 (4x)	80	150 (15.0)	4980	8300	25	1.23	16.41	
138	137.5	277.5	415														8900	22	1.19	18.18
150	150	290	440														8900	20	1.29	18.88
160	160	300	460														9000	19	1.36	19.45
175	175	315	490														9000	17	1.47	20.30
200	200	340	540														9100	15	1.66	21.72
225	225	365	590														9200	13	1.85	23.14
250	250	390	640														9200	12	2.04	24.56
275	275	415	690														9300	11	2.23	25.98
300	300	440	740														9300	10	2.42	27.40
IGS7500-25	25	180	205														9300	120	1.15	15.72
38	38.1	193.1	231.2														9700	80	1.32	16.73
50	50	205	255														10000	60	1.47	17.69
63	63.5	218.5	282														10300	50	1.64	18.74
75	75	230	305														10500	40	1.79	19.65
80	80	235	315														10600	40	1.86	20.04
88	87.5	242.5	330														10700	35	1.95	20.52
100	100	255	355														10900	30	2.11	21.55
113	112.5	267.5	380														11000	27	2.27	22.48
125	125	280	405	150	80	27.5	3	2.5	8	5	10.5	M10 x 16 (4x)	100	150 (15.0)	7540	11200	25	2.43	23.52	
138	137.5	292.5	430														11800	22	2.33	26.50
150	150	305	455														11900	20	2.49	27.53
160	160	315	475														12000	19	2.62	28.33
175	175	330	505														12000	17	2.82	29.49
200	200	355	555														12200	15	3.14	31.47
225	225	380	605														12300	13	3.46	33.43
250	250	405	655														12400	12	3.78	35.39
275	275	430	705														12500	11	4.10	37.36
300	300	455	755														12600	10	4.43	39.33
IGS10000-25	25	185	210														12900	120	1.87	28.39
38	38.1	198.1	236.2														13300	80	2.16	29.90
50	50	210	260														13700	60	2.42	31.33
63	63.5	223.5	287														14000	50	2.72	32.92
80	80	240	320														14300	40	3.09	34.87
100	100	260	360	195	95	33.5	3	2.5	8	8	15	M12 x 18 (4x)	120	150 (15.0)	10600	14600	30	3.53	37.22	
125	125	285	410														14900	25	4.08	40.17
160	160	320	480														15900	19	4.23	49.23
200	200	360	560														16100	15	5.12	53.95
250	250	410	660														16300	12	6.22	59.84
300	300	460	760														17200	10	6.62	71.32

CE The gas spring models for which the CE symbol is indicated have an internal gas volume > 1 litre (1 dm³). They fall into Category II of the 2014/68/EU Pressure Equipment Directive (PED).
 All the other gas spring models in this table are in accordance with Article 4.3 of the 2014/68/EU Pressure Equipment Directive (PED).
 Les modèles à ressort à gaz pour lesquels le symbole CE est indiqué ont un volume de gaz interne > 1 litre (1 dm³). Ils entrent dans la catégorie II de la directive 2014/68/UE sur les équipements sous pression (PED).
 Tous les autres modèles de ressorts à gaz de ce tableau sont conformes à l'article 4.3 de la directive 2014/68/UE sur les équipements sous pression (PED).

"L-VERSION" (FOR LINKED SYSTEM) / « VERSION L » (POUR SYSTÈME LIÉ)

When the gas springs are to be used in a linked system, make sure to order the "L-version" by adding "-L" after the gas spring code. The "L-version" gas springs are supplied already discharged and without valve, ready for the connection to linked system.

Example: "IGS5000-50-L"

Lorsque les ressorts à gaz doivent être utilisés dans un système lié, assurez-vous de commander la « version L » en ajoutant « -L » après le code du ressort à gaz. Les ressorts à gaz « version L » sont fournis déjà déchargés et sans vanne, prêts pour le raccordement au système lié.

Exemple: "IGS5000-50-L"

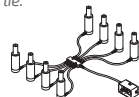

REPAIR KIT / KIT DE RÉPARATION

Gas spring code Code des ressorts à gaz	Repair kit code Code du kit de réparation
IGS3000-13 - IGS3000-50	KR/IGS3000-1
IGS3000-63 - IGS3000-300	KR/IGS3000-2
IGS5000-25, IGS5000-38	KR/IGS5000-1
IGS5000-50 - IGS5000-300	KR/IGS5000-2
IGS7500-25, IGS7500-38	KR/IGS7500-1
IGS7500-50 - IGS7500-300	KR/IGS7500-2
IGS10000-25, IGS10000-38	KR/IGS10000-1
IGS10000-50 - IGS10000-300	KR/IGS10000-2

Download repair instructions from www.bordignon.com /
 Téléchargez les instructions de réparation de www.bordignon.com

FORCE RISE VS. USED STROKE LENGTH CHARTS

GRAP. AUGM. DE LA FORCE VS. COURSE UTILISÉE

The force curves in the charts below are obtained from reference values measured in static conditions. The actual forces generated under use conditions may vary, since they depend on the specific parameters of the application, such as the working speed (cycles per minute).

Les courbes de force dans les tableaux ci-dessous sont obtenues à partir de valeurs de référence mesurées dans des conditions statiques. Les forces réelles générées dans les conditions d'utilisation peuvent varier, car elles dépendent des paramètres spécifiques de l'application, tels que la vitesse de travail (cycles par minute).

IGS3000

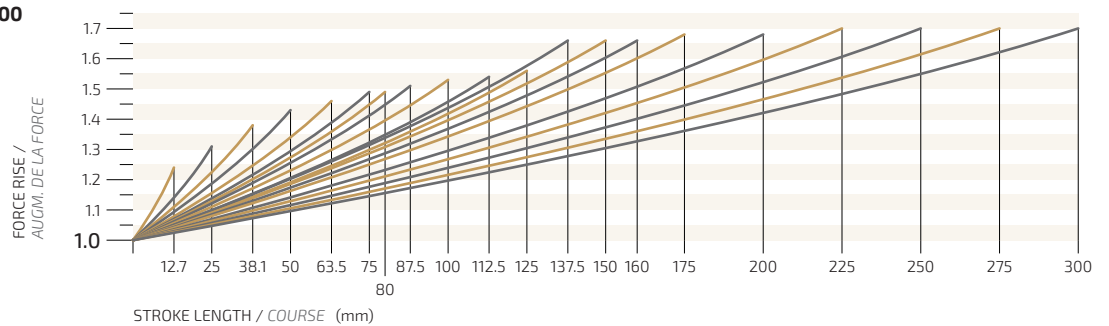

IGS5000

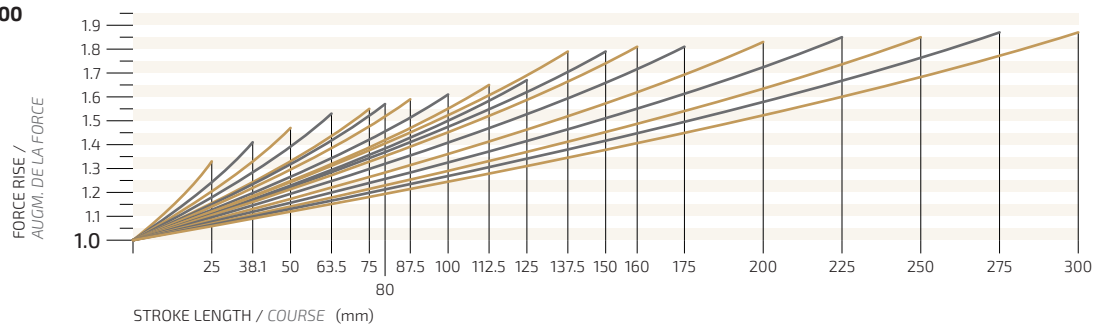

IGS7500

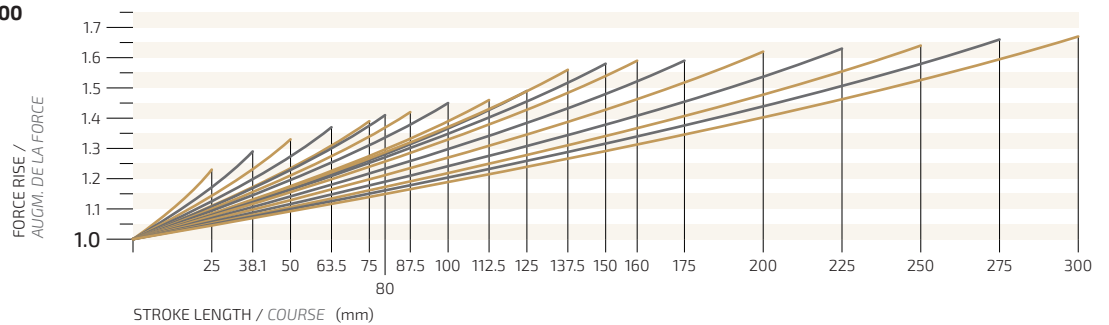

IGS10000

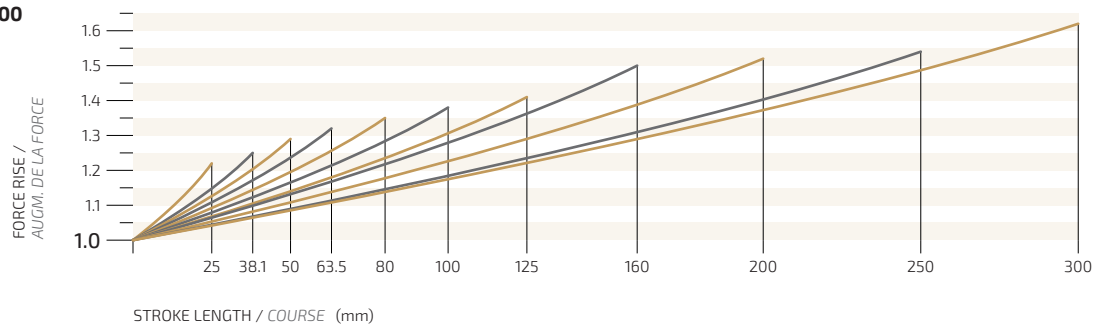



500



Technical notes / Notes techniques
 Important use instructions in the dedicated catalogue section.
 Instructions d'utilisation importantes dans la section dédiée au catalogue.

LGS series nitrogen gas springs feature standard forces and compact length, as well as several fixing and linking possibilities. With the LGS series nitrogen gas springs, Bordignon now ensures a great interchangeability and a superior reliability. LGS series nitrogen gas springs are self-lubricated.

Les ressorts à gaz de la série LGS se caractérisent par des forces standard et une longueur compacte, ainsi que par plusieurs possibilités de fixation et de liaison. Avec les ressorts à gaz de la série LGS, Bordignon assure désormais une grande interchangeabilité et une fiabilité supérieure. Les ressorts à gaz de la série LGS sont autolubrifiants.

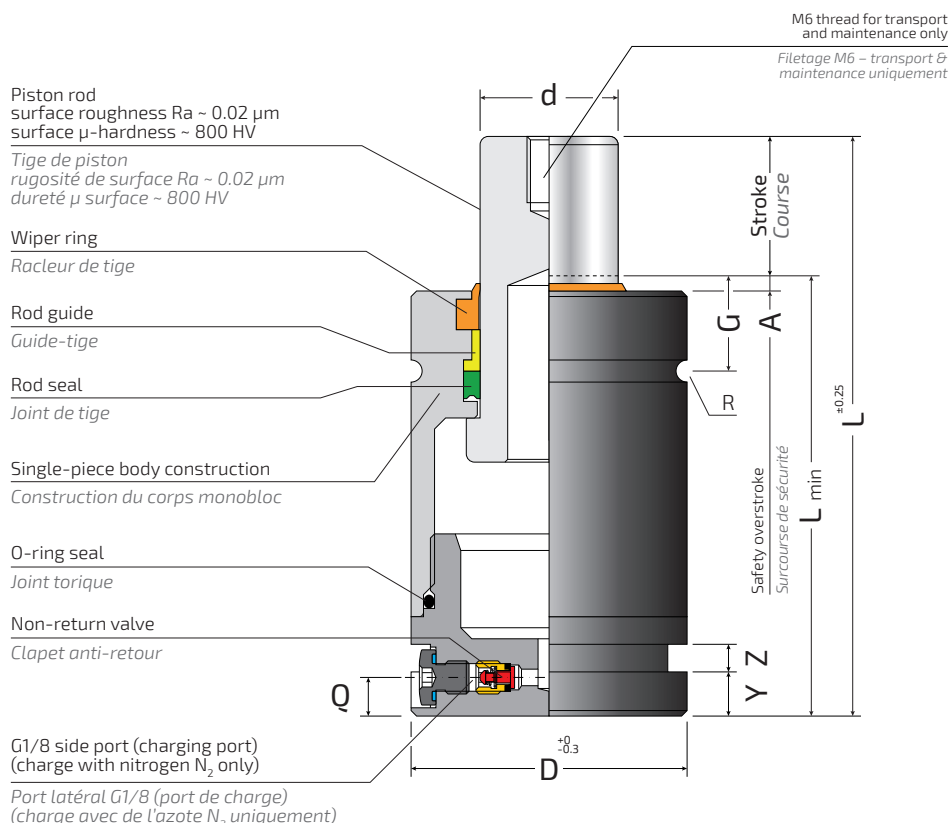

Fixing possibilities / Possibilités de fixation

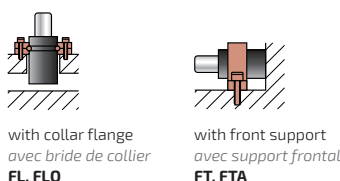
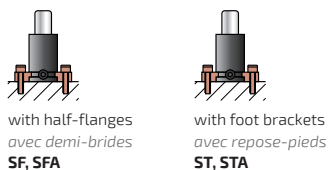
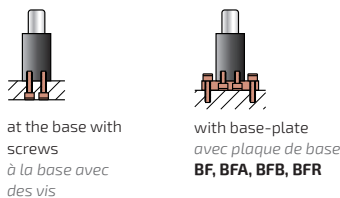

GAS SPRING BASE / BASE DU RESSORT À GAZ

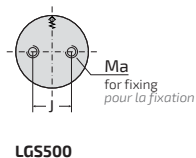

LINKING TO OPEN SYSTEM / LIAISON AU SYSTÈME OUVERT

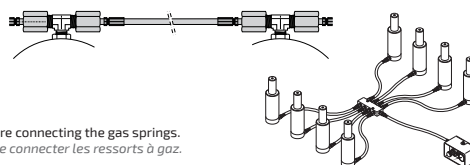

	LGS500 (G1/8 side port / Port latéral G1/8)		
Hoses / Tuyaux	ATM	ATN	AT
Gas spring-hose fittings / Raccords ressort de gaz – tuyau	ARM	ARN	AR



ATTENTION! Follow the instructions in the "LINKED SYSTEM" section before connecting the gas springs.
ATTENTION! Suivez les instructions de la section « SYSTÈME LIÉ » avant de connecter les ressorts à gaz.

SAFETY PROTECTIONS / PROTECTIONS DE SÉCURITÉ



Model Modèle	MAX Stroke 100% usable MAX course 100% utilisable mm	L min mm	L mm	D mm	d mm	G mm	A mm	R mm	Y mm	Z mm	Q mm	Ma	J mm	bar (MPa)	 daN	 daN	Cycles per minute MAX Cycles par minute MAX	Gas volume Gaz volume dm ³	Weight Poids kg
LGS500-80	80	130	210	45	20	15.5	2	1	4	4	10.5	MB x 13 (2x)	20	150 (15.0)	470	700	40	0.097	0.89

All the gas spring models in this table are in accordance with Article 4.3 of the 2014/68/EU Pressure Equipment Directive (PED)

Tous les modèles de ressorts à gaz de ce tableau sont conformes à l'article 4.3 de la directive 2014/68/UE sur les équipements sous pression (PED)

"L-VERSION" (FOR LINKED SYSTEM) / « VERSION L » (POUR SYSTÈME LIÉ)

When the gas springs are to be used in a linked system, make sure to order the "L-version" by adding "-L" after the gas spring code. The "L-version" gas springs are supplied already discharged and without valve, ready for the connection to linked system.

Example: "LGS500-80-L"

Lorsque les ressorts à gaz doivent être utilisés dans un système lié, assurez-vous de commander la « version L » en ajoutant « -L » après le code du ressort à gaz. Les ressorts à gaz « version L » sont fournis déjà déchargés et sans vanne, prêts pour le raccordement au système lié.

Exemple: "LGS500-80-L"

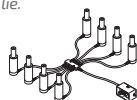

REPAIR KIT / KIT DE RÉPARATION

Gas spring code Code des ressorts à gaz	Repair kit code Code du kit de réparation
LGS500-...	KR/LGS500

Download repair instructions from www.bordignon.com /

Téléchargez les instructions de réparation de www.bordignon.com

FORCE RISE VS. USED STROKE LENGTH CHARTS

GRAP. AUGM. DE LA FORCE VS. COURSE UTILISÉE

The force curves in the charts below are obtained from reference values measured in static conditions. The actual forces generated under use conditions may vary, since they depend on the specific parameters of the application, such as the working speed (cycles per minute).

Les courbes de force dans les tableaux ci-dessous sont obtenues à partir de valeurs de référence mesurées dans des conditions statiques. Les forces réelles générées dans les conditions d'utilisation peuvent varier, car elles dépendent des paramètres spécifiques de l'application, tels que la vitesse de travail (cycles par minute).

LGS500

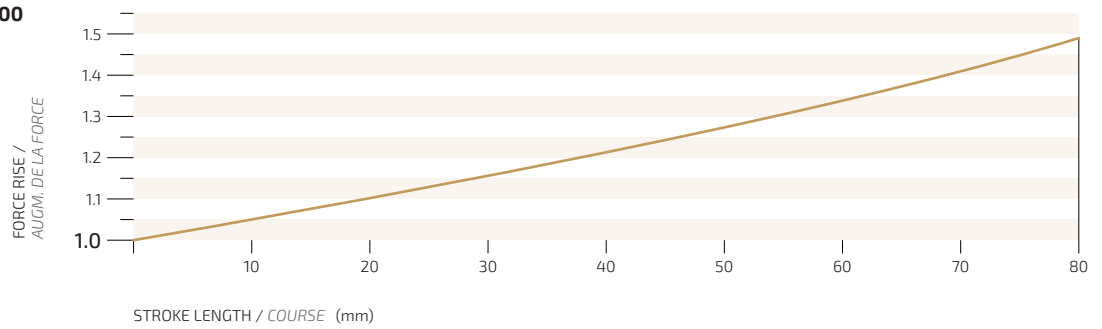

BMW	B2 4008
FCA	075.90.65
VW	39D 838

300~1500



PGS series nitrogen gas springs feature standard dimensions and enhanced forces, as well as several fixing and linking possibilities. PGS series nitrogen gas springs are self-lubricated.

Les ressorts à gaz de la série PGS se caractérisent par des dimensions standard et des forces accrues, ainsi que par plusieurs possibilités de fixation et de liaison. Les ressorts à gaz de la série PGS sont autolubrifiants.

Technical notes / Notes techniques
Important use instructions in the dedicated catalogue section.
Instructions d'utilisation importantes dans la section dédiée au catalogue.

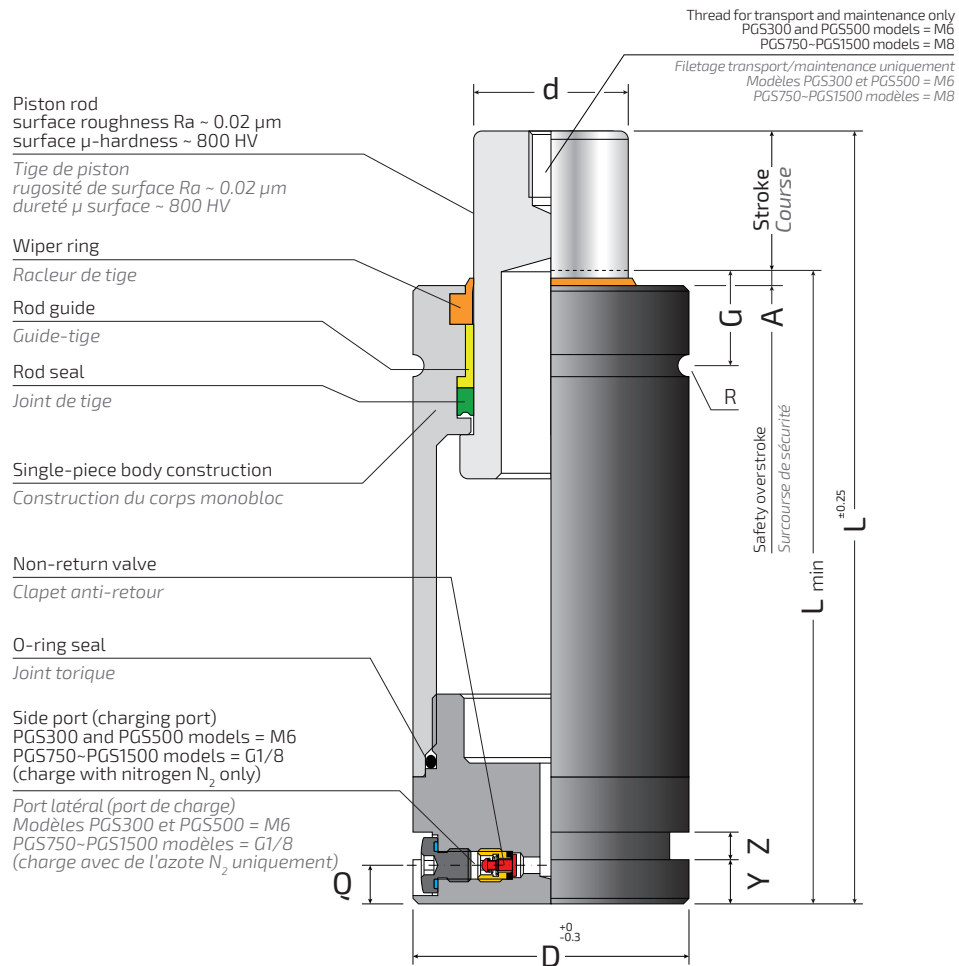

Fixing possibilities / Possibilités de fixation

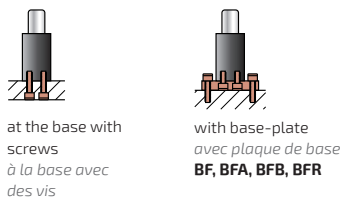

GAS SPRING BASE / BASE DU RESSORT À GAZ

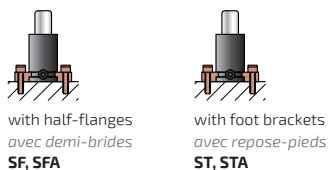
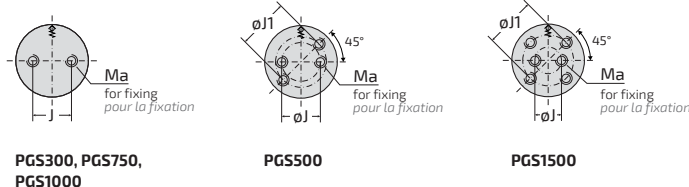

LINKING TO OPEN SYSTEM / LIAISON AU SYSTÈME OUVERT

	PGS300-PGS500 (M6 side port / Port latéral M6)		PGS750-PGS1500 (G1/8 side port / Port latéral G1/8)		
Hoses Tuyaux	ATM	ATNM	ATM	ATN	AT
Gas spring-hose fittings Raccords ressort de gaz - tuyau	ARM	ARNM	ARM	ARN	AR

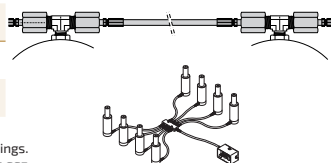

ATTENTION! Follow the instructions in the "LINKED SYSTEM" section before connecting the gas springs.
ATTENTION! Suivez les instructions de la section « SYSTÈME LIÉ » avant de connecter les ressorts à gaz.

SAFETY PROTECTIONS / PROTECTIONS DE SÉCURITÉ

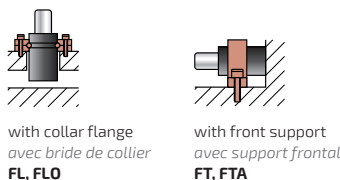

UNCONTROLLED RETURN SPEED /
VITESSE DE RETOUR INCONTRÔLÉE



OVERSTROKE /
SURCOURSE



OVERPRESSURE /
SURPRESSION

Model Modèle	MAX Stroke 100% usable MAX course 100% utilisable		Lmin mm	L mm	D mm	d mm	G mm	A mm	R mm	Y mm	Z mm	Q mm	Ma	J mm	J1 mm	bar (MPa)	daN	daN	daN	Cycles per minute MAX	Gas volume	Weight Poids kg
	Cycles par minute MAX	Gaz volume dm ³																				
PGS300-10	10	60	70																390	300	0.013	0.25
13	13	62.7	75.7																400	230	0.015	0.26
16	16	66	82																410	190	0.016	0.28
25	25	75	100																430	120	0.022	0.29
38	38	88	126	32	16	12.5	2	1	4	4	6	M6 x 11 (2x)	18	-	150 (15.0)	300		450	80	0.029	0.35	
50	50	100	150															460	60	0.036	0.39	
63	63	113.5	176.5															470	50	0.043	0.44	
80	80	130	210															480	40	0.051	0.50	
100	100	150	250															490	30	0.062	0.58	
125	125	175	300															500	25	0.074	0.69	
PGS500-10	10	60	70																610	300	0.021	0.35
13	13	62.7	75.7																640	230	0.021	0.37
16	16	66	82																650	190	0.025	0.38
19	19	69	88																670	160	0.026	0.40
25	25	75	100																690	120	0.031	0.43
38	38	88	126	38	20	12.5	2	1	4	4	6	M6 x 9 (J: 2x) (J1: 2x)	18	25	150 (15.0)	470		730	80	0.041	0.51	
50	50	100	150															760	60	0.049	0.57	
63	63	113.5	176.5															770	50	0.060	0.65	
80	80	130	210															790	40	0.073	0.73	
100	100	150	250															810	30	0.087	0.85	
125	125	175	300															820	25	0.106	0.99	
PGS750-10	10	95	105																980	300	0.029	0.79
13	13	98	111																1000	230	0.034	0.83
25	25	110	135																1080	120	0.050	0.91
38	38	123	161																1120	80	0.069	0.99
50	50	135	185																1160	60	0.082	1.07
63	63	148	211																1180	50	0.100	1.14
75	75	160	235																1200	40	0.115	1.21
80	80	165	245	45	25	16.5	2	1	4	4	10.5	M8 x 13 (2x)	20	-	150 (15.0)	740		1200	40	0.122	1.24	
100	100	185	285																1210	30	0.149	1.35
125	125	210	335																1260	25	0.174	1.52
150	150	235	385																1270	20	0.206	1.76
160	160	245	405																1270	19	0.220	1.84
175	175	260	435																1270	17	0.241	1.90
200	200	285	485																1280	15	0.270	2.00
PGS1000-13	13	108	121																1210	230	0.05	1.10
25	25	120	145																1320	120	0.07	1.20
38	38	133	171																1390	80	0.09	1.31
50	50	145	195																1440	60	0.10	1.40
63	63	158	221																1460	50	0.13	1.51
75	75	170	245																1490	40	0.14	1.61
80	80	175	255																1490	40	0.15	1.66
100	100	195	295	50	28	17.5	3	2	8	5	10.5	M8 x 13 (2x)	20	-	150 (15.0)	920		1540	30	0.18	1.83	
125	125	220	345																1560	25	0.22	2.03
150	150	245	395																1570	20	0.26	2.39
160	160	255	415																1570	19	0.28	2.47
175	175	270	445																1610	17	0.29	2.60
200	200	295	495																1610	15	0.33	2.80
250	250	345	595																1610	12	0.41	3.15
300	300	395	695																1640	10	0.48	3.63
PGS1500-13	13	108	121																1990	230	0.09	1.98
25	25	120	145																2110	120	0.13	2.16
38	38	133	171																2260	80	0.15	2.32
50	50	145	195																2280	60	0.19	2.48
63	63	158	221																2360	50	0.22	2.65
75	75	170	245																2400	40	0.26	2.80
80	80	175	255																2400	40	0.27	2.86
100	100	195	295	63	36	19	3	2	8	5	10.5	M8 x 13 (J: 2x) (J1: 4x)	20	40	150 (15.0)	1530		2450	30	0.33	3.12	
125	125	220	345																2480	25	0.40	3.43
150	150	245	395																2520	20	0.46	4.05
160	160	255	415																2520	19	0.49	4.18
175	175	270	445																2560	17	0.52	4.37
200	200	295	495																2570	15	0.59	4.69
250	250	345	595																2620	12	0.71	5.30
300	300	395	695																2620	10	0.86	5.96

All the gas spring models in this table are in accordance with Article 4.3 of the 2014/68/EU Pressure Equipment Directive (PED)

Tous les modèles de ressorts à gaz de ce tableau sont conformes à l'article 4.3 de la directive 2014/68/UE sur les équipements sous pression (PED)

"L-VERSION" (FOR LINKED SYSTEM) / « VERSION L » (POUR SYSTÈME LIÉ)

When the gas springs are to be used in a linked system, make sure to order the "L-version" by adding "-L" after the gas spring code. The "L-version" gas springs are supplied already discharged and without valve, ready for the connection to linked system.

Example: "PGS1000-50-L"

Lorsque les ressorts à gaz doivent être utilisés dans un système lié, assurez-vous de commander la « version L » en ajoutant « -L » après le code du ressort à gaz. Les ressorts à gaz « version L » sont fournis déjà déchargés et sans vanne, prêts pour le raccordement au système lié.

Exemple: "PGS1000-50-L"

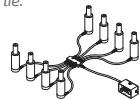

REPAIR KIT / KIT DE RÉPARATION

Gas spring code Code des ressorts à gaz	Repair kit code Code du kit de réparation
PGS300-...	KR/PGS300
PGS500-...	KR/PGS500
PGS750-10 - PGS750-125	KR/PGS750-1
PGS750-150 - PGS750-200	KR/PGS750-2
PGS1000-13 - PGS1000-125	KR/PGS1000-1
PGS1000-150 - PGS1000-300	KR/PGS1000-2
PGS1500-13 - PGS1500-125	KR/PGS1500-1
PGS1500-150 - PGS1500-300	KR/PGS1500-2

Download repair instructions from www.bordignon.com /

Téléchargez les instructions de réparation de www.bordignon.com

FORCE RISE VS. USED STROKE LENGTH CHARTS

GRAP. AUGM. DE LA FORCE VS. COURSE UTILISÉE

The force curves in the charts below are obtained from reference values measured in static conditions. The actual forces generated under use conditions may vary, since they depend on the specific parameters of the application, such as the working speed (cycles per minute).

Les courbes de force dans les tableaux ci-dessous sont obtenues à partir de valeurs de référence mesurées dans des conditions statiques. Les forces réelles générées dans les conditions d'utilisation peuvent varier, car elles dépendent des paramètres spécifiques de l'application, tels que la vitesse de travail (cycles par minute).

PGS300

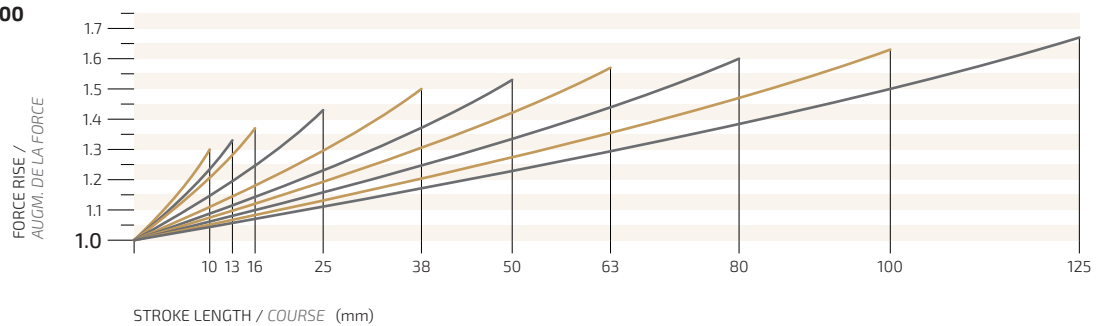

PGS500

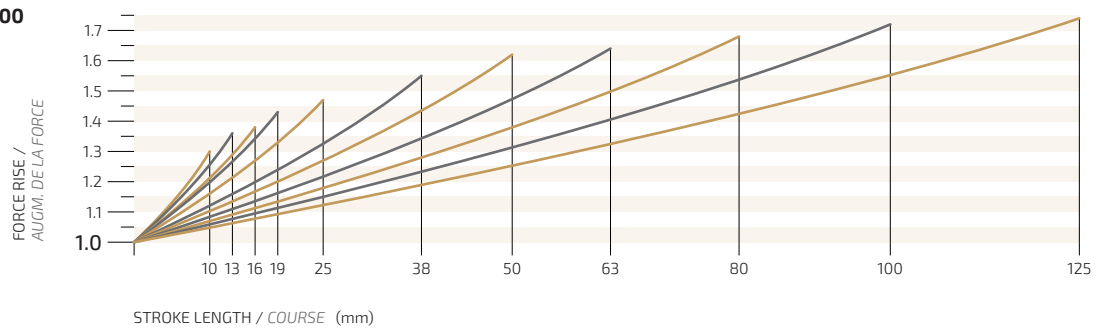

PGS750

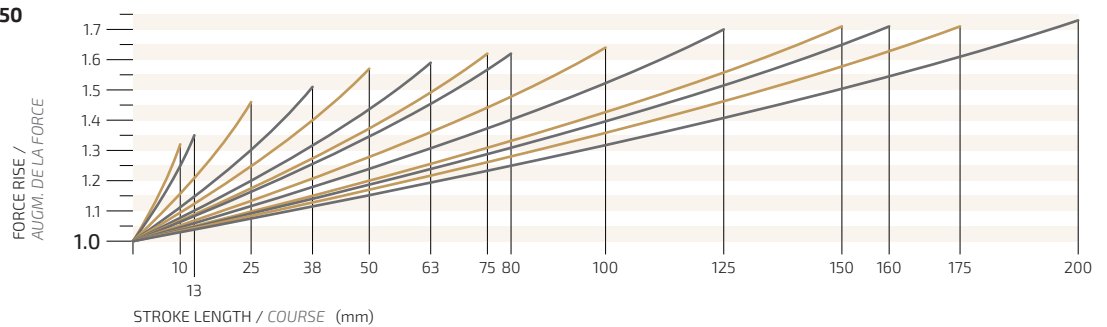

PGS1000

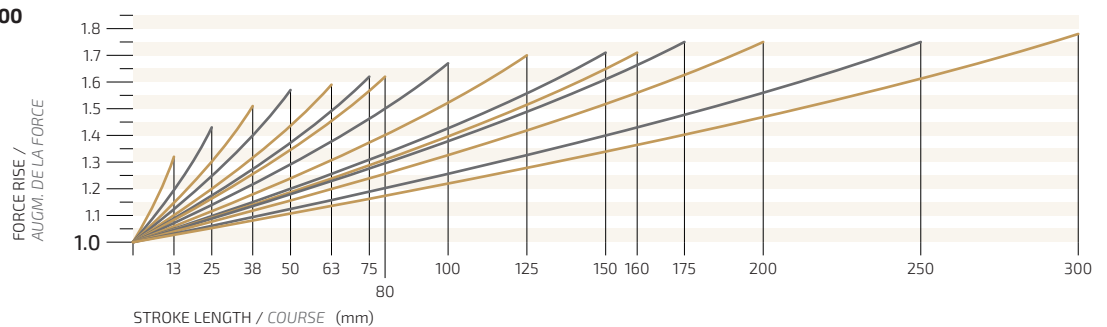

FORCE RISE VS. USED STROKE LENGTH CHARTS

The force curves in the charts below are obtained from reference values measured in static conditions. The actual forces generated under use conditions may vary, since they depend on the specific parameters of the application, such as the working speed (cycles per minute).

GRAP. AUGM. DE LA FORCE VS. COURSE UTILISÉE

Les courbes de force dans les tableaux ci-dessous sont obtenues à partir de valeurs de référence mesurées dans des conditions statiques. Les forces réelles générées dans les conditions d'utilisation peuvent varier, car elles dépendent des paramètres spécifiques de l'application, tels que la vitesse de travail (cycles par minute).

PGS1500

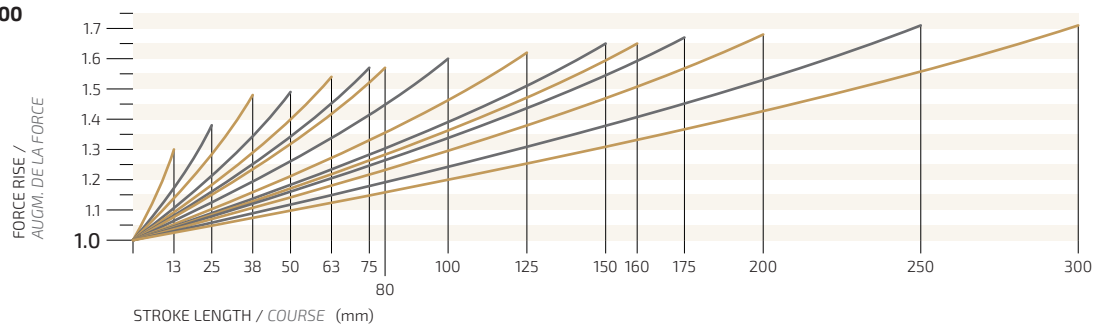

PGS



ISO 11901-4 VDI 3003 Part 4

This gas spring series includes the models compliant with automotive standards / La série de ressorts à gaz comprend les modèles conformes aux normes autos

BMW	B2 4008
FCA	075.90.65
VW	39D 838

2400~20000



PGS series nitrogen gas springs feature standard dimensions and enhanced forces, as well as several fixing and linking possibilities. PGS series nitrogen gas springs are self-lubricated.

Les ressorts à gaz de la série PGS se caractérisent par des dimensions standard et des forces accrues, ainsi que par plusieurs possibilités de fixation et de liaison. Les ressorts à gaz de la série PGS sont autolubrifiants.

Technical notes / Notes techniques
Important use instructions in the dedicated catalogue section. Instructions d'utilisation importantes dans la section dédiée au catalogue.

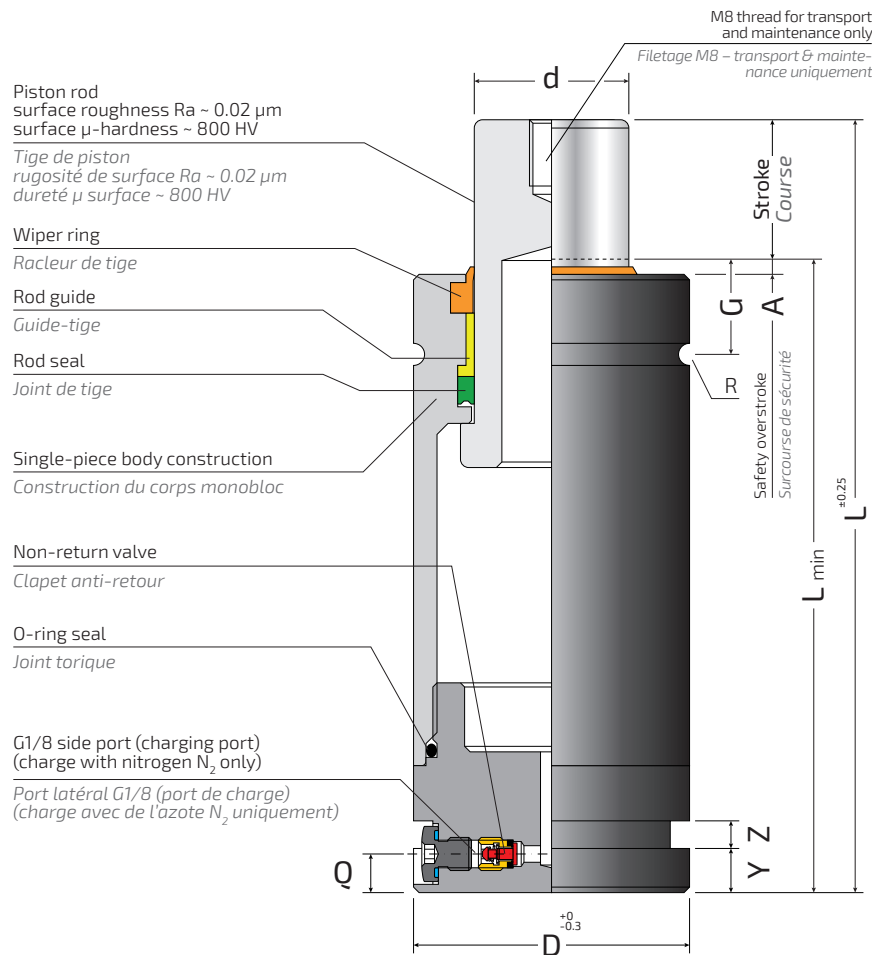

Fixing possibilities / Possibilités de fixation

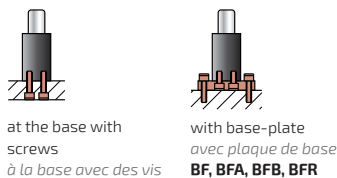

GAS SPRING BASE / BASE DU RESSORT À GAZ

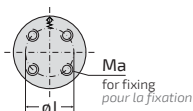

PGS2400, PGS4200, PGS6600, PGS9500, PGS20000

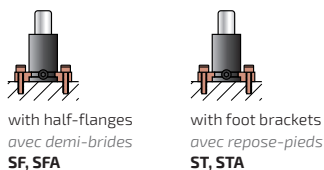

LINKING TO OPEN SYSTEM / LIAISON AU SYSTÈME OUVERT

	PGS2400~PGS20000 (G1/8 side port / Port latéral G1/8)		
Hoses Tuyaux	ATM	ATN	AT
Gas spring-hose fittings Raccords ressort de gaz – tuyau	ARM	ARN	AR

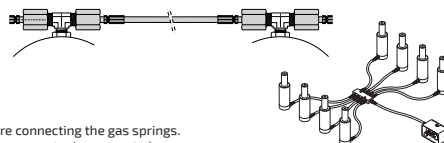

ATTENTION! Follow the instructions in the "LINKED SYSTEM" section before connecting the gas springs. ATTENTION! Suivez les instructions de la section « SYSTÈME LIÉ » avant de connecter les ressorts à gaz.

SAFETY PROTECTIONS / PROTECTIONS DE SÉCURITÉ

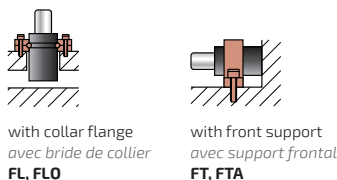

UNCONTROLLED RETURN SPEED / VITESSE DE RETOUR INCONTRÔLÉE



OVERSTROKE / SURCOURSE



OVERPRESSURE / SURPRESSION

PGS 2400~20000

AUTOMOTIVE LINE

Model Modèle	MAX Stroke 100% usable MAX course 100% utilisable		Lmin mm	L mm	D mm	d mm	G mm	A mm	R mm	Y mm	Z mm	Q mm	Ma	J mm	bar (MPa)	daN	daN	Cycles per minute MAX Cycles par minute MAX	Gas volume Gaz volume dm ³	Weight Poids kg	
	mm	mm																			
PGS2400 -25	25	135	160															4050	120	0.11	3.11
	38	38	148															4080	80	0.17	3.34
	50	50	160															4130	60	0.22	3.55
	63	63	173															4130	50	0.28	3.78
	75	75	185															4170	40	0.32	3.98
	80	80	190															4170	40	0.34	4.06
	100	100	210															4200	30	0.42	4.40
	125	125	235	75	45	21	3	2.5	8	5	10.5	M8 x 13 (4x)	40	150 (15.0)	2385			4220	25	0.53	4.84
	150	150	260															4220	20	0.63	5.71
	160	160	270															4220	19	0.67	5.88
	175	175	285															4250	17	0.73	6.14
	200	200	310															4250	15	0.83	6.57
	250	CE	250															4250	12	1.04	7.44
	275	CE	275															4250	11	1.14	7.67
	300	CE	300															4250	10	1.25	8.30
PGS4200 -25	25	145	170															5600	120	0.42	5.31
	38	38	158															5850	80	0.53	5.68
	50	50	170															6110	60	0.60	6.03
	63	63	183															6280	50	0.69	6.43
	75	75	195															6490	40	0.75	6.76
	80	80	200															6490	40	0.80	6.90
	100	100	220															6740	30	0.92	7.45
	125	CE	125	95	60	24	3	2.5	8	5	10.5	M8 x 13 (4x)	60	150 (15.0)	4240			6870	25	1.10	8.18
	150	CE	150															7000	20	1.27	9.62
	160	CE	160															7080	19	1.33	9.92
	175	CE	175															7210	17	1.40	10.35
	200	CE	200															7250	15	1.59	11.09
	250	CE	250															7340	12	1.94	12.54
	300	CE	300															7460	10	2.26	14.00
PGS6600 -25	25	165	190															8750	120	0.66	10.27
	38	38	178															9150	80	0.83	10.97
	50	50	190															9610	60	0.92	11.62
	63	CE	63															9880	50	1.06	12.38
	75	CE	75															10010	40	1.22	12.97
	80	CE	80															10140	40	1.26	13.25
	100	CE	100															10410	30	1.48	14.27
	125	CE	125	120	75	25.5	3	2.5	8	5	10.5	M10 x 16 (4x)	80	150 (15.0)	6630			10610	25	1.77	15.63
	150	CE	150															10870	20	2.01	17.98
	160	CE	160															10940	19	2.12	18.52
	175	CE	175															11070	17	2.27	19.33
	200	CE	200															11270	15	2.50	20.68
	250	CE	250															11400	12	3.06	23.39
	300	CE	300															11600	10	3.57	26.09
PGS9500 -25	CE	25	180															12400	120	1.03	14.97
	38	CE	38															13070	80	1.23	15.93
	50	CE	50															13640	60	1.38	16.84
	63	CE	63															13930	50	1.63	17.85
	75	CE	75															14210	40	1.82	18.71
	80	CE	80															14210	40	1.94	19.09
	100	CE	100															14690	30	2.23	20.53
	125	CE	125	150	90	27.5	3	2.5	8	5	10.5	M10 x 16 (4x)	100	150 (15.0)	9540			15170	25	2.58	22.40
	150	CE	150															15360	20	3.01	26.22
	160	CE	160															15450	19	3.17	26.98
	175	CE	175															15650	17	3.38	28.09
	200	CE	200															15740	15	3.82	29.97
	250	CE	250															16030	12	4.61	33.71
	300	CE	300															16220	10	5.41	37.46
PGS20000 -25	CE	25	185															26280	120	1.99	27.04
	38	CE	38															27870	80	2.35	28.48
	50	CE	50															29070	60	2.69	29.83
	63	CE	63															30060	50	3.08	31.35
	75	CE	75															30660	40	3.48	31.90
	80	CE	80															31260	40	3.55	33.21
	100	CE	100															31860	30	4.25	35.45
	125	CE	125	195	130	33.5	3	2.5	8	8	15	M12 x 18 (4x)	120	150 (15.0)	19910			33050	25	4.92	38.26
	150	CE	150															33850	20	5.64	45.24
	160	CE	160															34050	19	5.95	46.89
	175	CE	175															34250	17	6.44	48.10
	200	CE III	200															34840	15	7.15	51.38
	250	CE III	250															35640	12	8.61	56.99
	300	CE III	300															36040	10	10.15	67.93

CE The gas spring models for which the CE symbol is indicated have an internal gas volume > 1 litre (1 dm³). They fall into Category II or Category III (**CE III**) of the 2014/68/EU Pressure Equipment Directive (PED).

All the other gas spring models in this table are in accordance with Article 4.3 of the 2014/68/EU Pressure Equipment Directive (PED).

Les modèles à ressort à gaz pour lesquels le symbole CE est indiqué ont un volume de gaz interne > 1 litre (1 dm³). Ils relèvent de la catégorie II ou de la catégorie III (**CE III**) de la directive 2014/68/UE sur les équipements sous pression (PED). Tous les autres modèles de ressorts à gaz de ce tableau sont conformes à l'article 4.3 de la directive 2014/68/UE sur les équipements sous pression (PED).

"L-VERSION" (FOR LINKED SYSTEM) / « VERSION L » (POUR SYSTÈME LIÉ)

When the gas springs are to be used in a linked system, make sure to order the "L-version" by adding "-L" after the gas spring code. The "L-version" gas springs are supplied already discharged and without valve, ready for the connection to linked system.

Example: **"PGS4200-50-L"**

Lorsque les ressorts à gaz doivent être utilisés dans un système lié, assurez-vous de commander la « version L » en ajoutant « -L » après le code du ressort à gaz. Les ressorts à gaz « version L » sont fournis déjà déchargés et sans vanne, prêts pour le raccordement au système lié.

Exemple: **"PGS4200-50-L"**

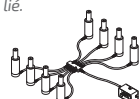

REPAIR KIT / KIT DE RÉPARATION

Gas spring code Code des ressorts à gaz	Repair kit code Code du kit de réparation
PGS2400-25 ~ PGS2400-125	KR/PGS2400-1
PGS2400-150 ~ PGS2400-300	KR/PGS2400-2
PGS4200-25 ~ PGS4200-125	KR/PGS4200-1
PGS4200-150 ~ PGS4200-300	KR/PGS4200-2
PGS6600-25 ~ PGS6600-125	KR/PGS6600-1
PGS6600-150 ~ PGS6600-300</	

FORCE RISE VS. USED STROKE LENGTH CHARTS

GRAP. AUGM. DE LA FORCE VS. COURSE UTILISÉE

The force curves in the charts below are obtained from reference values measured in static conditions. The actual forces generated under use conditions may vary, since they depend on the specific parameters of the application, such as the working speed (cycles per minute).

Les courbes de force dans les tableaux ci-dessous sont obtenues à partir de valeurs de référence mesurées dans des conditions statiques. Les forces réelles générées dans les conditions d'utilisation peuvent varier, car elles dépendent des paramètres spécifiques de l'application, tels que la vitesse de travail (cycles par minute).

PGS2400

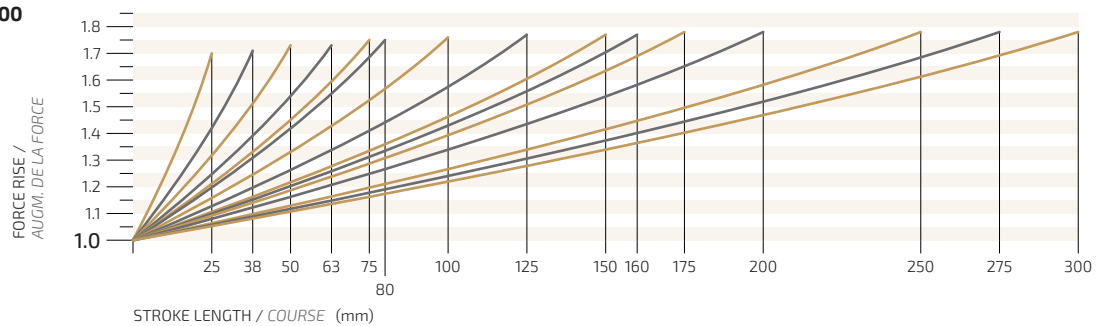

PGS4200

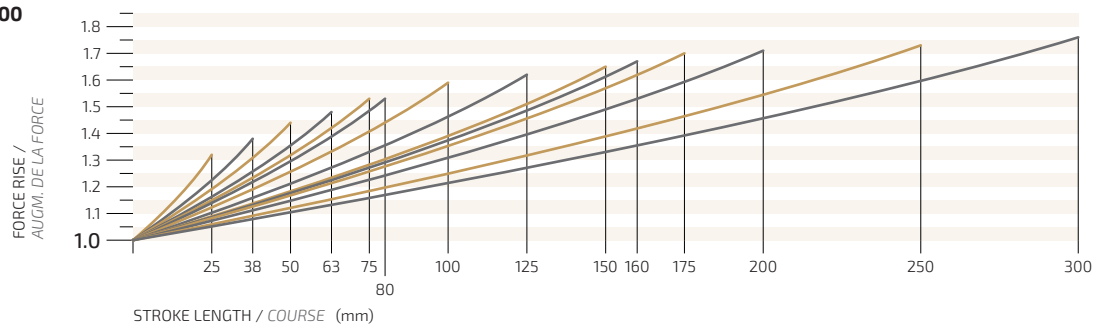

PGS6600

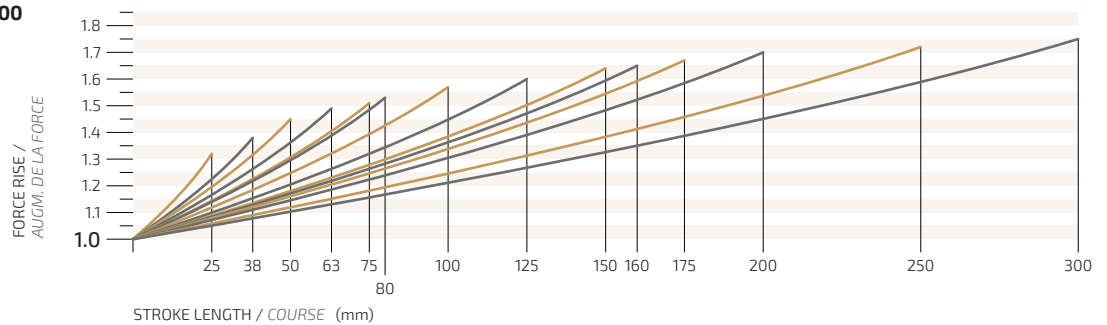

PGS9500

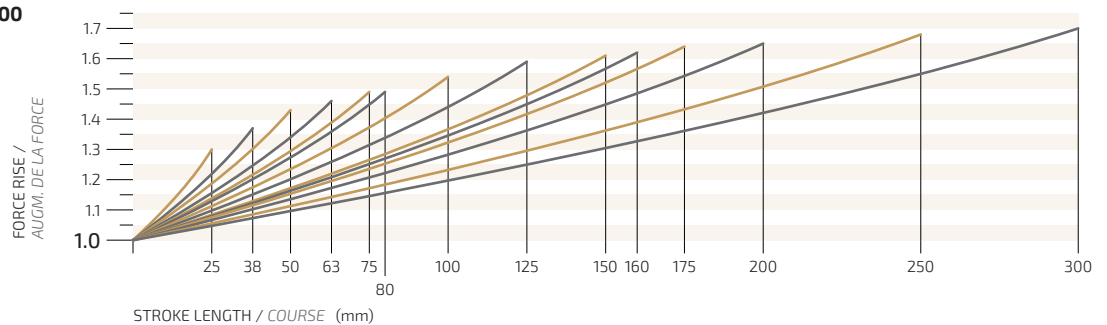

FORCE RISE VS. USED STROKE LENGTH CHARTS

The force curves in the charts below are obtained from reference values measured in static conditions. The actual forces generated under use conditions may vary, since they depend on the specific parameters of the application, such as the working speed (cycles per minute).

GRAP. AUGM. DE LA FORCE VS. COURSE UTILISÉE

Les courbes de force dans les tableaux ci-dessous sont obtenues à partir de valeurs de référence mesurées dans des conditions statiques. Les forces réelles générées dans les conditions d'utilisation peuvent varier, car elles dépendent des paramètres spécifiques de l'application, tels que la vitesse de travail (cycles par minute).

PGS20000

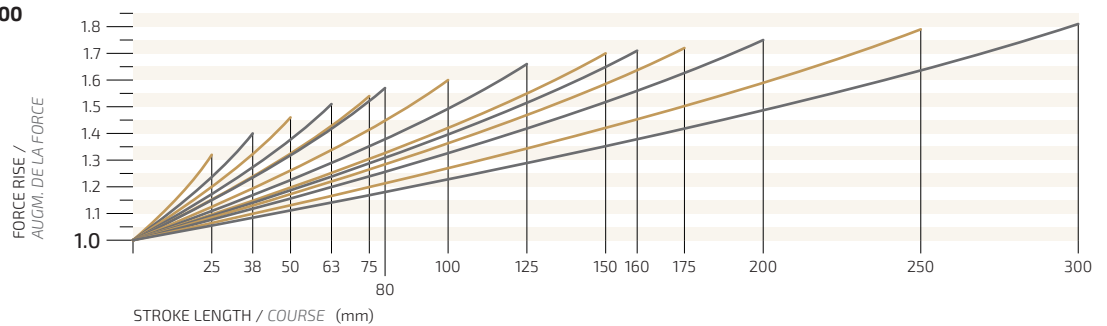

VV series nitrogen gas springs feature different dimensions and forces. VV series nitrogen gas springs are self-lubricated.

Les ressorts à gaz de la série VV présentent des dimensions et des forces différentes. Les ressorts à gaz de la série VV sont autolubrifiés.



Piston rod
surface roughness Ra ~ 0.02 µm
surface µ-hardness ~ 800 HV

Tige de piston
rugosité de surface Ra ~ 0.02 µm
dureté µ surface ~ 800 HV

Wiper ring
Racleur de tige

Rod guide
Guide-tige

Rod seal
Joint de tige

Single-piece body construction
Construction du corps monobloc

O-ring seal
Joint torique

Non-return valve
Clapet anti-retour

Side port (charging port)
VV2385 models = M6
VV750 and VV2945 models = G1/8
(other models: charging port at the bottom)
(charge with nitrogen N₂ only)

Port latéral (port de charge)
Modèles VV2385 = M6
Modèles VV750 et VV2945 = G1/8
(autres modèles : port de charge en bas)
(charge avec de l'azote N₂ uniquement)

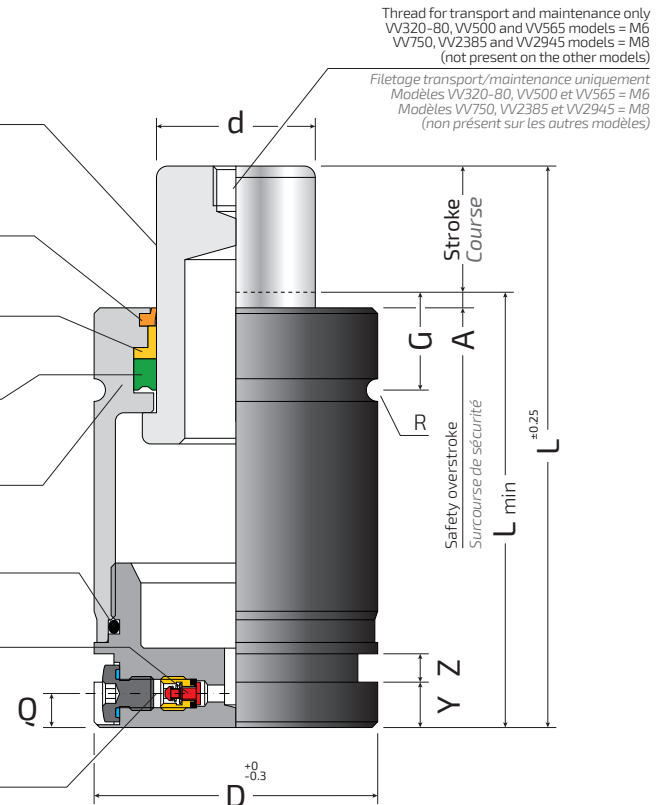

Technical notes / Notes techniques
Important use instructions
in the dedicated catalogue section.
Instructions d'utilisation importantes
dans la section dédiée au catalogue.

Fixing possibilities / Possibilités de fixation

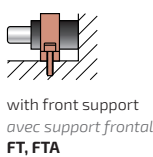
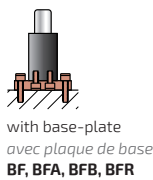
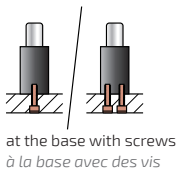

GAS SPRING BASE / BASE DU RESSORT À GAZ

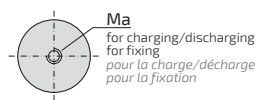

VV170, VV320-63/63H

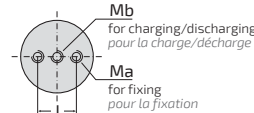

**VV320-80, VV500-63,
VV565-63**

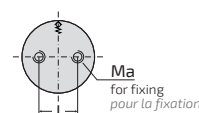

VV750

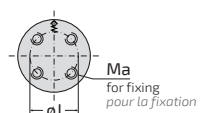

VV2385, VV2495

LINKING TO OPEN SYSTEM / LIAISON AU SYSTÈME OUVERT

Hoses Tuyaux	VV2385 (M6 side port / Port latéral M6)		VV750, VV2945 (G1/8 side port / Port latéral G1/8)		
	ATM	ATNM	ATM	ATN	AT
Gas spring-hose fittings Raccords ressort de gaz - tuyau	ARM	ARNM	ARM	ARN	AR

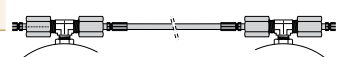

ATTENTION! Follow the instructions in the "LINKED SYSTEM" section before connecting the gas springs.
ATTENTION! Suivez les instructions de la section « SYSTÈME LIÉ » avant de connecter les ressorts à gaz.

SAFETY PROTECTIONS / PROTECTIONS DE SÉCURITÉ



**UNCONTROLLED
RETURN SPEED /
VITESSE DE RETOUR
INCONTRÔLÉE**



**OVERSTROKE /
SURCOURSE**



**OVERPRESSURE /
SURPRESSION**

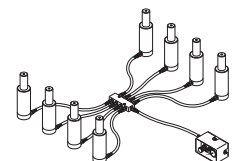

Model Modèle	MAX Stroke 100% usable MAX course 100% utilisable		Lmin mm	L mm	D mm	d mm	G mm	A mm	R mm	Y mm	Z mm	Q mm	Ma	J mm	Mb	bar (MPa)				Cycles per minute MAX Cycles par minute MAX	Gas volume Gaz volume dm ³	Weight Poids kg
	mm	mm																				
VV170-38	38	97	135																275	80	0.011	0.14
50	50	110	160	19	11	17	1	1	-	-	-		M6 x 10	-	-	180 (18.0)	170		285	60	0.014	0.17
63	63	127	190																285	50	0.017	0.18
VV320-63	63	127	190	25	15	17	1	1	-	-	-		M6 x 9	-	-	180 (18.0)	320		540	50	0.032	0.31
63H	63	145	208																500	50	0.038	0.33
VV320-80	80	125	205	32	15	-	2	-	-	-	-		M6 x 8 (2x)	18	M6	180 (18.0)	320		520	40	0.044	0.44
VV500-63	63	132	195	32	20	-	2	-	-	-	-		M5 x 8 (2x)	15	M6	160 (16.0)	500		830	50	0.058	0.48
VV565-63	63	142	205	32	20	-	2	-	-	-	-		M5 x 8 (2x)	15	M6	180 (18.0)	565		900	50	0.064	0.50
VV750-63	63	113	176	50	25	-	2	-	-	-	10.5		M8 x 13 (2x)	20	-	150 (15.0)	740		1280	50	0.085	1.40
80	80	130	210																1270	40	0.109	2.00
VV2385-80	80	128	208	75	45	21	3	2.5	-	-	6		M8 x 9 (4x)	40	-	150 (15.0)	2385		4250	40	0.33	2.48
100	100	148	248																4300	30	0.41	2.79
VV2945-63	62.5	182.5	245	95	50	-	3	-	-	-	10.5		M8 x 13 (4x)	60	-	150 (15.0)	2945		3950	50	0.70	5.16
80	80	138	218																4850	40	0.47	5.21
100	100	158	258																4850	30	0.60	5.09
125	125	183	308																4800	25	0.75	7.24

All the gas spring models in this table are in accordance with Article 4.3 of the 2014/68/EU Pressure Equipment Directive (PED)

Tous les modèles de ressorts à gaz de ce tableau sont conformes à l'article 4.3 de la directive 2014/68/UE sur les équipements sous pression (PED)

"L-VERSION" (FOR LINKED SYSTEM) / « VERSION L » (POUR SYSTÈME LIÉ)

When the gas springs are to be used in a linked system, make sure to order the "L-version" by adding "-L" after the gas spring code. The "L-version" gas springs are supplied already discharged and without valve, ready for the connection to linked system.

Example: "VV750-80-L"

Lorsque les ressorts à gaz doivent être utilisés dans un système lié, assurez-vous de commander la « version L » en ajoutant « -L » après le code du ressort à gaz. Les ressorts à gaz « version L » sont fournis déjà déchargés et sans vanne, prêts pour le raccordement au système lié.

Exemple: "VV750-80-L"

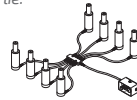

REPAIR KIT / KIT DE RÉPARATION

Gas spring code Code des ressorts à gaz	Repair kit code Code du kit de réparation
VV170-...	KR/VV170
VV320-63, VV320-63H	KR/VV320-63-63H
VV320-80	KR/VV320-80
VV500-63	KR/VV500
VV565-63	KR/VV565
VV750-...	KR/VV750
VV2385-...	KR/VV2385
VV2945-...	KR/VV2945

Download repair instructions from www.bordignon.com /

Téléchargez les instructions de réparation de www.bordignon.com

FORCE RISE VS. USED STROKE LENGTH CHARTS
GRAP. AUGM. DE LA FORCE VS. COURSE UTILISÉE

The force curves in the charts below are obtained from reference values measured in static conditions. The actual forces generated under use conditions may vary, since they depend on the specific parameters of the application, such as the working speed (cycles per minute).

Les courbes de force dans les tableaux ci-dessous sont obtenues à partir de valeurs de référence mesurées dans des conditions statiques. Les forces réelles générées dans les conditions d'utilisation peuvent varier, car elles dépendent des paramètres spécifiques de l'application, tels que la vitesse de travail (cycles par minute).

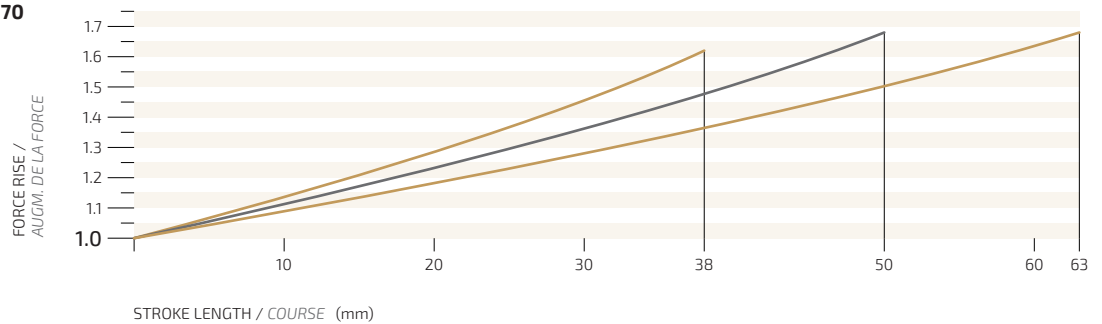
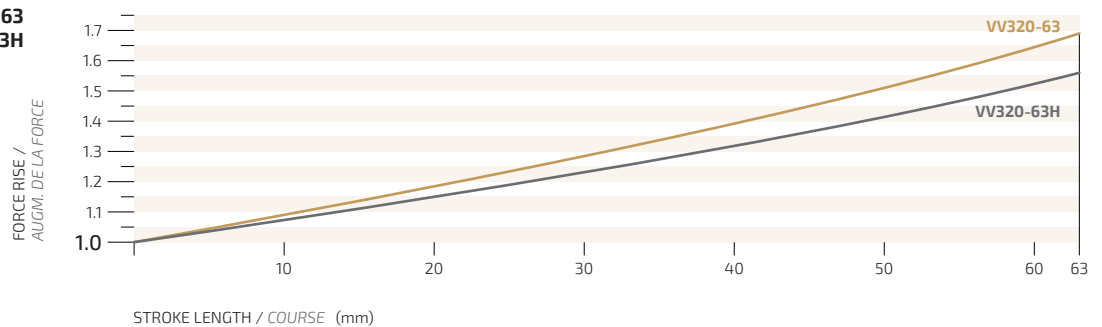
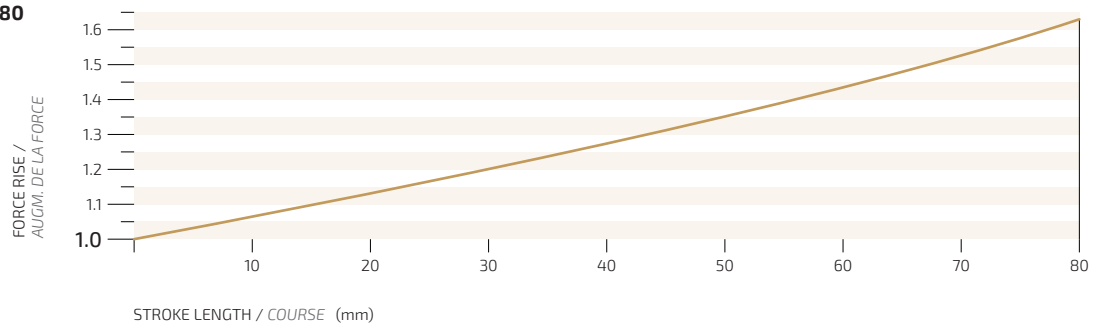
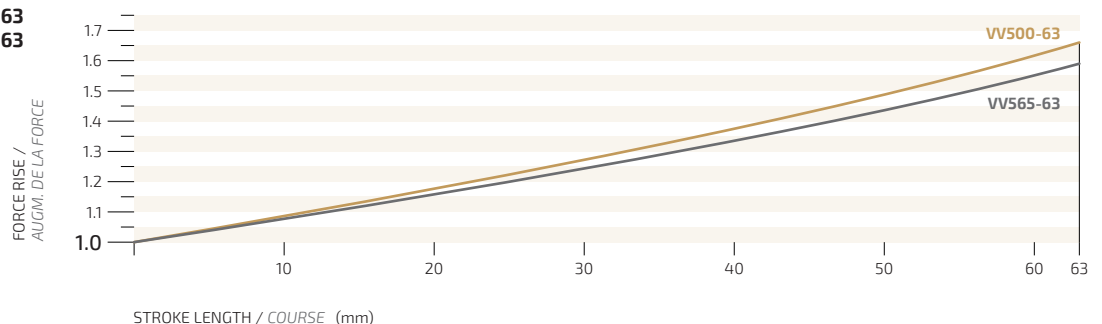
VV170

**VV320-63
VV320-63H**

VV320-80

**VV500-63
VV565-63**

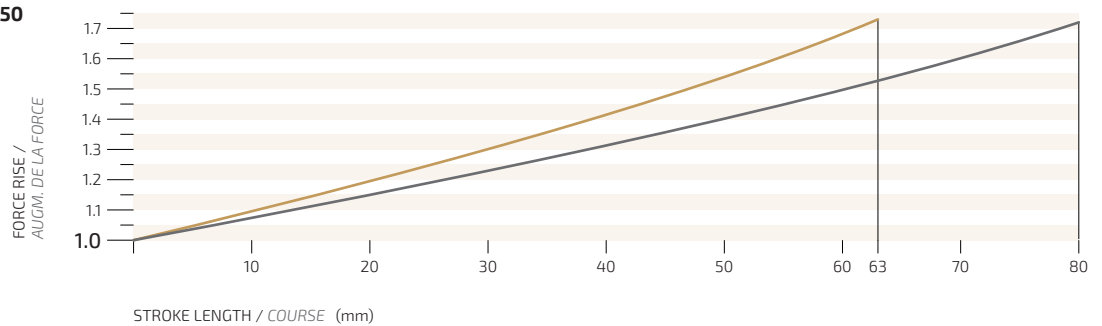
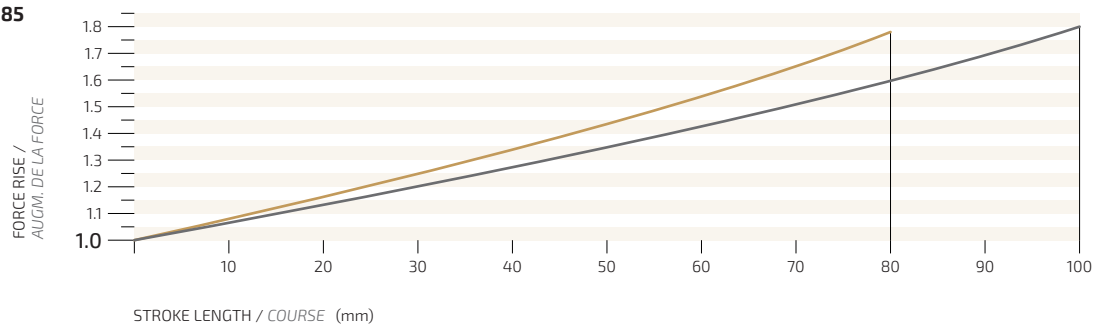
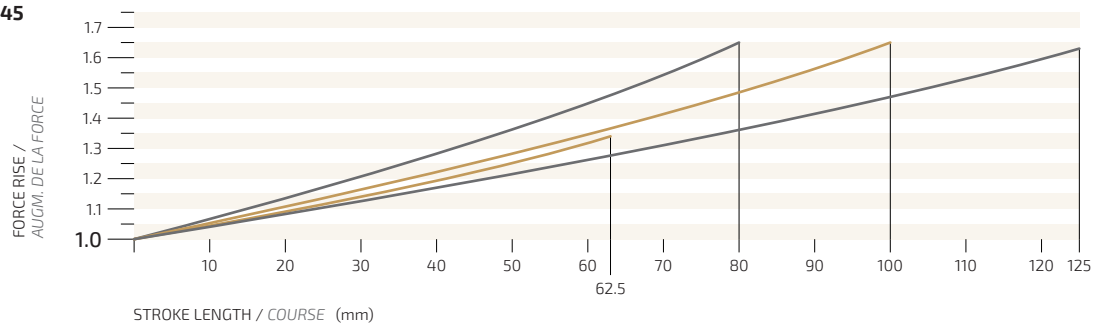
FORCE RISE VS. USED STROKE LENGTH CHARTS
GRAP. AUGM. DE LA FORCE VS. COURSE UTILISÉE

The force curves in the charts below are obtained from reference values measured in static conditions. The actual forces generated under use conditions may vary, since they depend on the specific parameters of the application, such as the working speed (cycles per minute).

Les courbes de force dans les tableaux ci-dessous sont obtenues à partir de valeurs de référence mesurées dans des conditions statiques. Les forces réelles générées dans les conditions d'utilisation peuvent varier, car elles dépendent des paramètres spécifiques de l'application, tels que la vitesse de travail (cycles par minute).

VV750

VV2385

VV2945

BF



This series includes the models compliant with automotive standards /
Série de modèles conformes aux normes automobiles

General Motors	90.25.04
PSA	E24.54.815.G
Renault	EM24.54.700

Fixing base plate / Plaque de base de fixation

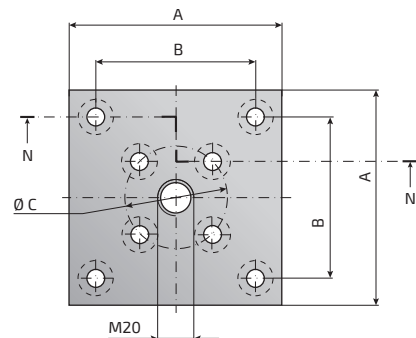
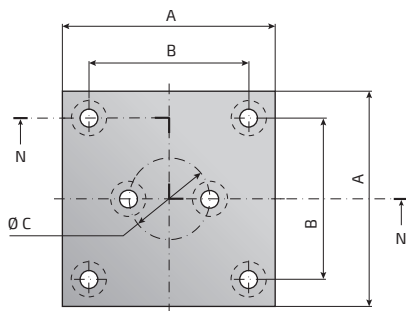
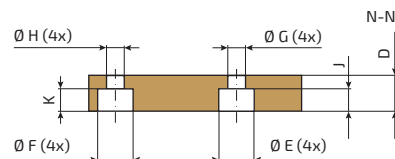
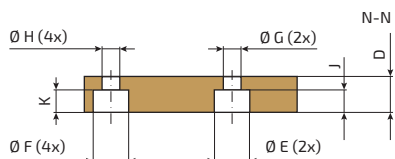
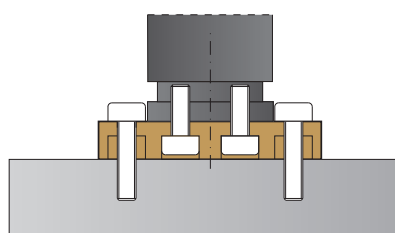
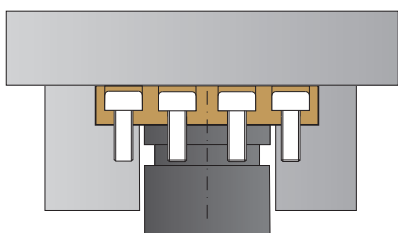

FIG. 1

FIG. 2

Model Modèle	Reference to Standards Référence aux normes	For models... Pour les modèles...	A mm	B mm	Ø C mm	D mm	Ø E mm	Ø F mm	Ø G mm	Ø H mm	J mm	K mm	FIG.
BF 45	ISO 11901-2, VDI 3003	AGS750, IGS500, LGS500, PGS750	70	50	20	20	15	15	9	9	14	12	1
50	ISO 11901-2, VDI 3003	AGS1000, AGS1200, AGS1500, IGS750, PGS1000, PGS1500, VV750	75	56.5	20	20	15	15	9	9	14	12	1
63	ISO 11901-2	AGS1500, PGS1500	100	73.5	20	20	15	18	9	11	14	12	1
75	ISO 11901-2, VDI 3003	AGS2400, TGS5000, IGS1500, PGS2400, VV2385	100	73.5	40	20	15	18	9	11	14	12	2
95	ISO 11901-2, VDI 3003	AGS4200, IGS3000, PGS4200, VV2945	120	92	60	20	15	20	9	13.5	14	13	2
120	ISO 11901-2, VDI 3003	AGS6600, IGS5000, PGS6600	140	109.5	80	20	18	20	11	13.5	15	13	2
150	ISO 11901-2, VDI 3003	AGS9500, IGS7500, PGS9500	190	138	100	25	18	26	11	17.5	15	17	2
195	ISO 11901-2, VDI 3003	AGS20000, IGS10000, PGS20000	210	170	120	25	20	26	13.5	17.5	13	17	2

Fixing possibilities / Possibilités de fixation



BFA

This series includes the models compliant with automotive standards /
Série de modèles conformes aux normes automobiles

Renault EM24.54.700

Fixing base plate / Plaque de base de fixation

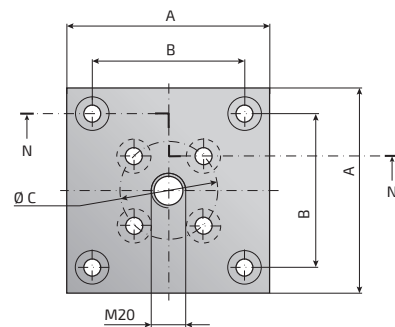
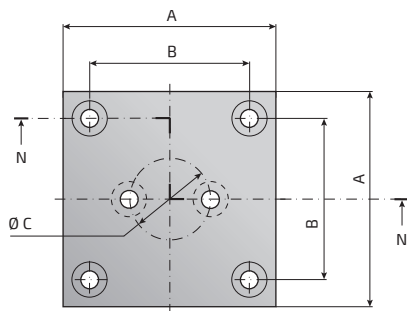
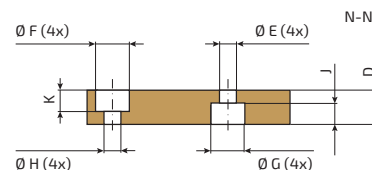
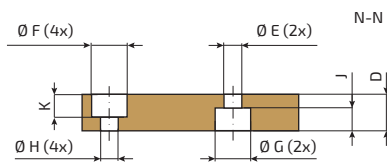
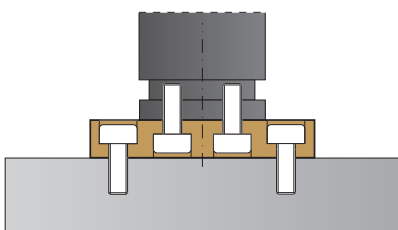

FIG. 1

FIG. 2

Model Modèle	Reference to Standards Référence aux normes	For models... Pour les modèles...	A mm	B mm	Ø C mm	D mm	Ø E mm	Ø F mm	Ø G mm	Ø H mm	J mm	K mm	FIG.
BFA 45	-	AGS750, IGS500, LGS500, PGS750	70	50	20	20	9	18	15	11	14	12	1
50	-	AGS1000, AGS1200, AGS1500, IGS750, PGS1000, PGS1500, VV750	75	56.5	20	20	9	18	15	11	14	12	1
75	-	AGS2400, TGS5000, IGS1500, PGS2400, VV2385	100	73.5	40	20	9	18	15	11	14	12	2
95	-	AGS4200, IGS3000, PGS4200, VV2945	120	92	60	20	9	20	15	13.5	14	13	2
120	-	AGS6600, IGS5000, PGS6600	140	109.5	80	20	11	20	18	13.5	15	13	2
150	-	AGS9500, IGS7500, PGS9500	190	138	100	25	11	26	18	17.5	15	17	2
195	-	AGS20000, IGS10000, PGS20000	210	170	120	25	13.5	26	20	17.5	15	17	2

Fixing possibilities / Possibilités de fixation



BFB

Fixing base plate / Plaque de base de fixation

This series includes the models compliant with automotive standards /
Série de modèles conformes aux normes automobiles

BMW	BZ 4009
MB	BB 0132 110 008 801
Renault	EM24.54.700

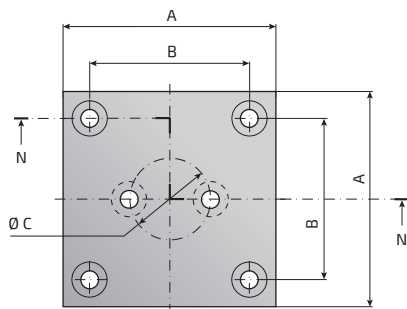
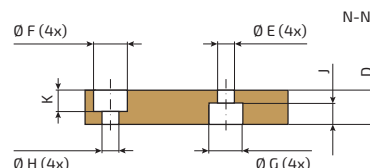
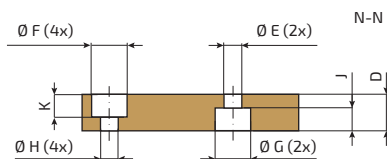

FIG. 1

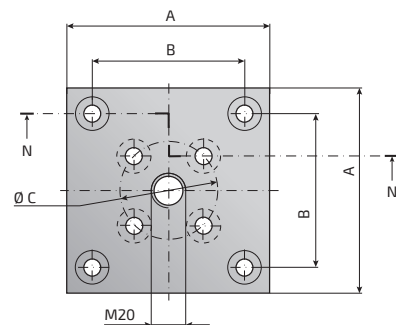
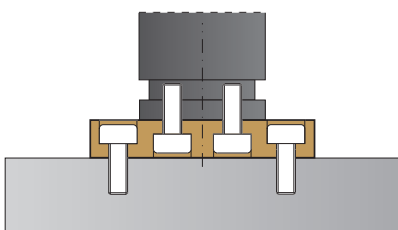

FIG. 2

Model Modèle	Reference to Standards Référence aux normes	For models... Pour les modèles...	A mm	B mm	Ø C mm	D mm	Ø E mm	Ø F mm	Ø G mm	Ø H mm	J mm	K mm	FIG.
BFB 45	-	AGS750, IGS500, LGS500, PGS750	70	50	20	20	9	15	15	9	12	12	1
50	-	AGS1000, AGS1200, AGS1500, IGS750, PGS1000, PGS1500, VV750	75	56.5	20	20	9	15	15	9	12	12	1
63	-	AGS1500, PGS1500	100	73.5	20	20	9	18	15	11	12	12	1
75	-	AGS2400, TGS5000, IGS1500, PGS2400, VV2385	100	73.5	40	20	9	18	15	11	12	14	2
95	-	AGS4200, IGS3000, PGS4200, VV2945	120	92	60	20	9	20	15	13.5	14	13	2
120	-	AGS6600, IGS5000, PGS6600	140	109.5	80	20	11	20	18	13.5	15	13	2
150	-	AGS9500, IGS7500, PGS9500	190	138	100	20	11	20	18	13.5	15	13	2
195	-	AGS20000, IGS10000, PGS20000	210	170	120	25	13.5	26	20	17.5	15	17	2

Fixing possibilities / Possibilités de fixation



BFR

Fixing base plate / Plaque de base de fixation

This series includes the models compliant with automotive standards /
Série de modèles conformes aux normes automobiles

Renault	EM24.54.700
Nissan	K32P0, K32D2

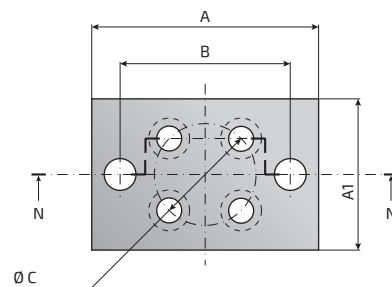
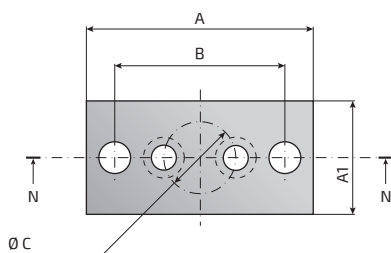
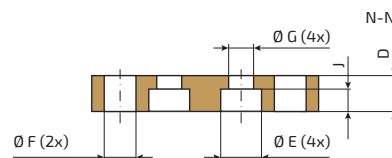
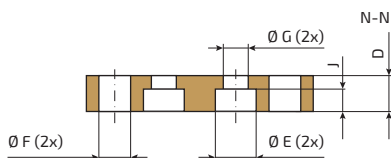
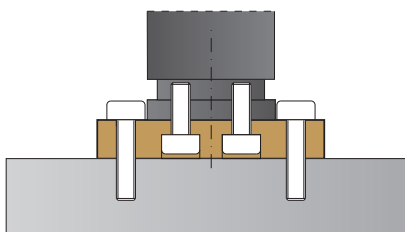

FIG. 1

FIG. 2

Model Modèle	Reference to Standards Référence aux normes	For models... Pour les modèles...	A mm	A1 mm	B mm	Ø C mm	D mm	Ø E mm	Ø F mm	Ø G mm	J mm	FIG.
BFR 45 A	-	AGS750, IGS500, LGS500, PGS750	90	45	70	20	16	14	9	9	10	1
50 B	-	AGS1000, AGS1200, IGS750, PGS1000, VV750	100	50	75	20	19	14	14	9	13	1
75 B	-	AGS1500, AGS2400, TGS5000, IGS1500, PGS1500, PGS2400, VV2385	130	80	105	40	19	14	14	9	13	2
95 B	-	AGS4200, IGS3000, PGS4200, VV2945	150	100	125	60	19	14	14	9	13	2

Fixing possibilities / Possibilités de fixation



SF



This series includes the models compliant with automotive standards /
Série de modèles conformes aux normes automobiles

BMW	BZ 4009	MB	B8 0138 100 000 001
FCA	075.90.90	Renault	EMZ4.54.700
Ford	W-DX35-62M	VW	39D 848
General Motors	90.25.01		

Fixing half-flanges / Fixation des demi-brides

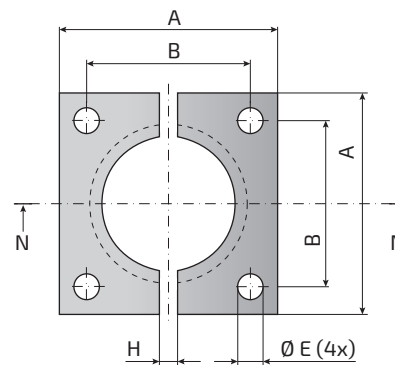
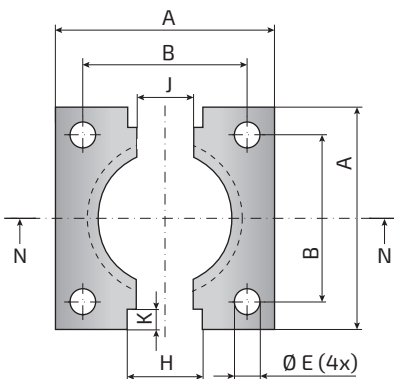
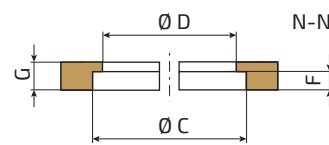
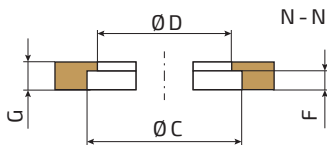
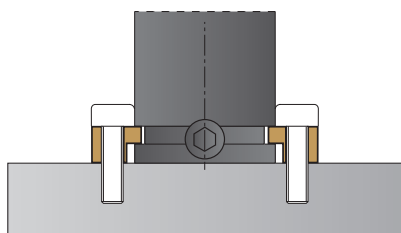

FIG. 1

FIG. 2

Model Modèle	Reference to Standards Référence aux normes	For models... Pour les modèles...	A mm	B mm	Ø C mm	Ø D mm	Ø E mm	F mm	G mm	H mm	J mm	K mm	FIG.
SF 32	-	AGS350, TGS700, IGS150, PGS300	50	35	32.5	28.5	6.6	4	7	21	17	6.5	1
38	-	AGS500, TGS1000, IGS250, PGS500	55	40	38.5	34.5	6.6	4	7	21	17	6.5	1
45	ISO 11901-2, VDI 3003	AGS750, IGS500, LGS500, PGS750	70	50	45.5	41.5	9	4	7	20	-	-	2
50	ISO 11901-2, VDI 3003	AGS1000, AGS1200, TGS2000, IGS750, PGS1000	75	56.5	50.5	44.5	9	8	12	24	-	-	2
63	-	AGS1500, TGS3000, PGS1500	85	63.5	63.5	57.5	11	8	12	24	-	-	2
63 A	ISO 11901-2	AGS1500, TGS3000, PGS1500	100	73.5	64	57	11	8	12	24	-	-	2
75	ISO 11901-2, VDI 3003	AGS2400, TGS5000, IGS1500, PGS2400	100	73.5	75.5	68.5	11	8	12	24	-	-	2
95	ISO 11901-2, VDI 3003	AGS4200, TGS8000, IGS3000, PGS4200	120	92	95.5	88.5	13.5	8	12	24	-	-	2
120	ISO 11901-2, VDI 3003	AGS6600, TGS12000, IGS5000, PGS6600	140	109.5	120.5	113.5	13.5	8	12	24	-	-	2
150	ISO 11901-2, VDI 3003	AGS9500, TGS20000, IGS7500, PGS9500	190	138	150.5	143.5	17.5	8	12	24	-	-	2
195	ISO 11901-2, VDI 3003	AGS20000, IGS10000, PGS20000	210	170	195.5	188	17.5	8	13	24	-	-	2

Fixing possibilities / Possibilités de fixation



SFA

Fixing half-flanges / Fixation des demi-bridés

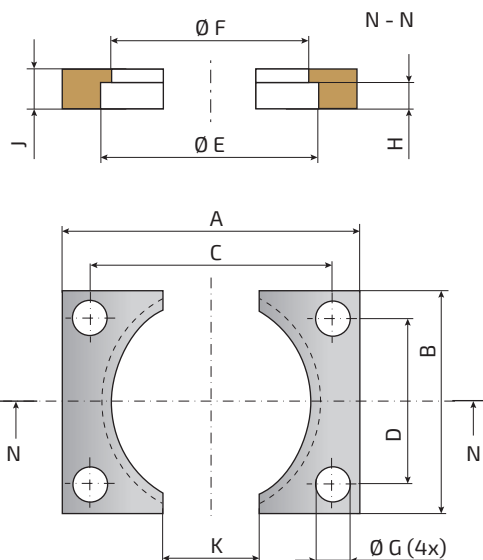

Model Modèle	Reference to Standards Référence aux normes	For models... Pour les modèles...	A mm	B mm	C mm	D mm	Ø E mm	Ø F mm	Ø G mm	H mm	J mm	K mm
SFA 32	-	AGS350, TGS700, IGS150, PGS300	50	27	40	18	32.5	28.5	6.6	4	7	20
38	-	AGS500, TGS1000, IGS250, PGS500	55	33	44	20	38.5	34.5	6.6	4	7	20
45	-	AGS750, IGS500, LGS500, PGS750	70	40	57	27	45.5	41.5	9	4	7	25
50	-	AGS1000, AGS1200, TGS2000, IGS750, PGS1000	75	45	62	32	50.5	44.5	9	8	12	25
63	-	AGS1500, TGS3000, PGS1500	85	58	69	42	63.5	57.5	11	8	12	30
75	-	AGS2400, TGS5000, IGS1500, PGS2400	100	70	84	54	75.5	68.5	11	8	12	30
95	-	AGS4200, TGS8000, IGS3000, PGS4200	120	90	100	70	95.5	88.5	13.5	8	12	40
120	-	AGS6600, TGS12000, IGS5000, PGS6600	140	115	120	95	120.5	113.5	13.5	8	12	50
150	-	AGS9500, TGS20000, IGS7500, PGS9500	190	145	165	120	150.5	143.5	17.5	8	12	60
195	-	AGS20000, IGS10000, PGS20000	210	190	185	165	195.5	188	17.5	8	13	80

Fixing possibilities / Possibilités de fixation

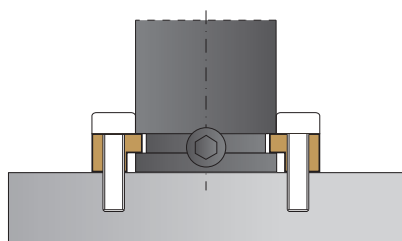

Fixing foot brackets / Fixation des supports de pied

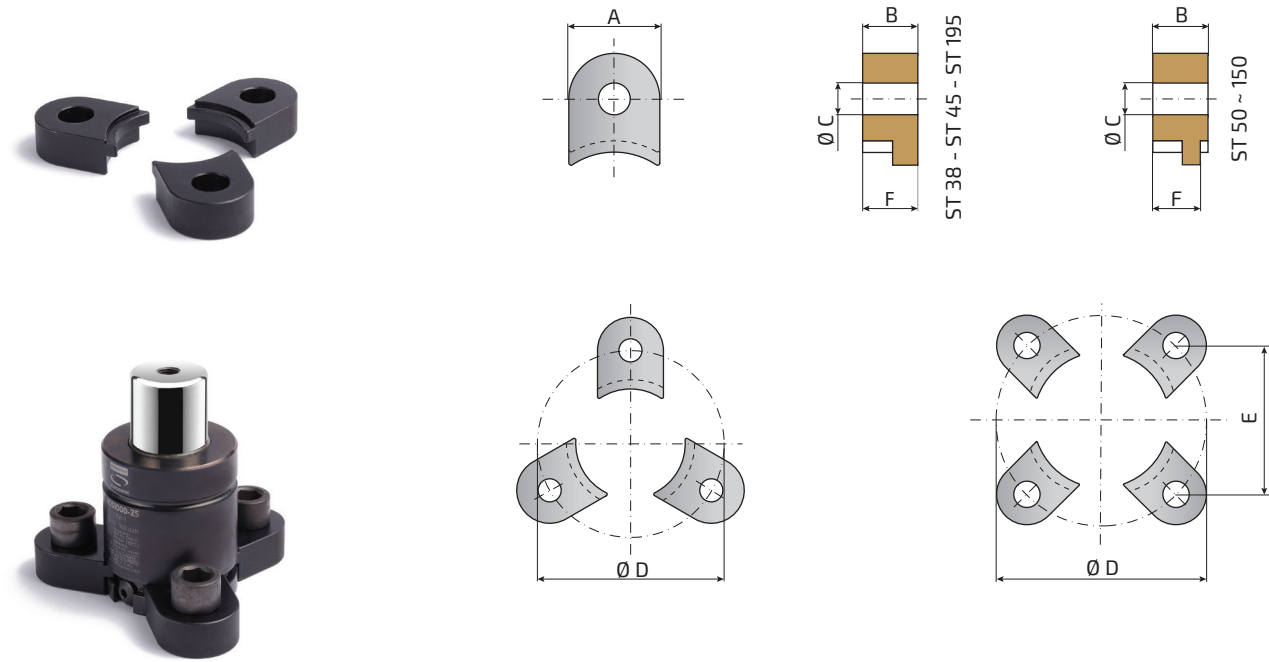

FIG. 1

FIG. 2

Model Modèle	Reference to Standards Référence aux normes	For models... Pour les modèles...	A mm	B mm	C mm	Ø D mm	E mm	F mm	FIG.
ST 38	-	AGS500, TGS1000, IGS250, PGS500	20	7	7	56.6	-	7	1
45	-	AGS750, IGS500, LGS500, PGS750	25	7	9	70.7	-	7	1
50	-	AGS1000, AGS1200, TGS2000, IGS750, PGS1000	30	14.2	13	80	-	13	1
63	-	AGS1500, TGS3000, PGS1500	30	14.2	13	92	65	13	2
75	-	AGS2400, TGS5000, IGS1500, PGS2400	30	14.2	13	104	73.5	13	2
95	-	AGS4200, TGS8000, IGS3000, PGS4200	40	14.2	17	130	92	13	2
120	-	AGS6600, TGS12000, IGS5000, PGS6600	50	14.2	17	155	109.5	13	2
150	-	AGS9500, TGS20000, IGS7500, PGS9500	50	14.2	21	195	138	13	2
195	-	AGS20000, IGS10000, PGS20000	58	16	21	240	169	16	2

Fixing possibilities / Possibilités de fixation



Fixing foot brackets / Fixation des supports de pied

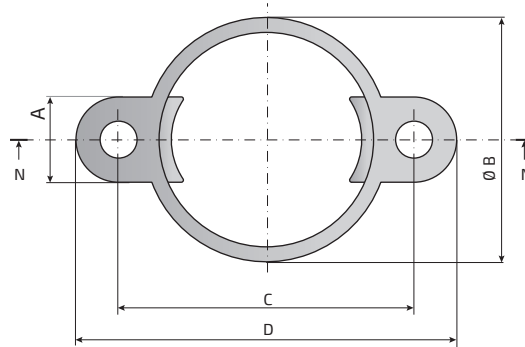
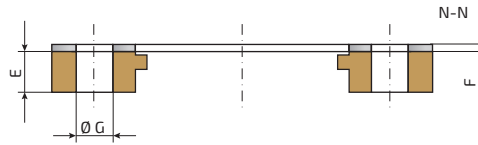

Model Modèle	Reference to Standards Référence aux normes	For models... Pour les modèles...	A mm	Ø B mm	C mm	D mm	E mm	F mm	Ø G mm
STA 38	-	AGS500, TGS1000, IGS250, PGS500	20	48	56.6	76.6	7	2.5	7
45	-	AGS750, IGS500, LGS500, PGS750	25	56	70.7	95.7	7	2.5	9
50	-	AGS1000, AGS1200, TGS2000, IGS750, PGS1000	30	61	80	110	14.2	2.5	13
63	-	AGS1500, TGS3000, PGS1500	30	73	92	122	14.2	2.5	13
75	-	AGS2400, TGS5000, IGS1500, PGS2400	30	86	104	134	14.2	2.5	13
95	-	AGS4200, TGS8000, IGS3000, PGS4200	40	106	130	170	14.2	2.5	17
120	-	AGS6600, TGS12000, IGS5000, PGS6600	50	131	155	205	14.2	2.5	17
150	-	AGS9500, TGS20000, IGS7500, PGS9500	50	170	195	245	14.2	2.5	21

Fixing possibilities / Possibilités de fixation

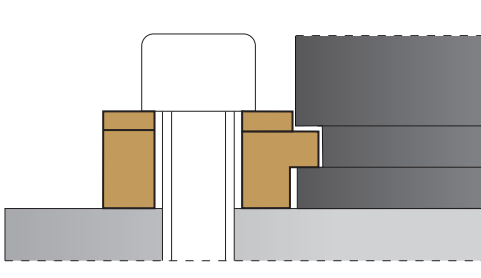

FV

Collar flange (for base-fixing) / Bride de collerette (pour la fixation de la base)

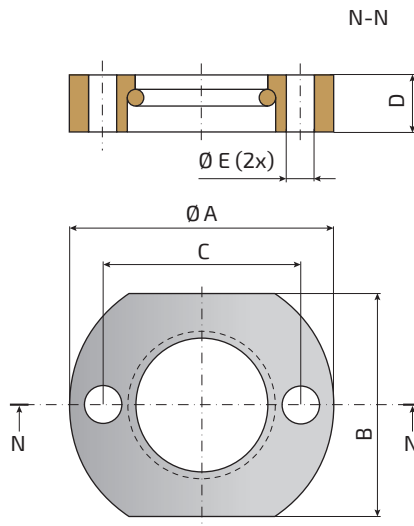

Model Modèle	Reference to Standards Référence aux normes	For models... Pour les modèles...	Ø A mm	B mm	C mm	D mm	Ø E mm
FV 19	-	VG590	45	25	32	9.2	7

Fixing possibilities / Possibilités de fixation

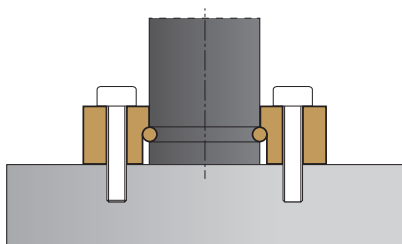

FL 12~25



This series includes the models compliant with automotive standards /
Série de modèles conformes aux normes automobiles

BMW	B2 4009	MB	B8 0134 400 008 801
FCA	075.90.75	PSA	E24.54.815.G
Ford	W-DX35-80M	VW	39D 848

Collar flange / Bride de collier

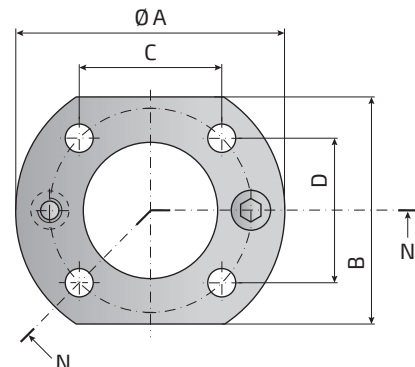
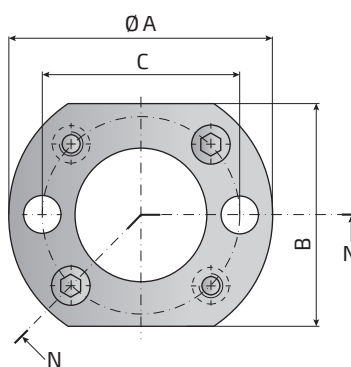
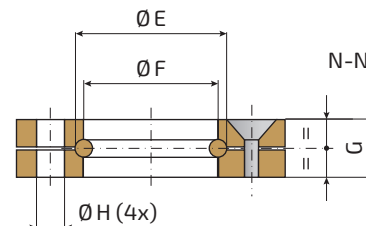
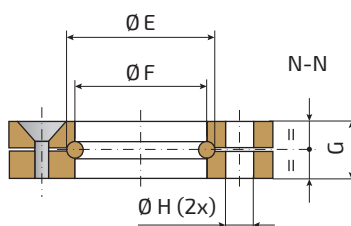
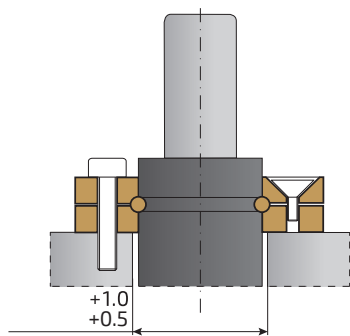

FIG. 1

FIG. 2

Model Modèle	Reference to Standards Référence aux normes	For models... Pour les modèles...	Ø A mm	B mm	C mm	D mm	Ø E mm	Ø F mm	G mm	Ø H mm	FIG.
FL 12	-	VGS50	34	21	24	-	13.6	12.5	9	6.6	1
15	-	VGS70	37	24	27	-	16.6	15.5	9	6.6	1
19 A	VDI 3003	VGS90, AGS170, VV170	44	25	32	-	21	19.5	9	6.6	1
19 B	ISO 11901-2	VGS90, AGS170, VV170	44	25	30	12	21	19.5	9	6.6	2
25 A	VDI 3003	VGS200, AGS320, TGS400, VV320-63/63H	50	30	38	-	27	25.5	9	6.6	1
25 B	ISO 11901-2	VGS200, AGS320, TGS400, VV320-63/63H	50	30	34	18	27	25.5	9	6.6	2

Fixing possibilities / Possibilités de fixation



Body Ø

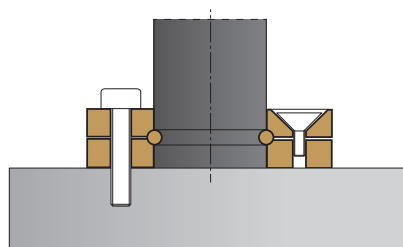

(For VGS200 and TGS400 models only)
(Pour les modèles VGS200 et TGS400 uniquement)

FL 32~195



This series includes the models compliant with automotive standards /
Série de modèles conformes aux normes automobiles

BMW	BZ 4009	MB	B8 0134 300 000 001
FCA	075.90.80	Renault	EM24.54.700
General Motors	90.25.03		

Collar flange / Bride de collier

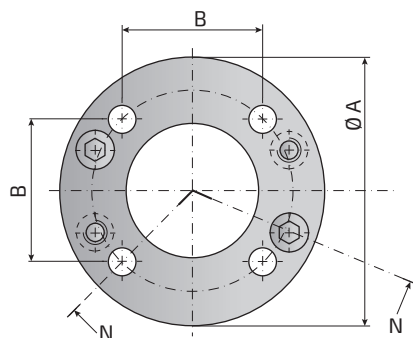
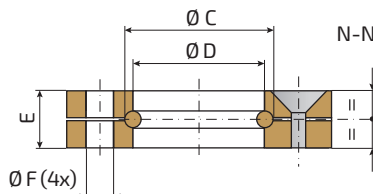

Model Modèle	Reference to Standards Référence aux normes	For models... Pour les modèles...	Ø A mm	B mm	Ø C mm	Ø D mm	E mm	Ø F mm
FL 32	ISO 11901-2, VDI 3003	AGS350, TGS700, IGS150, PGS300	60	35	34	32.5	9	6.6
38	ISO 11901-2, VDI 3003	AGS500, TGS1000, IGS250, PGS500	68	40	40	38.5	9	6.6
45	ISO 11901-2, VDI 3003	AGS750, IGS500, LGS500, PGS750	86	50	47	45.5	13	9
50	ISO 11901-2, VDI 3003	AGS1000, AGS1200, IGS750, PGS1000	95	56.5	54	50.5	13	9
63	ISO 11901-2	AGS1500, TGS3000, PGS1500	122	73.5	67	63.5	16	11
75	ISO 11901-2, VDI 3003	AGS2400, IGS1500, PGS2400, VV2385	122	73.5	80	75.5	16	11
95	ISO 11901-2, VDI 3003	AGS4200, IGS3000, PGS4200	150	92	100	95.5	18	13.5
120	ISO 11901-2, VDI 3003	AGS6600, TGS12000, IGS5000, PGS6600	175	109.5	125	120.5	21	13.5
150	ISO 11901-2, VDI 3003	AGS9500, TGS20000, IGS7500, PGS9500	220	138	155	150.5	27	17.5
195	ISO 11901-2, VDI 3003	AGS20000, IGS10000, PGS20000	290	170	200	195.5	27	17.5

Fixing possibilities / Possibilités de fixation

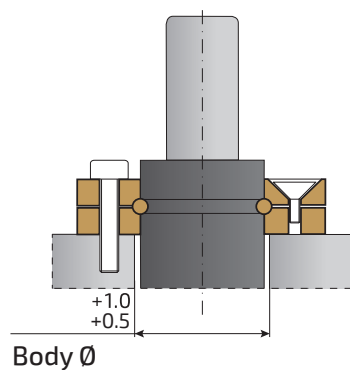

FLA

This series includes the models compliant with automotive standards /
Série de modèles conformes aux normes automobiles

Renault EM24.54.700

Collar flange / Bride de collier

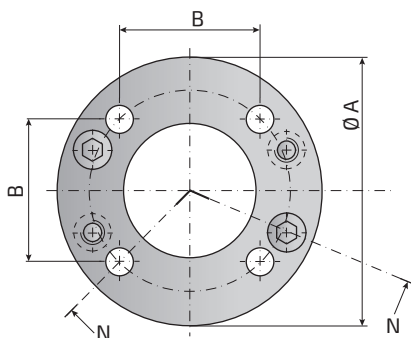
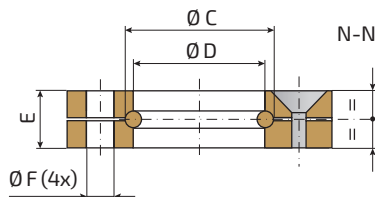

Model Modèle	Reference to Standards Référence aux normes	For models... Pour les modèles...	Ø A mm	B mm	Ø C mm	Ø D mm	E mm	Ø F mm
FLA 50	-	TGS2000	95	56.5	53	50.5	13	9
75	-	TGS5000	122	73.5	78	75.5	16	11
95	-	TGS8000	150	92	98	95.5	18	13.5

Fixing possibilities / Possibilités de fixation

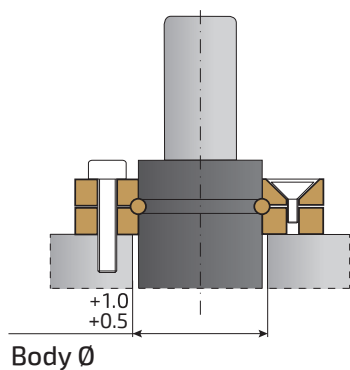

FLQ



This series includes the models compliant with automotive standards /
Série de modèles conformes aux normes automobiles

BMW	B2 4009	General Motors	90.25.02
FCA	075.90.85	VW	39D 848
Ford	W-DX35-62M		

Collar flange / Bride de collier

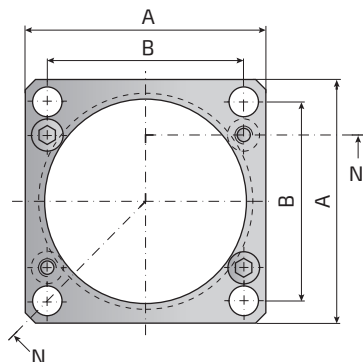
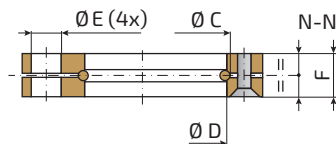

Model Modèle	Reference to Standards Référence aux normes	For models... Pour les modèles...	A mm	B mm	Ø C mm	Ø D mm	Ø E mm	F mm
FLQ 32	ISO 11901-2, VDI 3003	AGS350, TGS700, IGS150, PGS300	45	35	34	32.5	6.6	9
38	ISO 11901-2, VDI 3003	AGS500, TGS1000, IGS250, PGS500	52	40	40	38.5	6.6	9
45	ISO 11901-2, VDI 3003	AGS750, IGS500, LGS500, PGS750	64	50	47	45.5	9	13
50	ISO 11901-2, VDI 3003	AGS1000, AGS1200, IGS750, PGS1000	70	56.5	54	50.5	9	13
63 A	ISO 11901-2, VDI 3003	AGS1500, TGS3000, PGS1500	80	64	67	63.5	11	16
63 B	-	AGS1500, TGS3000, PGS1500	90	73.5	67	63.5	11	16
75	ISO 11901-2, VDI 3003	AGS2400, IGS1500, PGS2400, VV2385	90	73.5	80	75.5	11	16
95	ISO 11901-2, VDI 3003	AGS4200, IGS3000, PGS4200	110	92	100	95.5	13.5	18
120	ISO 11901-2, VDI 3003	AGS6600, TGS12000, IGS5000, PGS6600	130	109.5	125	120.5	13.5	21
150	ISO 11901-2, VDI 3003	AGS9500, TGS20000, IGS7500, PGS9500	162	138	155	150.5	17.5	27
195	ISO 11901-2, VDI 3003	AGS20000, IGS10000, PGS20000	210	170	200	195.5	17.5	27

Fixing possibilities / Possibilités de fixation

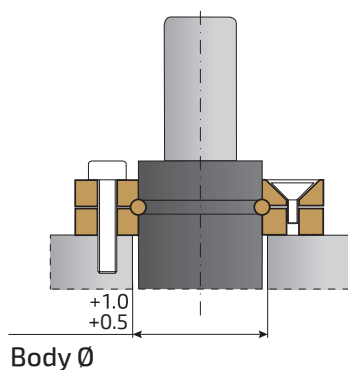

FLQA

Collar flange / Bride de collier

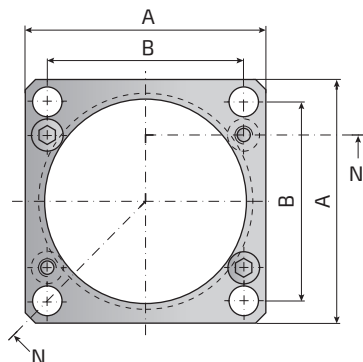
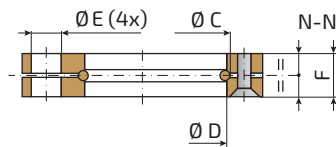

Model Modèle	Reference to Standards Référence aux normes	For models... Pour les modèles...	A mm	B mm	$\varnothing C$ mm	$\varnothing D$ mm	$\varnothing E$ mm	F mm
FLQA 50	-	TGS2000	70	56.5	53	50.5	9	13
75	-	TGS5000	90	73.5	78	75.5	11	16
95	-	TGS8000	110	92	98	95.5	13.5	18

Fixing possibilities / Possibilités de fixation

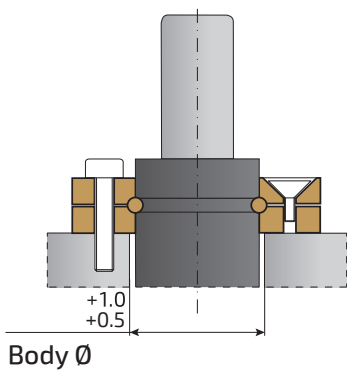



This series includes the models compliant with automotive standards /
Série de modèles conformes aux normes automobiles

BMW	B2 4009	PSA	E24.54.815.G
General Motors	90.25.455		

Front support / Support avant

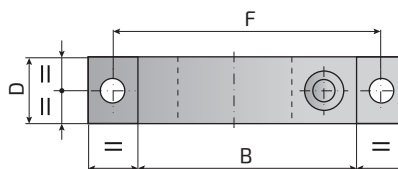
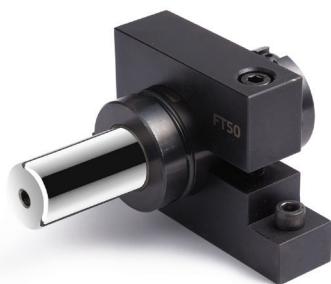
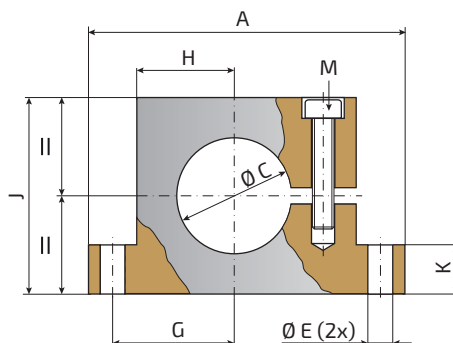
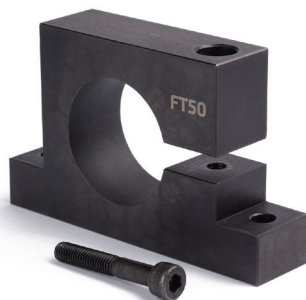

Model Modèle	Reference to Standards Référence aux normes	For models... Pour les modèles...	A mm	B mm	ØC mm	D mm	ØE mm	F mm	G mm	H mm	J mm	K mm	M
FT 32	VDI 3003	AGS350, TGS700, IGS150, PGS300, VV320-80, VV500, VV565	90	54	32	20	9	72	31	22	45	15	M8
38	VDI 3003	AGS500, TGS1000, IGS250, PGS500	95	59	38	20	9	77	34	25	55	15	M8
45	VDI 3003	AGS750, IGS500, LGS500, PGS750	100	64	45	20	9	82	37	28	60	15	M8
50	ISO 11901-2, VDI 3003	AGS1000, AGS1200, TGS2000, IGS750, PGS1000, VV750	130	90	50	30	9	110	50	40	80	20	M8
75	ISO 11901-2, VDI 3003	AGS2400, TGS5000, IGS1500, PGS2400, VV2385	160	115	75	30	11	137	63.5	52.5	105	20	M10
95	ISO 11901-2, VDI 3003	AGS4200, TGS8000, IGS3000, PGS4200, VV2945	195	145	95	30	13.5	170	80	67.5	125	20	M12
120	ISO 11901-2, VDI 3003	AGS6600, TGS12000, IGS5000, PGS6600	220	165	120	30	13.5	195	92.5	77.5	148	20	M12
150	ISO 11901-2, VDI 3003	AGS9500, TGS20000, IGS7500, PGS9500	260	200	150	30	13.5	230	110	95	200	20	M12

Fixing possibilities / Possibilités de fixation

MAX
0.5 x diameter of the gas spring body
0.5 x diamètre du corps du ressort à gaz

MIN
1/3 (one third) of dimension Lmin of the gas spring
1/3 (un tiers) de la dimension Lmin du ressort à gaz

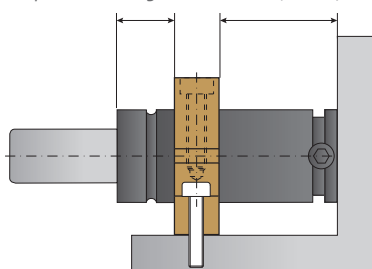

Dimension **MIN** must be respected to allow the over-pressure and over-stroke safety system to work properly (see dedicated catalogue section).

La dimension **MIN** doit être respectée pour permettre au système de sécurité en cas de surpression et de surcourse de fonctionner correctement (voir rubrique catalogue dédiée).

BMW	B2 4009	General Motors	90.25.07
FCA	075.90.95	MB	BB...
Ford	W-DX35-62M	VW	39D 848

Front support / Support avant

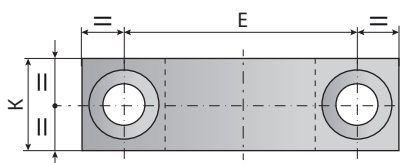
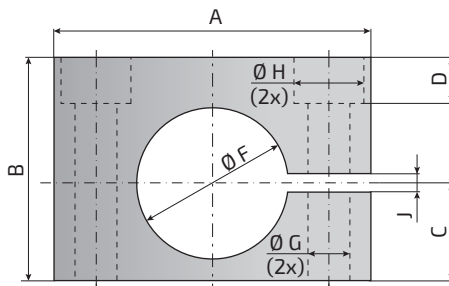
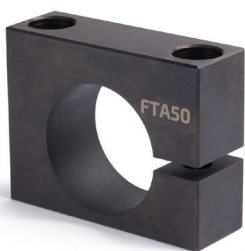

Model Modèle	Reference to Standards Référence aux normes	For models... Pour les modèles...	A mm	B mm	C mm	D mm	E mm	Ø F mm	Ø G mm	Ø H mm	J mm	K mm
FTA 32	ISO 11901-2, VDI 3003	AGS350, TGS700, IGS150, PGS300, VV320-80, VV500, VV565	68	48	20.9	10	50	32.5	9	15	4	20
38	ISO 11901-2, VDI 3003	AGS500, TGS1000, IGS250, PGS500	74	54	23.9	16	54	38.5	9	15	4	20
45	ISO 11901-2, VDI 3003	AGS750, IGS500, LGS500, PGS750	80	60	27.5	22	60	45.5	9	15	4	20
50	ISO 11901-2, VDI 3003	AGS1000, AGS1200, TGS2000, IGS750, PGS1000, VV750	90	70	30	25	68	50.5	11	18	5	30
63 A	ISO 11901-2, VDI 3003	AGS1500, TGS3000, PGS1500	108	82	36.5	27	84	63.5	11	18	5	30
63 B	-	AGS1500, TGS3000, PGS1500	105	80	40	11	80	63	10.5	17	10	30
75	ISO 11901-2, VDI 3003	AGS2400, TGS5000, IGS1500, PGS2400, VV2385	125	94	42	32	100	75.5	13.5	20	5	30
95	ISO 11901-2, VDI 3003	AGS4200, TGS8000, IGS3000, PGS4200, VV2945	140	115	52.5	33	115	95.5	13.5	20	5	30
120	ISO 11901-2, VDI 3003	AGS6600, TGS12000, IGS5000, PGS6600	170	140	65	58	145	120.5	13.5	20	7	30
150	ISO 11901-2, VDI 3003	AGS9500, TGS20000, IGS7500, PGS9500	200	170	80	68	175	150.5	13.5	20	7	30

Fixing possibilities / Possibilités de fixation

MAX
0.5 x diameter of the gas spring body
0.5 x diamètre du corps du ressort à gaz

MIN
1/3 (one third) of dimension Lmin of the gas spring
1/3 (un tiers) de la dimension Lmin du ressort à gaz

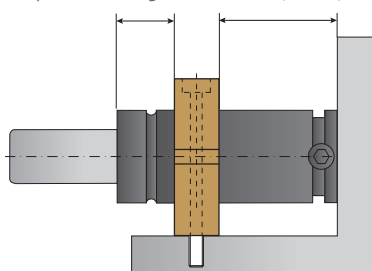

Dimension **MIN** must be respected to allow the over-pressure and over-stroke safety system to work properly (see dedicated catalogue section).

La dimension **MIN** doit être respectée pour permettre au système de sécurité en cas de surpression et de surcourse de fonctionner correctement (voir rubrique catalogue dédiée).

LINKED SYSTEM

AUTOMOTIVE LINE

Système lié

LINKED SYSTEM EXAMPLES

EXEMPLES DE SYSTÈMES LIÉS

With Ø5 mm hoses

Avec tuyaux de Ø5 mm

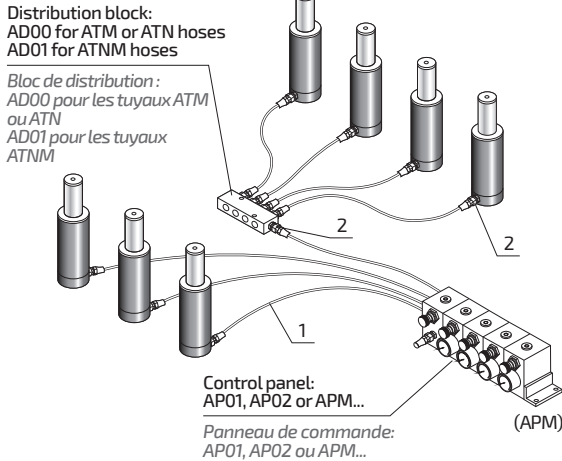

- 1 - Hoses ATM or ATN or ATNM / Tuyaux ATM ou ATN ou ATNM
2 - Fittings ARM (for hoses ATM) or ARN (for hoses ATN) or ARNM (for hoses ATNM)
Raccords ARM (pour tuyaux ATM) ou ARN (pour tuyaux ATN) ou ARNM (pour tuyaux ATNM)

With Ø8 mm hoses

Avec tuyaux de Ø8 mm

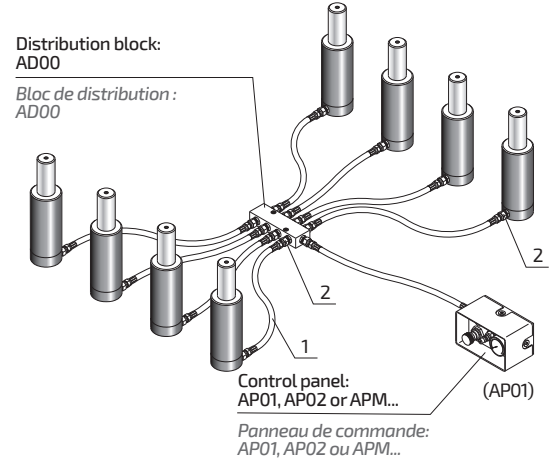

- 1 - Hoses AT / Tuyaux AT
2 - Fittings AR / Raccords AR

1 CHOOSE GAS SPRING MODEL CHOISIR MODÈLE À RESSORT À GAZ



Gas spring models Modèles de ressort à gaz	Side port Port latéral
AGS350-AGS2400 IGS150, IGS250 PGS300, PGS500 VV2385	M6
AGS4200-AGS20000 IGS500-IGS10000 LGS500 PGS750-PGS20000 VV750, VV2945	G1/8

2 CHOOSE HOSE MODEL CHOISIR MODÈLE DE TUYAU

For gas springs with M6 side port
Pour ressorts à gaz avec port latéral M6

For gas springs with G1/8 side port
Pour ressorts à gaz avec port latéral G1/8

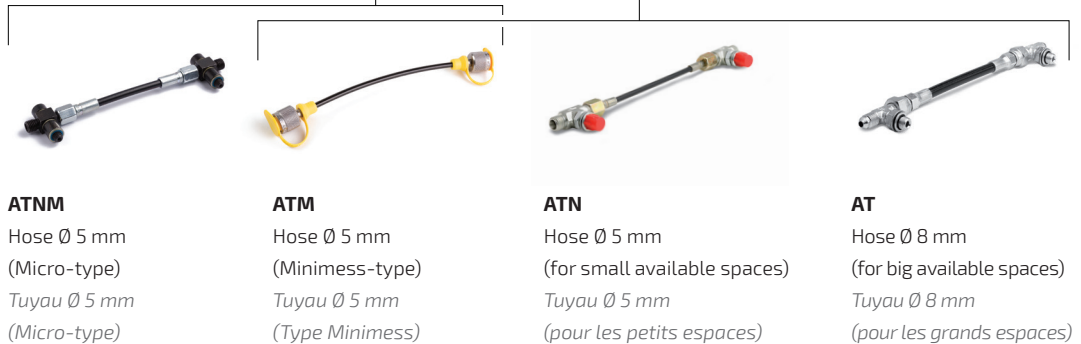

3 CHOOSE PROPER FITTINGS CHOISSER LES RACCORDS APPROPRIÉS



4

**CHOOSE CONTROL
PANEL MODEL**
*CHOISSIR LE MODÈLE
DE PANNEAU DE CONTRÔLE*



AP01
Standard
Standard



AP02
Compact
Compact



APM
Modular
Modulaire

... and other available models
... et autres modèles disponibles

5

**DISTRIBUTION BLOCKS
(IF NEEDED)**
*BLOCS DE DISTRIBUTION
(SI NÉCESSAIRE)*



AD01



AD00



AD04

... and other
available models
*... et autres modèles
disponibles*

6

**CONNECTING THE
GAS SPRINGS**
*CONNEXION DU
RESSORTS À GAZ*

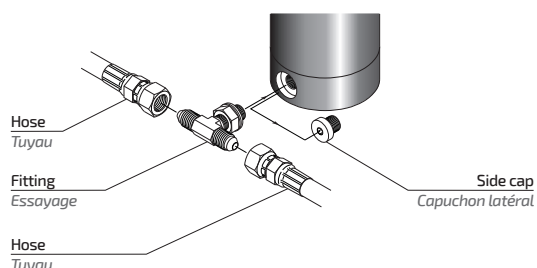

- ⚠ **ATTENTION!**
Follow the instructions on page 12 before connecting the gas springs
- ⚠ **ATTENTION!**
Suivez les instructions de la page 12 avant de connecter les ressorts à gaz

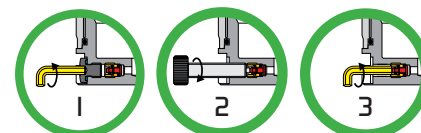

Discharge the gas spring and remove the valve before connecting to system
Décharger le vérin à gaz et retirez la valve avant de le connecter au système

7

**CHARGING AND
DISCHARGING**
*CHARGE ET
DÉCHARGE*



COMPL
Charging and discharging set
(also for self-contained gas springs)
*Kit de charge et de décharge
(également pour les ressorts à gaz
autonomes)*



CUC01
Charging unit
(also for self-contained gas springs)
included in the complete set COMPL
*Unité de charge
(également pour les ressorts à gaz
autonomes)
inclus dans le kit complet COMPL*



AN-1/4
Charging adapter for the quick
coupling on the control panels
*Adaptateur de charge pour
l'accouplement rapide sur les
panneaux de commande*

MINIMESS HOSES Ø 5 mm and FITTINGS

Tuyaux Ø 5 mm et raccords (type MINIMESS)

Flexible hose diameter 5 mm with fittings, for connecting nitrogen gas springs and many other devices.

Tuyau flexible diamètre 5 mm avec raccords, pour le raccordement de ressorts à gaz azoté et de nombreux autres appareils.

HOSE MECHANICAL SPECIFICATIONS

- Working temperature: -40 +100 °C
- Working pressure: max 630 bar
- Minimum bending radius: 20 mm
- Outside diameter: 5 mm

SPÉCIFICATIONS MÉCANIQUES DU TUYAU

- Température de fonctionnement : -40 +100 °C
- Pression de service : max 630 bar
- Rayon de courbure minimum : 20 mm
- Diamètre extérieur : 5 mm

TECHNICAL NOTES

Choose the proper hose length considering the "Assembly" indications.

NOTES TECHNIQUES

Choisissez la bonne longueur de tuyau en tenant compte des indications « Assemblage ».



Assembly / Assemblée

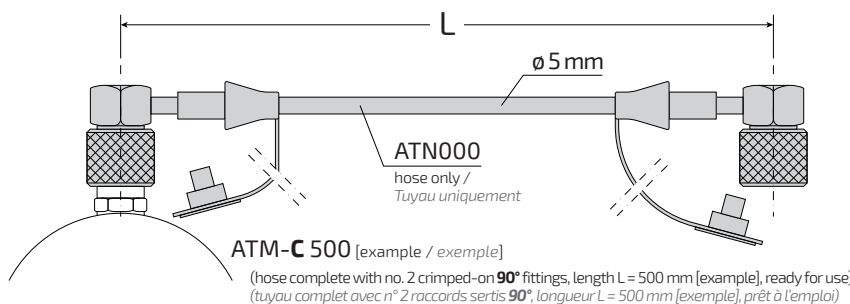
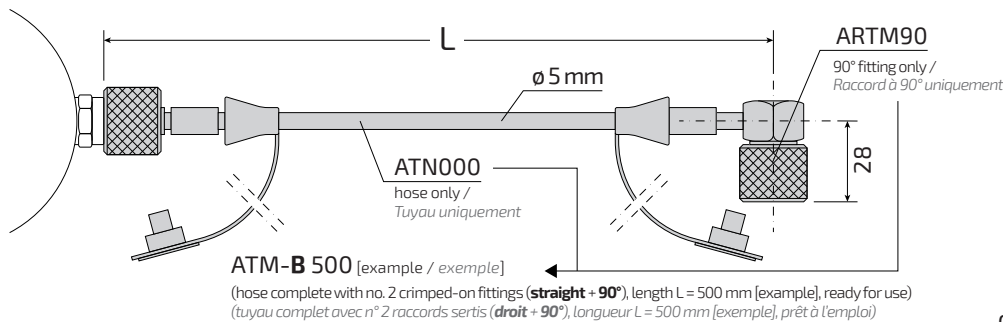
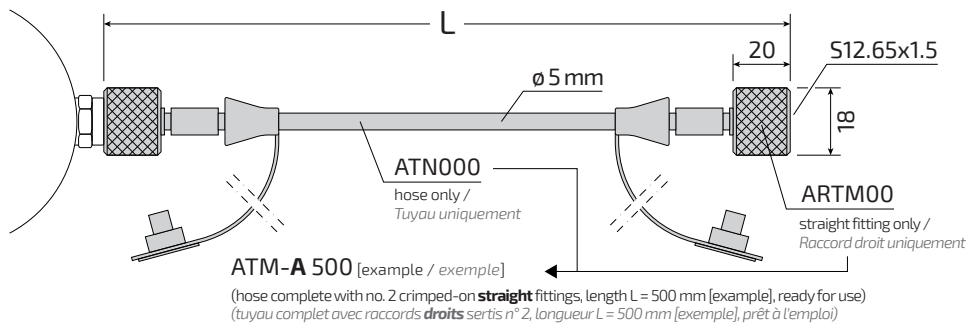
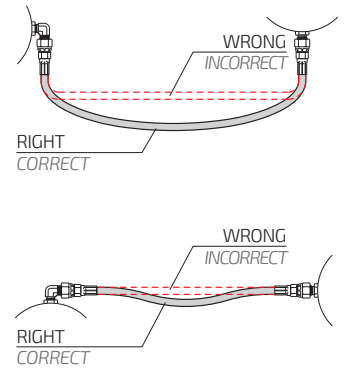

ORDER HOSE cod. ATN000 (quantity in metres, for example: "ATN000 10 m") and FITTINGS cod. ARTM00/ARTM90 for SELF-CUTTING and SELF-CRIMPING COMMANDER TUYAU COD. ATN000 (quantité en mètres, par exemple : « ATN000 10 m ») et LES RACCORDS cod. ARTM00/ARTM90 pour AUTO-COUCPE et AUTO-SERTISSAGE

LENGTH OF STANDARD HOSES, FITTINGS INCLUDED (Different lengths can be prepared on request - Minimum lengths: see "L MIN")

LONGUEUR DES TUYAUX STANDARD, RACCORDS INCLUS (Différentes longueurs peuvent être préparées sur demande - Longueurs minimales : voir « L MIN »)

Model Modèle	L mm	Model Modèle	L mm	Model Modèle	L mm	Models Modèles	L MIN* mm
ATM-... 150	150	ATM-... 400	400	ATM-... 1000	1000	ATM-A...	90
ATM-... 175	175	ATM-... 500	500	ATM-... 1500	1500	ATM-B...	95
ATM-... 200	200	ATM-... 600	600	ATM-... 2000	2000	ATM-C...	105
ATM-... 250	250	ATM-... 700	700				
ATM-... 300	300	ATM-... 800	800				
ATM-... 350	350	ATM-... 900	900				

* No plastic caps for L < 150 mm

* Pas de capuchons en plast. pour L < 150 mm

MINIMESS FITTINGS for ATM HOSES

Raccords pour tuyaux ATM (type MINIMESS)

FITTINGS FOR LINKING GAS SPRINGS, CONTROL PANELS AND DISTRIBUTION BLOCKS

RACCORDS POUR RELIER DES RESSORTS À GAZ, DES PANNEAUX DE COMMANDE ET DES BLOCS DE DISTRIBUTION

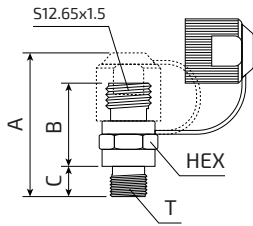

Model Modèle	A mm	B mm	C mm	T	HEX	Tightening torque Couple de serrage	Non-return valve Clapet anti-retour
ARM000-1/8	48	30	8	G1/8	14	ca. 18 Nm	NO
ARM000-1/8V	48	30	8	G1/8	14	ca. 18 Nm	YES
ARM000-1/4	43	21	12	G1/4	19	ca. 45 Nm	NO
ARM000-1/4V	43	21	12	G1/4	19	ca. 45 Nm	YES

⚠ ATTENTION! Use fittings **without** non-return valve when connecting gas springs and other devices to open system (hose system).
ATTENTION! Utilisez des raccords **sans** clapet anti-retour lors du raccordement de ressorts à gaz et d'autres dispositifs au système ouvert (système de tuyaux).

Model
Modèle

ARM270-M6

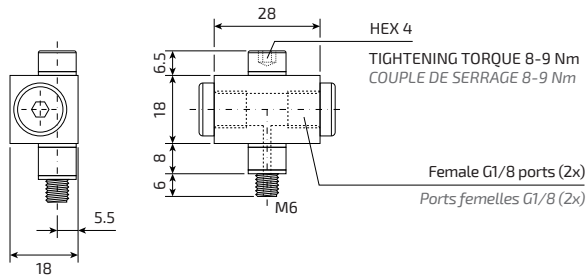

Model
Modèle

ARM270R-M6

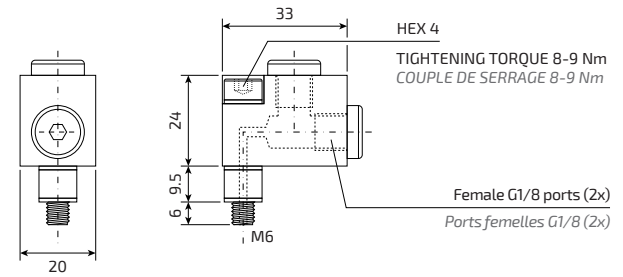

Model
Modèle

ARM270-1/8

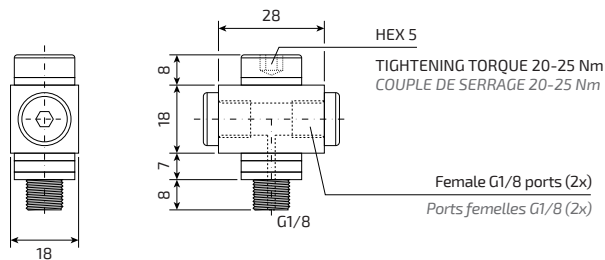

Model
Modèle

ARM090-1/8

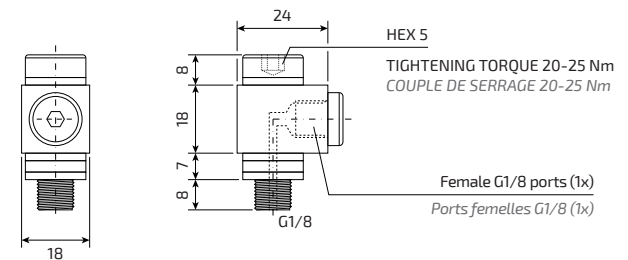

Extension fittings which may be needed in case of fixing with half-flanges
 Rallonges qui peuvent être nécessaires en cas de fixation avec des demi-brides



PL-M6

PL-1/8A

PL-1/8B

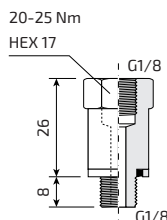
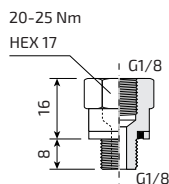
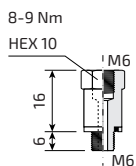

M6 to G1/8 side port converter
 Convertisseur de port latéral M6 vers G1/8

ARNMF

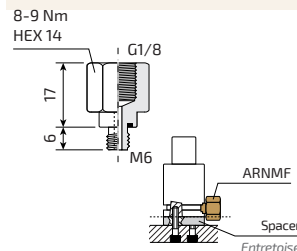

OTHER ACCESSORIES AUTRES ACCESSOIRES

Model
Modèle

CFT-5

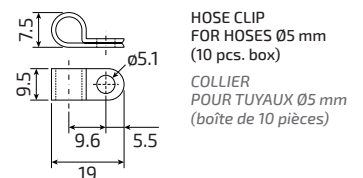

MICRO HOSES Ø 5 mm and FITTINGS

Tuyaux Ø 5 mm et raccords (type MICRO)



Flexible hose diameter 5 mm with fittings, for connecting nitrogen gas springs and many other devices.

Tuyau flexible diamètre 5 mm avec raccords, pour le raccordement de ressorts à gaz azoté et de nombreux autres appareils.

HOSE MECHANICAL SPECIFICATIONS

- Working temperature: -40 +100 °C
- Working pressure: max 630 bar
- Minimum bending radius: 20 mm
- Outside diameter: 5 mm

SPÉCIFICATIONS MÉCANIQUES DU TUYAU

- Température de fonctionnement : -40 +100 °C
- Pression de service : max 630 bar
- Rayon de courbure minimum : 20 mm
- Diamètre extérieur : 5 mm

TECHNICAL NOTES

Calculating hose length:

$L = (A - 20) \times 1.05$ (dimensions in millimetres)

L = Hose length (fittings included)

A = Distance between gas springs to be connected

NOTES TECHNIQUES

Calcul de la longueur du tuyau :

$L = (A - 20) \times 1.05$ (dimensions en millimètres)

L = Longueur du tuyau (raccords inclus)

A = Distance entre les ressorts à gaz à connecter

Assembly / Assemblée

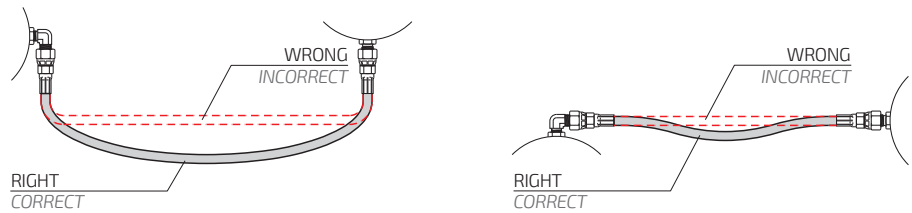

TIGHTENING TORQUE 8-9 Nm
COUPLE DE SERRAGE 8-9 Nm

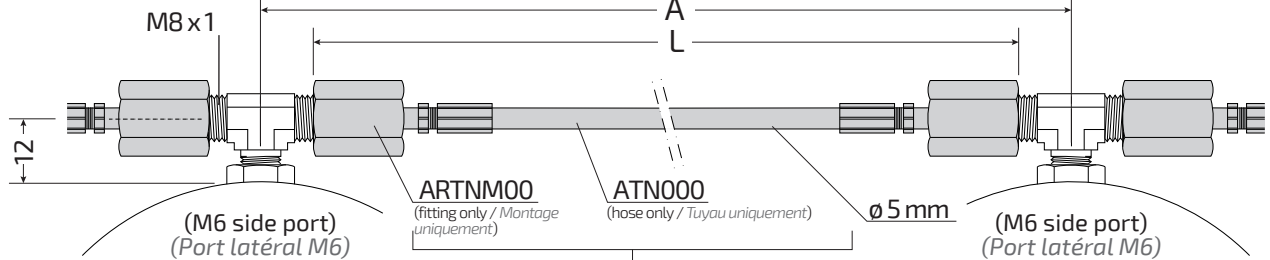

ATNM 500 [exemple / exemple]

(hose complete with no. 2 crimped-on fittings, length L = 500 mm [exemple], ready for use)
(tuyau complet avec n° 2 raccords sertis, longueur L = 500 mm [exemple], prêt à l'emploi)

ORDER HOSE cod. ATNM00 (quantity in metres, for example: "ATNM00 10 m") and FITTINGS cod. ARTNM00 for SELF-CUTTING and SELF-CRIMPING

COMMANDER LE TUYAU cod. ATNM00 (quantité en mètres, par exemple : « ATNM00 10 m ») et LES RACCORDS cod. ARTNM00 pour AUTO-COUCPE et AUTO-SERTISSAGE

LENGTH OF STANDARD HOSES, FITTINGS INCLUDED (Different lengths can be prepared on request - Minimum lengths L = 90 mm)

LONGUEUR DES TUYAUX STANDARD, RACCORDS INCLUS (Différentes longueurs peuvent être préparées sur demande - Longueurs minimales L = 90 mm)







Model Modèle	A mm	L mm	Model Modèle	A mm	L mm	Model Modèle	A mm	L mm
ATNM 100	115	100	ATNM 300	306	300	ATNM 800	782	800
ATNM 125	139	125	ATNM 350	353	350	ATNM 900	877	900
ATNM 150	163	150	ATNM 400	401	400	ATNM 1000	972	1000
ATNM 175	187	175	ATNM 500	496	500	ATNM 1500	1449	1500
ATNM 200	210	200	ATNM 600	591	600	ATNM 2000	1925	2000
ATNM 250	258	250	ATNM 700	687	700			

MICRO FITTINGS for ATNM HOSES

Raccords pour tuyaux ATNM (type MICRO)

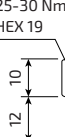
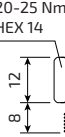
FITTINGS FOR LINKING GAS SPRINGS, CONTROL PANELS AND DISTRIBUTION BLOCKS

RACCORDS POUR RELIER DES RESSORTS À GAZ, DES PANNEAUX DE COMMANDE ET DES BLOCS DE DISTRIBUTION

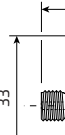
Model Modèle	Model Modèle	Model Modèle	Model Modèle
ARNM000	ARNM000CP	ARNM00P	ARNM00G
 <p>TIGHTENING TORQUE 8-9 Nm COUPLE DE SERRAGE 8-9 Nm</p>	 <p>TIGHTENING TORQUE 20-25 Nm COUPLE DE SERRAGE 20-25 Nm</p>	 <p>25-30 Nm HEX 19</p>	 <p>20-25 Nm HEX 14</p>
ARNM090	ARNM270	ARNM270R	ARNM360
 <p>TIGHTENING TORQUE 8-9 Nm COUPLE DE SERRAGE 8-9 Nm</p>	 <p>TIGHTENING TORQUE 8-9 Nm COUPLE DE SERRAGE 8-9 Nm</p>	 <p>TIGHTENING TORQUE 8-9 Nm COUPLE DE SERRAGE 8-9 Nm</p>	 <p>TIGHTENING TORQUE 8-9 Nm COUPLE DE SERRAGE 8-9 Nm</p>

Extension fittings which may be needed in case of fixing with half-flanges

Rallonges qui peuvent être nécessaires en cas de fixation avec des demi-brides



PL-M6

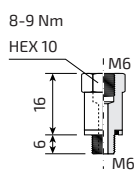

FITTINGS FOR HOSE-HOSE CONNECTION RACCORDS POUR RACCORDEMENT TUYAU-TUYAU

Model
Modèle

ARNM270T

Model
Modèle

ARNM360T

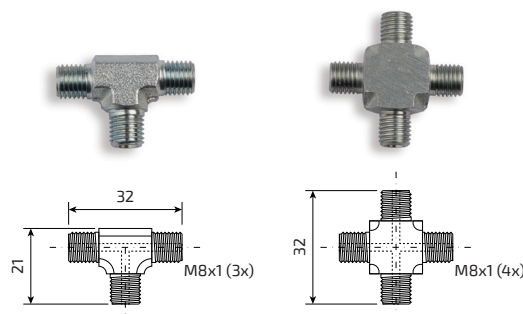

OTHER ACCESSORIES AUTRES ACCESSOIRES

Model
Modèle

CFT-5

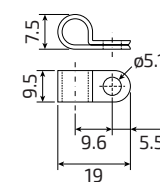

HOSE CLIP
FOR HOSES Ø5 mm
(10 pcs. box)
COLLIER
POUR TUYAUX Ø5 mm
(boîte de 10 pièces)

ATN

HOSES Ø 5 mm and FITTINGS

Tuyaux Ø 5 mm et raccords



Flexible hose diameter 5 mm with fittings, for connecting nitrogen gas springs and many other devices.

Tuyau flexible diamètre 5 mm avec raccords, pour le raccordement de ressorts à gaz azoté et de nombreux autres appareils.

HOSE MECHANICAL SPECIFICATIONS

- Working temperature: -40 +100 °C
- Working pressure: max 630 bar
- Minimum bending radius: 20 mm
- Outside diameter: 5 mm

SPÉCIFICATIONS MÉCANIQUES DU TUYAU

- Température de fonctionnement : -40 +100 °C
- Pression de service : max 630 bar
- Rayon de courbure minimum : 20 mm
- Diamètre extérieur : 5 mm

TECHNICAL NOTES

Calculating hose length:

$L = (A - 25) \times 1.05$ (dimensions in millimetres)

L = Hose length (fittings included)

A = Distance between gas springs to be connected

NOTES TECHNIQUES

Calcul de la longueur du tuyau :

$L = (A - 25) \times 1.05$ (dimensions en millimètres)

L = Longueur du tuyau (raccords inclus)

A = Distance entre les ressorts à gaz à connecter

Assembly / Assemblée

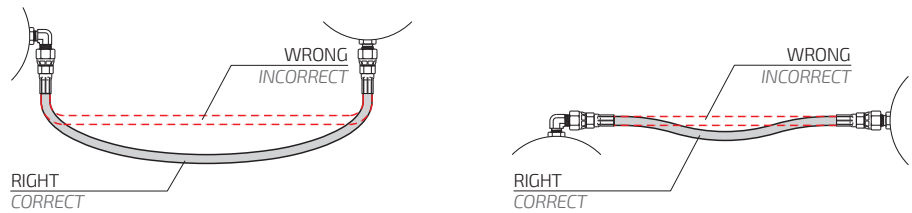

TIGHTENING TORQUE 16-18 Nm
COUPLE DE SERRAGE 16-18 Nm

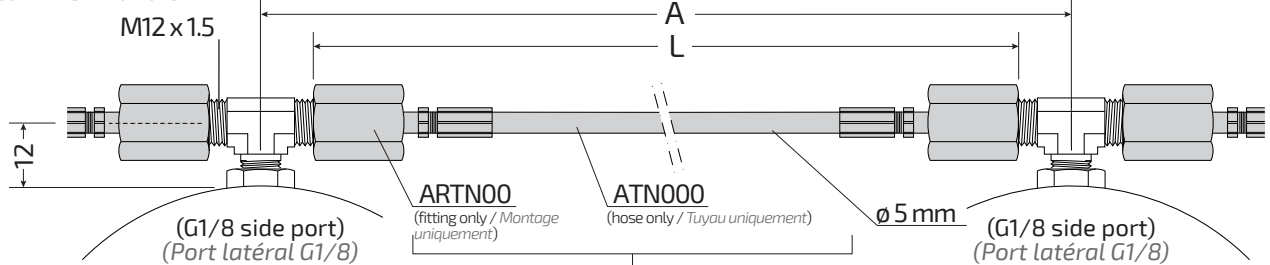

ATN 500 [exemple / exemple]

(hose complete with no. 2 crimped-on fittings, length L = 500 mm [exemple], ready for use)
(tuyau complet avec n° 2 raccords sertis, longueur L = 500 mm [exemple], prêt à l'emploi)

ORDER HOSE cod. ATN000 (quantity in metres, for example: "ATN000 10 m") and FITTINGS cod. ARTN00 for SELF-CUTTING and SELF-CRIMPING

COMMANDER LE TUYAU cod. ATN000 (quantité en mètres, par exemple : « ATN000 10 m ») et LES RACCORDS cod. ARTN00 pour AUTO-COUCPE et AUTO-SERTISSAGE

LENGTH OF STANDARD HOSES, FITTINGS INCLUDED (Different lengths can be prepared on request - Minimum lengths L = 90 mm)

LONGUEUR DES TUYAUX STANDARD, RACCORDS INCLUS (Différentes longueurs peuvent être préparées sur demande - Longueurs minimales L = 90 mm)

Model Modèle	A mm	L mm	Model Modèle	A mm	L mm	Model Modèle	A mm	L mm
ATN 100	120	100	ATN 300	311	300	ATN 800	787	800
ATN 125	144	125	ATN 350	358	350	ATN 900	882	900
ATN 150	168	150	ATN 400	406	400	ATN 1000	977	1000
ATN 175	192	175	ATN 500	501	500	ATN 1500	1454	1500
ATN 200	215	200	ATN 600	596	600	ATN 2000	1930	2000
ATN 250	263	250	ATN 700	692	700			

ARN

FITTINGS for ATN HOSES

Raccords pour tuyaux ATN

FITTINGS FOR LINKING GAS SPRINGS, CONTROL PANELS AND DISTRIBUTION BLOCKS

RACCORDS POUR RELIER DES RESSORTS À GAZ, DES PANNEAUX DE COMMANDE ET DES BLOCS DE DISTRIBUTION

Model
Modèle

ARN000

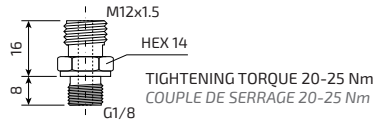

Model
Modèle

ARN090

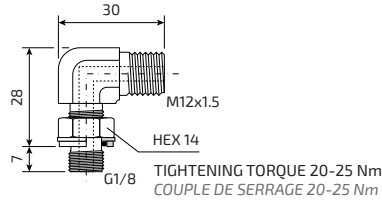

Model
Modèle

ARN045

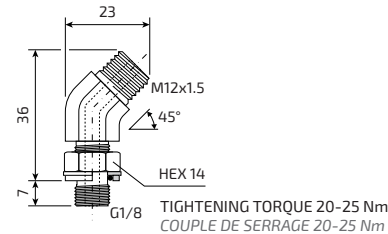
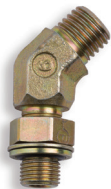

Extension fittings which may be needed in case of fixing with half-flanges

Rallonges qui peuvent être nécessaires en cas de fixation avec des demi-brides



FITTINGS FOR HOSE-HOSE CONNECTION

RACCORDS POUR RACCORDEMENT TUYAU-TUYAU

Model
Modèle

ARN270T

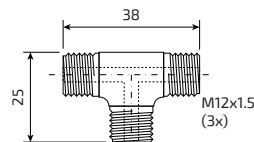
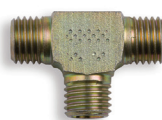

Model
Modèle

ARN360T

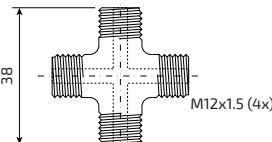

OTHER ACCESSORIES

AUTRES ACCESSOIRES

Model
Modèle

CFT-5

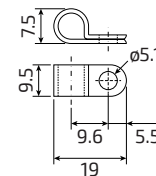

HOSE CLIP FOR HOSES Ø5 mm (10 pcs. box)
COLLIER POUR TUYAUX Ø5 mm (boîte de 10 pièces)

PL-1/8A

PL-1/8B

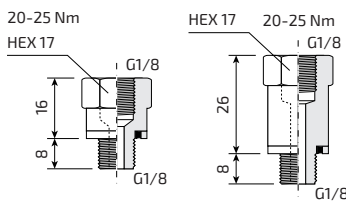

M6 to G1/8 side port converter
Convertisseur de port latéral M6 vers G1/8

ARNMF

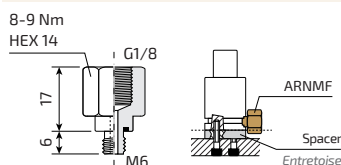

AT HOSES Ø 8 mm and FITTINGS

Tuyaux Ø 8 mm et raccords



Flexible hose diameter 8 mm with fittings, for connecting nitrogen gas springs and many other devices.

Tuyau flexible diamètre 8 mm avec raccords, pour le raccordement de ressorts à gaz azoté et de nombreux autres appareils.

HOSE MECHANICAL SPECIFICATIONS

- Working temperature: -40 +100 °C
- Working pressure: max 630 bar
- Minimum bending radius: 40 mm
- Outside diameter: 8 mm

SPÉCIFICATIONS MÉCANIQUES DU TUYAU

- Température de fonctionnement : -40 +100 °C
- Pression de service : max 630 bar
- Rayon de courbure minimum : 40 mm
- Diamètre extérieur : 8 mm

TECHNICAL NOTES

Calculating hose length:

$L = (A - 25) \times 1.05$ (dimensions in millimetres)

L = Hose length (fittings included)

A = Distance between gas springs to be connected

NOTES TECHNIQUES

Calcul de la longueur du tuyau :

$L = (A - 25) \times 1.05$ (dimensions en millimètres)

L = Longueur du tuyau (raccords inclus)

A = Distance entre les ressorts à gaz à connecter

Assembly / Assemblée

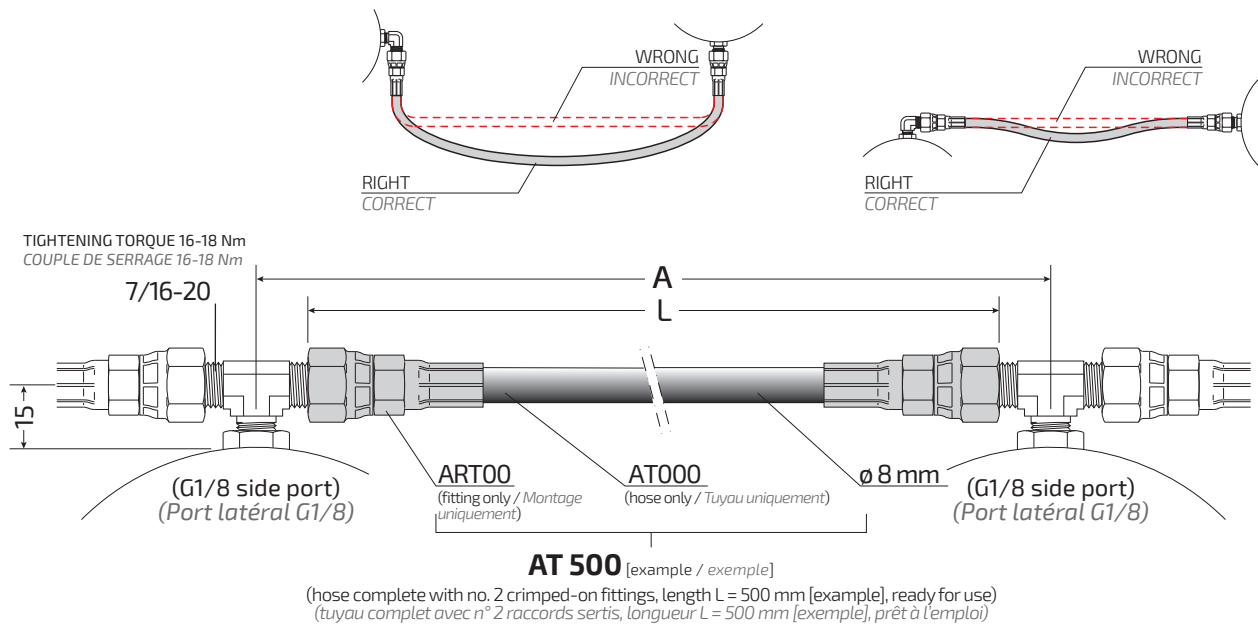

ORDER HOSE cod. AT000 (quantity in metres, for example: "AT000 10 m") and FITTINGS cod. ART00 for SELF-CUTTING and SELF-CRIMPING
COMMANDER TUYAU COD. AT000 (quantité en mètres, par exemple : « AT000 10 m ») et FITTINGS cod. ART00 pour l'AUTO-COUPÉ et l'AUTO-SERTISSAGE

LENGTH OF STANDARD HOSES, FITTINGS INCLUDED (Different lengths can be prepared on request - Minimum length L = 125 mm)

LONGUEUR DES TUYAUX STANDARD, RACCORDS INCLUS (Différentes longueurs peuvent être préparées sur demande - Longueur minimale L = 125 mm)

Model Modèle	A mm	L mm	Model Modèle	A mm	L mm	Model Modèle	A mm	L mm
-	-	-	AT 300	311	300	AT 800	787	800
AT 125	144	125	AT 350	358	350	AT 900	882	900
AT 150	168	150	AT 400	406	400	AT 1000	977	1000
AT 175	192	175	AT 500	501	500	AT 1500	1454	1500
AT 200	215	200	AT 600	596	600	AT 2000	1930	2000
AT 250	263	250	AT 700	692	700			

AR FITTINGS for AT HOSES

Raccords pour tuyaux AT

FITTINGS FOR LINKING GAS SPRINGS, CONTROL PANELS AND DISTRIBUTION BLOCKS

RACCORDS POUR RELIER DES RESSORTS À GAZ, DES PANNEAUX DE COMMANDE ET DES BLOCS DE DISTRIBUTION

Model
Modèle

AR000



Model
Modèle

AR090



Model
Modèle

AR045



Extension fittings which may be needed in case of fixing with half-flanges

Rallonges qui peuvent être nécessaires en cas de fixation avec des demi-brides



PL-1/8A

PL-1/8B

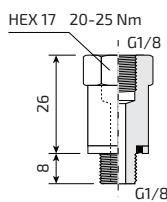
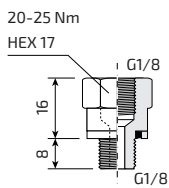

M6 to G1/8 side port converter
Convertisseur de port latéral M6 vers G1/8

ARNMF

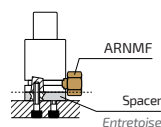
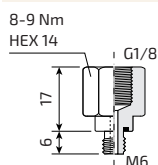

Model
Modèle

AR000-1/4

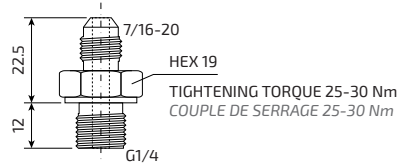

Model
Modèle

AR270R



Model
Modèle

AR270

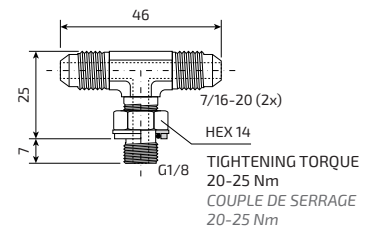
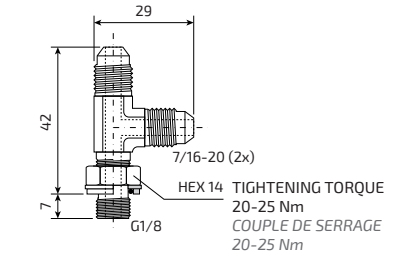

FITTINGS FOR HOSE-HOSE CONNECTION

RACCORDS POUR RACCORDEMENT TUYAU-TUYAU

Model
Modèle

AR270T

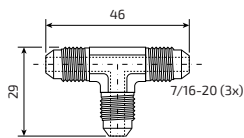

Model
Modèle

AR360T

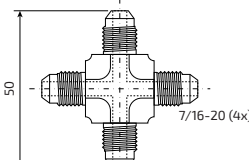
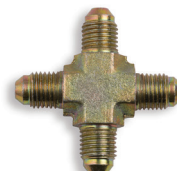

OTHER ACCESSORIES

AUTRES ACCESSOIRES

Model
Modèle

CFT-8

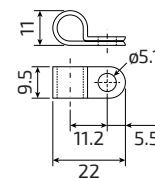

HOSE CLIP FOR HOSES Ø8 mm (10 pcs. box)
COLLIER POUR TUYAUX Ø8 mm (boîte de 10 pièces)

AP01CV / AP01 CONTROL PANEL

Panneau de commande AP01CV / AP01



This panel allows to charge and discharge a nitrogen gas spring or a nitrogen gas springs system, and to monitor the pressure.

Ce panneau permet de charger et de décharger un ressort à gaz azoté ou un système de ressorts à gaz, et de surveiller la pression.

TECHNICAL NOTES

NOTES TECHNIQUES

- A** **Charging valve:**
- **AP01CV:** CEJN-type, compatible with most non-Bordignon charging systems
 - **AP01:** Bordignon-standard, to be used only with CUC01 or COMPL or BOOSTER
- B** Discharging valve
C Pressure gauge
D No. 3 connection ports (G1/8)
E Plug ready for safety pressure switch
F No. 2 fixing holes for M6 hex-socket screws
- G** The connection ports are plugged
- ATTENTION! USE NITROGEN N₂ ONLY**

- A** **Valve de charge:**
- **AP01CV:** Type CEJN, compatible avec la plupart des systèmes de charge non Bordignon
 - **AP01:** Standard Bordignon, à utiliser uniquement avec CUC01, COMPL ou BOOSTER
- B** Vanne de décharge
C Manomètre
D N° 3 ports de connexion (G1/8)
E Fiche prête pour pressostat de sécurité
F N° 2 trous de fixation pour vis à six pans hexagonaux M6
G Les ports de connexion sont bouchés
- ATTENTION! N'UTILISEZ QUE DE L'AZOTE N₂**

Most used
Le plus utilisé

AP01CV CEJN 10 358

AP01 Bordignon-standard
Standard Bordignon

Dimensions / Taille

APR01AN pressure switch installed here if required (see available models)

APR01AN pressostat installé ici si nécessaire (voir les modèles disponibles)

Overpressure rupture plug installed here if required (see available models)
Bouchon de rupture de surpression installé ici si nécessaire (voir les modèles disponibles)

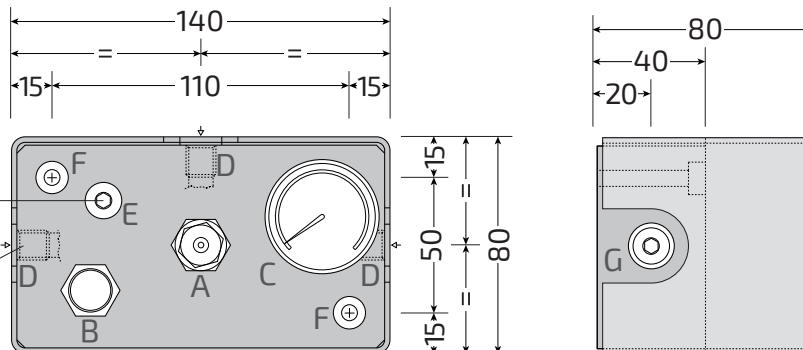

Model Modèle	Model Modèle	
AP01CV	AP01	Control panel Panneau de commande
AP01PANCV	AP01PAN	Control panel with APR01AN pressure switch (50-300 bar normally open) Panneau de commande avec pressostat APR01AN (50-300 bar normalement ouvert)
AP01RPCV	AP01RP	Control panel with overpressure rupture plug Panneau de commande avec bouchon de rupture de surpression
AP01FCV	AP01F	Control panel with APR01AN pressure switch (50-300 bar normally open) and with overpressure rupture plug Panneau de commande avec pressostat APR01AN (50-300 bar normalement ouvert) et avec bouchon de rupture de surpression



Add "LOCK" after the control panel code to receive it with lockable discharging valve for Lockout-Tagout applications. Order padlock (code: PADLOCK) separately (also usable with BRADY part no. 850821 padlock). Example: "AP01FLOCK" = control panel AP01F with lockable discharging valve.
Ajoutez «LOCK» après le code du panneau de commande pour le recevoir avec une soupape de décharge verrouillable pour les applications Lockout-Tagout. Commandez le cadenas (code : PADLOCK) séparément (également utilisable avec le cadenas BRADY réf. 850821). Exemple : «AP01FLOCK» = panneau de commande AP01F avec soupape de décharge verrouillable.

All models are available with safety valve VS500 already assembled (on request). / Tous les modèles sont disponibles avec la soupape de sécurité VS500 déjà montée (sur demande).

APO2CV / APO2

CONTROL PANEL (COMPACT)

Panneau de commande APO2CV / APO2 (compact)



This compact panel allows to charge and discharge a nitrogen gas spring or a nitrogen gas springs system, and to monitor the pressure.

Ce panneau compact permet de charger et de décharger un ressort à gaz azoté ou un système de ressorts à gaz azotés, et de surveiller la pression.

TECHNICAL NOTES

NOTES TECHNIQUES

A Charging valve:

- **APO2CV:** CEJN-type, compatible with most non-Bordignon charging systems
- **APO2:** Bordignon-standard, to be used only with CUC01 or COMPL or BOOSTER

A Valve de charge:

- **APO2CV:** Type CEJN, compatible avec la plupart des systèmes de charge non Bordignon
- **APO2:** Standard Bordignon, à utiliser uniquement avec CUC01, COMPL ou BOOSTER

B Discharging valve

B Vanne de décharge

C Pressure gauge

C Manomètre

- No. 2 fixing holes for M5 hex-socket screws

- N° 2 trous de fixation pour vis à six pans hexagonaux M5

- No. 5 connection ports (G1/8)
- The connection ports are plugged

- N° 5 ports de connexion (G1/8)
- Les ports de connexion sont bouchés

 ATTENTION! USE NITROGEN N₂ ONLY

 ATTENTION! N'UTILISEZ QUE DE L'AZOTE N₂

Most used
Le plus utilisé

APO2CV



CEJN 10 358

APO2



Bordignon-standard
Standard Bordignon

Dimensions / Taille

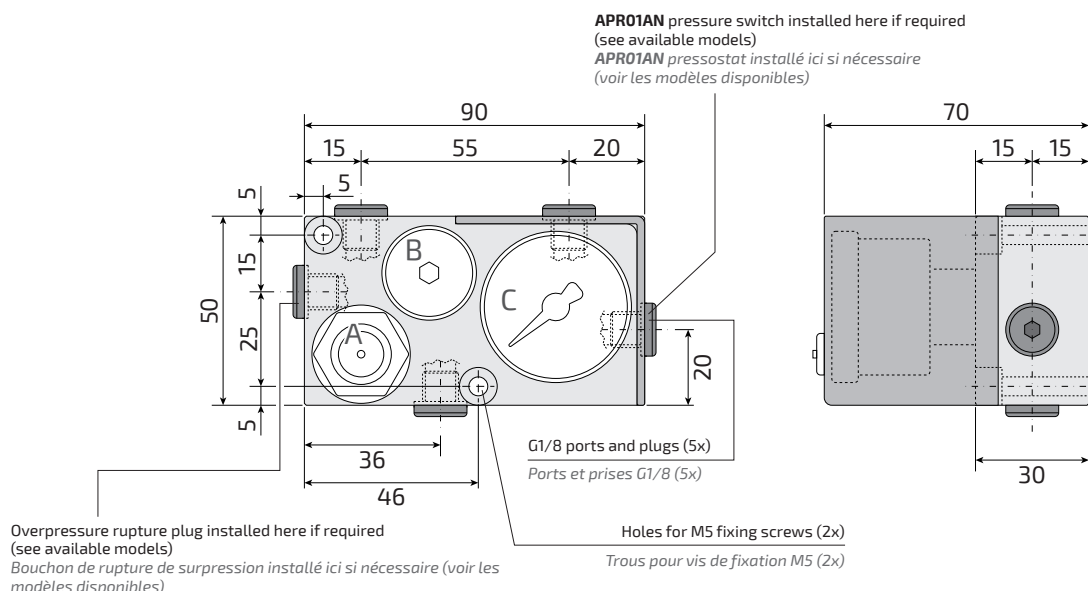

Model Modèle	Model Modèle	
APO2CV	APO2	Control panel (compact version) Panneau de commande (version compacte)
APO2PANCV	APO2PAN	Control panel (compact version) with APR01AN pressure switch (50-300 bar normally open) Panneau de commande (version compacte) avec pressostat APR01AN (50-300 bar normalement ouvert)
APO2RPCV	APO2RP	Control panel (compact version) with overpressure rupture plug Panneau de commande (version compacte) avec bouchon de rupture de surpression
APO2FCV	APO2F	Control panel (compact version) with APR01AN pressure switch (50-300 bar normally open) and with overpressure rupture plug Panneau de commande (version compacte) avec pressostat APR01AN (50-300 bar normalement ouvert) et avec bouchon de rupture de surpression

All models are available with safety valve VS500 already assembled (on request). / Tous les modèles sont disponibles avec la soupape de sécurité VS500 déjà montée (sur demande).

AP04CV / AP04 CONTROL PANEL

AUTOMOTIVE LINE

Panneau de commande AP04CV / AP04



This panel allows to charge and discharge a nitrogen gas spring or a nitrogen gas springs system, and to monitor the pressure.

Ce panneau permet de charger et de décharger un ressort à gaz azoté ou un système de ressorts à gaz, et de surveiller la pression.

TECHNICAL NOTES

- A**  **Charging valve:**
- **AP04CV:** CEJN-type, compatible with most non-Bordignon charging systems
 - **AP04:** Bordignon-standard, to be used only with CUC01 or COMPL or BOOSTER
- B** Discharging valve
- C** Pressure gauge
- D** No. 1 connection port G1/4 **
- E** No. 7 connection ports G1/8
- The connection ports are plugged
 - No. 2 fixing holes for M10 hex-socket screws

 **ATTENTION! USE NITROGEN N₂ ONLY**

NOTES TECHNIQUES

- A**  **Valve de charge:**
- **AP04CV:** Type CEJN, compatible avec la plupart des systèmes de charge non Bordignon
 - **AP04:** Standard Bordignon, à utiliser uniquement avec CUC01, COMPL ou BOOSTER
- B** Vanne de décharge
- C** Manomètre
- D** N° 1 port de connexion G1/4 **
- E** N° 7 ports de connexion G1/8
- Les ports de connexion sont bouchés
 - N° 2 trous de fixation pour vis à six pans hexagonaux M10

 **ATTENTION! N'UTILISEZ QUE DE L'AZOTE N₂**

Most used
Le plus utilisé

AP04CV



CEJN 10 358

AP04



Bordignon-standard
Standard Bordignon

Dimensions / Taille

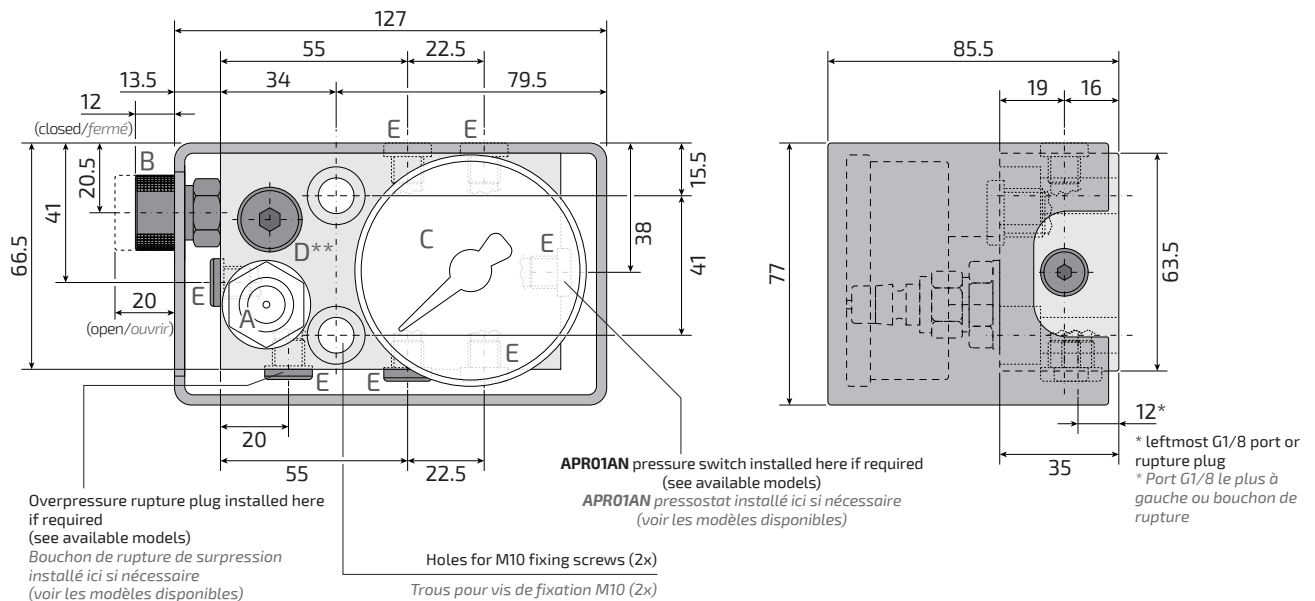

** NOTE: for the AP04CV models, the CEJN-type charging valve will not allow the connection of safety switches or safety valves on the front G1/4 port (port "D" on the drawing above).

** REMARQUE: pour les modèles AP04CV, la soupape de charge de type CEJN ne permettra pas le raccordement d'interrupteurs de sécurité ou de soupapes de sécurité sur l'orifice « D » sur le dessin ci-dessus).

Model Modèle	Model Modèle	
AP04CV	AP04	Control panel Panneau de commande
AP04PANCV	AP04PAN	Control panel with APR01AN pressure switch (50-300 bar normally open) Panneau de commande avec pressostat APR01AN (50-300 bar normalement ouvert)
AP04RPCV	AP04RP	Control panel with overpressure rupture plug Panneau de commande avec bouchon de rupture de surpression
AP04FCV	AP04F	Control panel with APR01AN pressure switch (50-300 bar normally open) and with overpressure rupture plug Panneau de commande avec pressostat APR01AN (50-300 bar normalement ouvert) et avec bouchon de rupture de surpression

All models are available with safety valve VS500 already assembled (on request). / Tous les modèles sont disponibles avec la soupape de sécurité VS500 déjà montée (sur demande).

AP05CV / AP05 CONTROL PANEL

AUTOMOTIVE LINE

Panneau de commande AP05CV / AP05



This panel allows to charge and discharge a nitrogen gas spring or a nitrogen gas springs system, and to monitor the pressure.

Ce panneau permet de charger et de décharger un ressort à gaz azoté ou un système de ressorts à gaz, et de surveiller la pression.

TECHNICAL NOTES

- A** **Charging valve:**
- **AP05CV:** CEJN-type, compatible with most non-Bordignon charging systems
 - **AP05:** Bordignon-standard, to be used only with CUC01 or COMPL or BOOSTER
- B** Discharging valve
- C** Pressure gauge
- D** No. 9 connection ports G1/4
- E** No. 1 connection port G1/8
- The connection ports are plugged
 - No. 2 fixing holes for M8 hex-socket screws
- Shut off valve for protecting the pressure gauge from pulsating pressure during operation

ATTENTION! USE NITROGEN N₂ ONLY

NOTES TECHNIQUES

- A** **Valve de charge:**
- **AP05CV:** Type CEJN, compatible avec la plupart des systèmes de charge non Bordignon
 - **AP05:** Standard Bordignon, à utiliser uniquement avec CUC01, COMPL ou BOOSTER
- B** Vanne de décharge
- C** Manomètre
- D** N° 9 ports de connexion G1/4
- E** N° 1 port de connexion G1/8
- Les ports de connexion sont bouchés
 - N° 2 trous de fixation pour vis à six pans hexagonaux M8
- Vanne d'arrêt pour protéger le manomètre des pressions pulsées pendant le fonctionnement

ATTENTION! N'UTILISEZ QUE DE L'AZOTE N₂

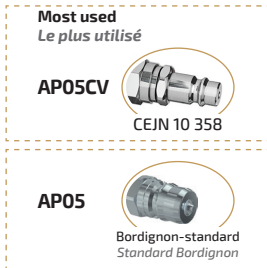

Dimensions / Taille

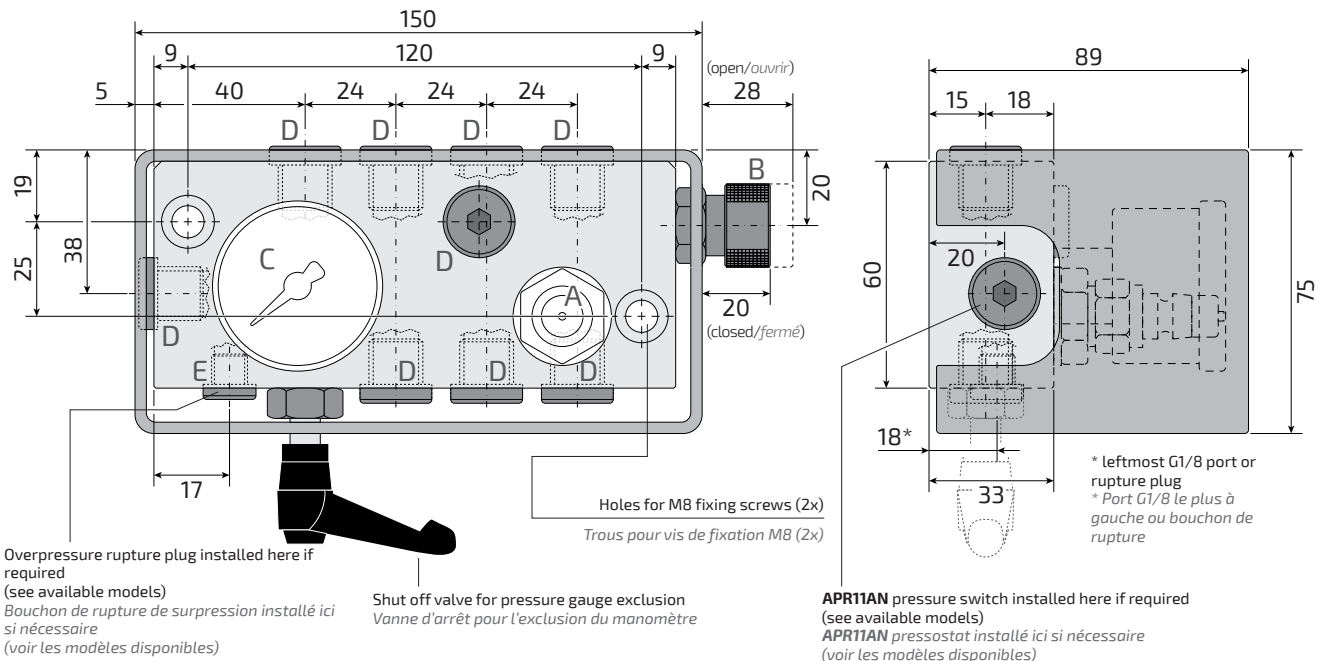

Model Modèle	Model Modèle	
AP05CV	AP05	Control panel Panneau de commande
AP05PANCV	AP05PAN	Control panel with APR11AN pressure switch (50-300 bar normally open) Panneau de commande avec pressostat APR11AN (50-300 bar normalement ouvert)
AP05RPCV	AP05RP	Control panel with overpressure rupture plug Panneau de commande avec bouchon de rupture de surpression
AP05FCV	AP05F	Control panel with APR11AN pressure switch (50-300 bar normally open) and with overpressure rupture plug Panneau de commande avec pressostat APR11AN (50-300 bar normalement ouvert) et avec bouchon de rupture de surpression

All models are available with safety valve VS500 already assembled (on request). / Tous les modèles sont disponibles avec la soupape de sécurité VS500 déjà montée (sur demande).

AP06CV / AP06

CONTROL PANEL (MICRO-TYPE PORTS)

AP06CV / AP06 Panneau de commande (ports de type MICRO)





This panel allows to charge and discharge a nitrogen gas spring or a nitrogen gas springs system, and to monitor the pressure.

Ce panneau permet de charger et de décharger un ressort à gaz azoté ou un système de ressorts à gaz, et de surveiller la pression.

TECHNICAL NOTES

NOTES TECHNIQUES

- A**  **Charging valve:**
- **AP06CV:** CEJN-type, compatible with most non-Bordignon charging systems
 - **AP06:** Bordignon-standard, to be used only with CUC01 or COMPL or BOOSTER
- B** Discharging valve
C Pressure gauge
D No. 1 connection port G1/4
E No. 1 connection port G1/8
F No. 15 connection ports M6 (5x top, 5x bottom, 5x rear)
- The connection ports are plugged
 - No. 6 (4x + 2x) fixing holes for M6 hex-socket screws

- A**  **Valve de charge:**
- **AP06CV:** Type CEJN, compatible avec la plupart des systèmes de charge non Bordignon
 - **AP06:** Standard Bordignon, à utiliser uniquement avec CUC01, COMPL ou BOOSTER
- B** Vanne de décharge
C Manomètre
D N° 1 port de connexion G1/4
E N° 1 port de connexion G1/8
F N° 15 ports de connexion M6 (5x en haut, 5x en bas, 5x à l'arrière)
- Les ports de connexion sont bouchés
 - N° 6 (4x + 2x) trous de fixation pour vis à six pans creux hexagonaux M6

 **ATTENTION! USE NITROGEN N₂ ONLY**

 **ATTENTION! N'UTILISEZ QUE DE L'AZOTE N₂**

Most used
Le plus utilisé

AP06CV



CEJN 10 358

AP06



Bordignon-standard
Standard Bordignon

Dimensions / Taille

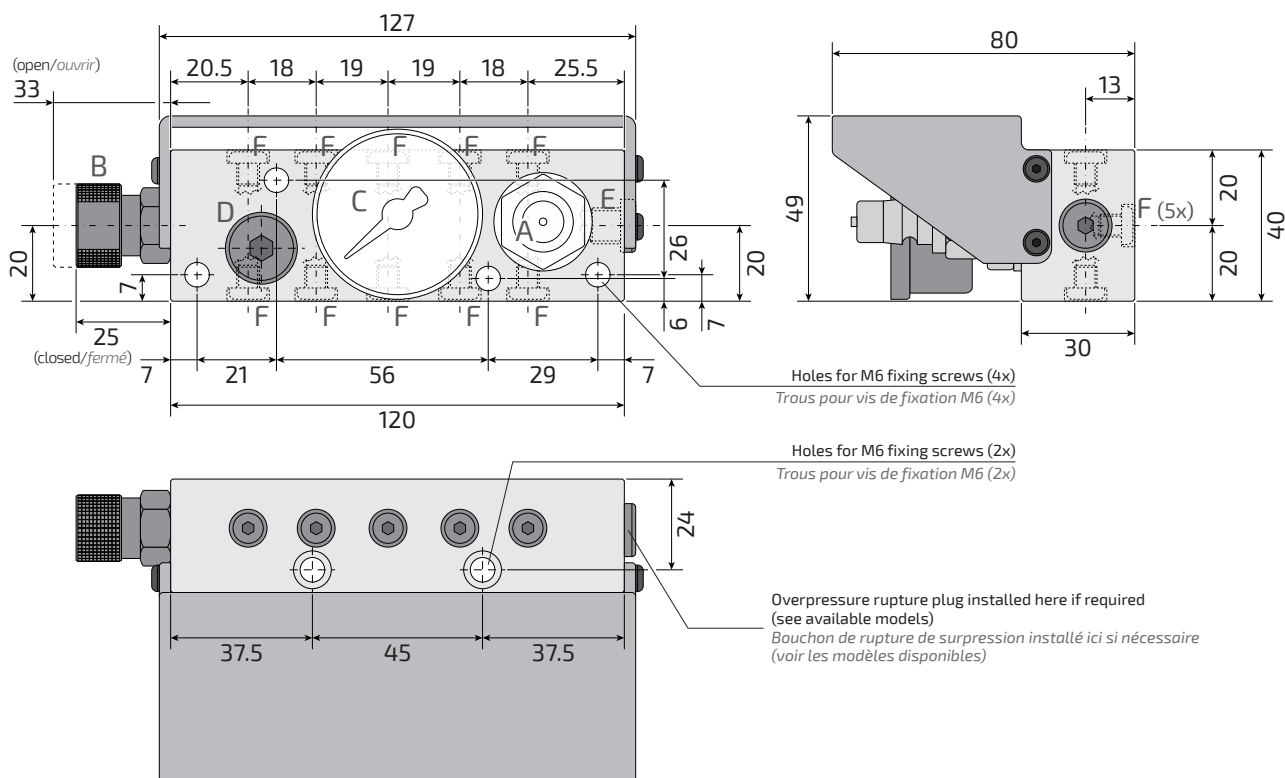

Model Modèle	Model Modèle	
AP06CV	AP06	Control panel (MICRO-type ports) Panneau de commande (ports de type MICRO)
AP06RPCV	AP06RP	Control panel (MICRO-type ports) with overpressure rupture plug Panneau de commande (ports de type MICRO) avec bouchon de rupture de surpression

APM...CV / APM... MODULAR CONTROL PANEL

Panneau de contrôle modulaire APM...CV / APM...

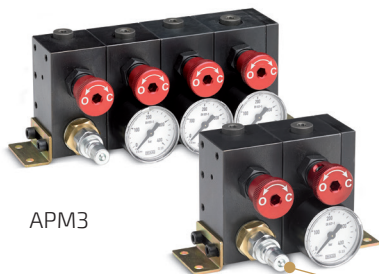

APM3

APM1

This panel allows to charge and discharge a nitrogen gas spring, or a nitrogen gas springs system, or multiple independent nitrogen gas springs systems, and to monitor the pressure. Each module can be charged at a different pressure.

Ce panneau permet de charger et de décharger un ressorts à gaz à l'azote, ou un système de ressorts à gaz à l'azote, ou plusieurs systèmes indépendants de ressorts à gaz à l'azote, et de surveiller la pression. Chaque module peut être chargé à une pression différente.

TECHNICAL NOTES

NOTES TECHNIQUES

- A** **Charging valve:**
 - **APM...CV:** CEJN-type, compatible with most non-Bordignon charging systems
 - **APM...:** Bordignon-standard, to be used only with CUC01 or COMPL or BOOSTER
- B** Discharging valve
- C** M5 fixing hole
- D** Single-module charging or discharging valve (always turned off during use)
- E** Connection ports (G1/8)
- F** Each module may be connected with more nitrogen gas springs.

- A** **Valve de charge:**
 - **APM...CV:** Type CEJN, compatible avec la plupart des systèmes de charge non Bordignon
 - **APM...:** Standard Bordignon, à utiliser uniquement avec CUC01, COMPL ou BOOSTER
- B** Vanne de décharge
- C** Trou de fixation M5
- D** Vanne de charge ou de décharge à module unique (toujours éteinte pendant l'utilisation)
- E** Ports de connexion (G1/8)
- F** Chaque module peut être connecté avec plus de ressorts à gaz d'azote.

**Most used
Le plus utilisé**

APM...CV
CEJN 10 358

APM...
Bordignon-standard
Standard Bordignon

It allows to check the pressure of each module separately.
No limit as to the quantity of connectible modules.

Il permet de vérifier la pression de chaque module séparément.
Aucune limite quant à la quantité de modules connectables.

ATTENTION! USE NITROGEN N₂ ONLY

ATTENTION! N'UTILISEZ QUE DE L'AZOTE N₂

Dimensions / Taille

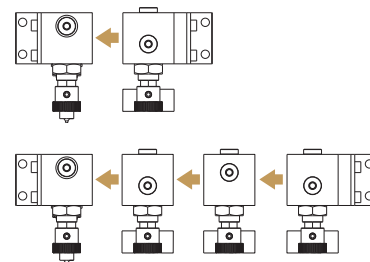
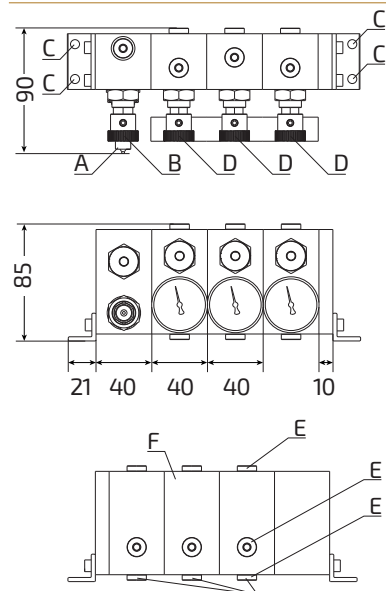

Overpressure rupture plugs (one for each module) installed here if required (see available models)
Bouchons de rupture de surpression (un pour chaque module) installé ici si nécessaire (voir les modèles disponibles)

Model Modèle	Model Modèle	Model Modèle	Model Modèle	Model Modèle	
APM1CV	APM1	Control panel with 1 module Panneau de commande avec 1 module	APM1RPCV	APM1RP	Control panel with 1 module, with overpressure rupture plug Panneau de commande avec 1 module, avec bouchon de rupture de surp.
APM2CV	APM2	Control panel with 2 modules Panneau de commande avec 2 modules	APM2RPCV	APM2RP	Control panel with 2 modules, with 2 pcs. overpressure rupture plugs Panneau de commande avec 2 modules, avec 2 pcs. bouchons de rupture de surp.
APM3CV	APM3	Control panel with 3 modules Panneau de commande avec 3 modules	APM3RPCV	APM3RP	Control panel with 3 modules, with 3 pcs. overpressure rupture plugs Panneau de commande avec 3 modules, avec 3 pcs. bouchons de rupture de surp.
APM4CV	APM4	Control panel with 4 modules Panneau de commande avec 4 modules	APM4RPCV	APM4RP	Control panel with 4 modules, with 4 pcs. overpressure rupture plugs Panneau de commande avec 4 modules, avec 4 pcs. bouchons de rupture de surp.
APM...CV	APM...	Control panel with ... modules Panneau de commande avec ... Modules	APM...RPCV	APM...RP	Control panel with ... modules, with ... pcs. overpressure rupture plugs Panneau de commande avec ... modules, avec ... pcs. bouchons de rupture de surp.

ASSEMBLY SCHEME / SCHEMA D'ASSEMBLAGE

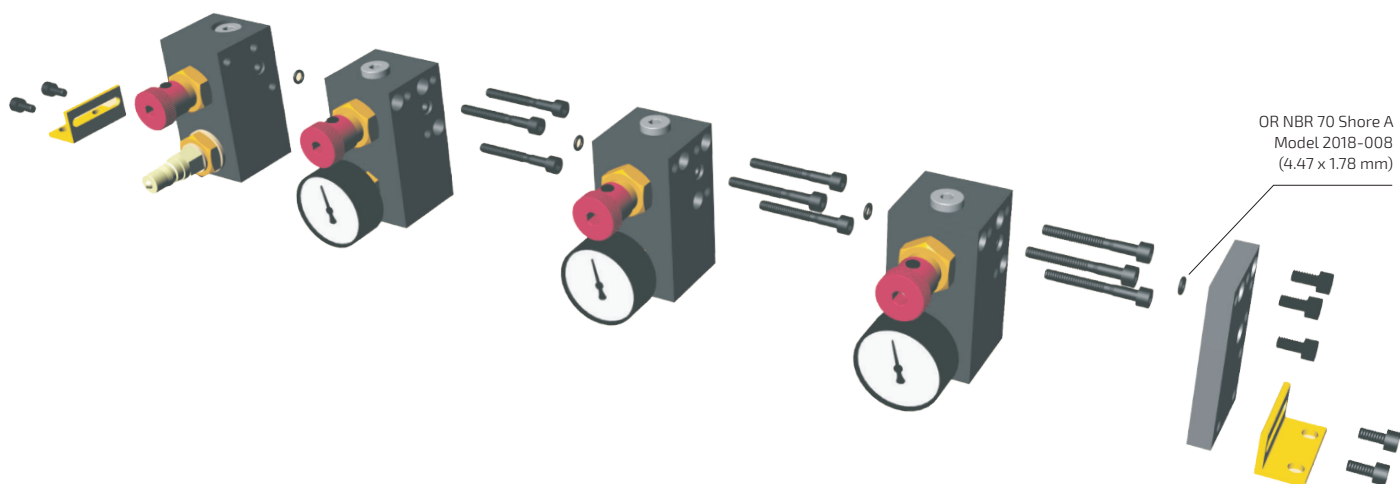

VARIOUS POSSIBILITIES FOR CONNECTING THE NITROGEN GAS SPRINGS / DIVERSES POSSIBILITES DE RACCORDEMENT DES RESSORTS A GAZ A LAZOTE

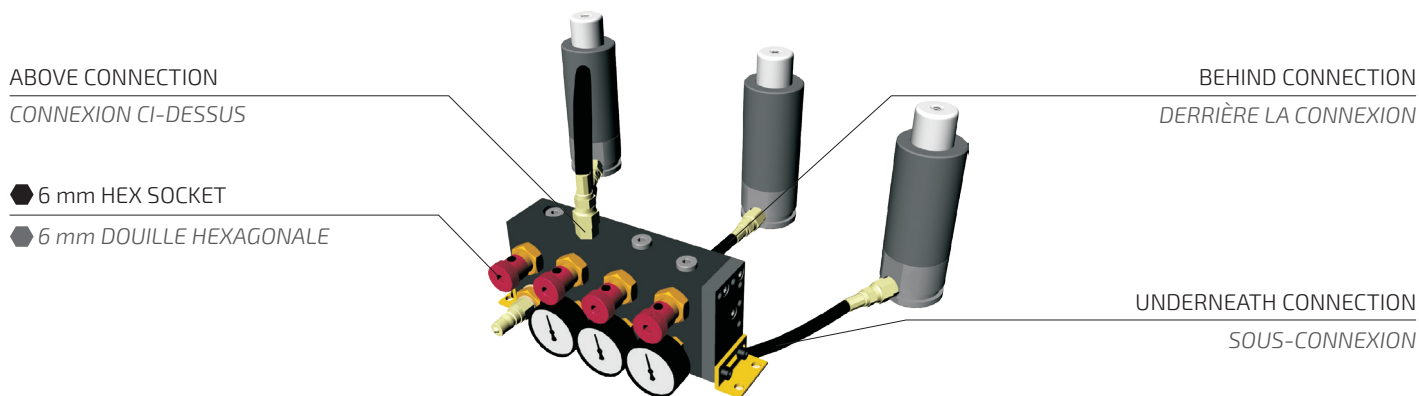

FIXING POSSIBILITIES / POSSIBILITES DE FIXATION

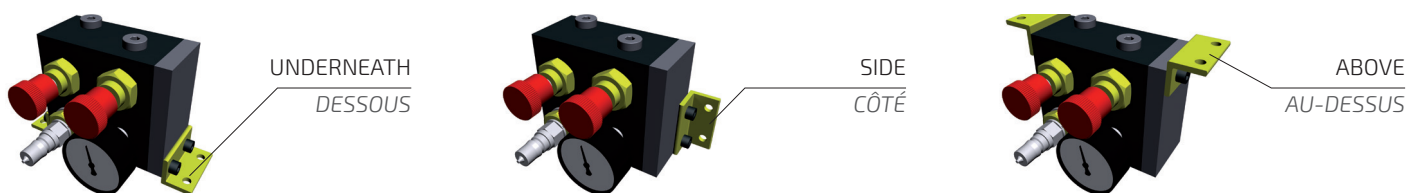

SAFETY PRESSURE SWITCHES

Pressostats de sécurité



DIGITAL Numérique

Digital pressure switch that can be set from 4 to 400 bar, available for the assembly on control panels.

Pressostat numérique réglable de 4 à 400 bar, disponible pour le montage sur les panneaux de commande.

TECHNICAL NOTES

- No. 2 PNP transistor switching outputs
- Switching current: max 250 mA per output
- Technical data sheet on request

NOTES TECHNIQUES

- N° 2 sorties de commutation de transistors PNP
- Courant de commutation : max 250 mA par sortie
- Fiche technique sur demande

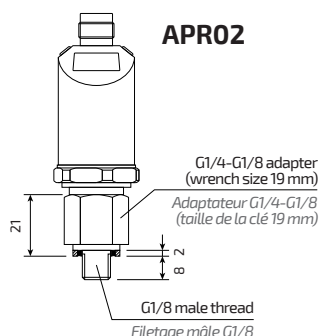
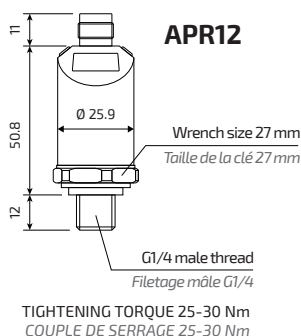
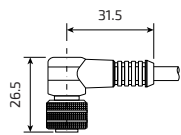

Model Modèle	Thread Filetage	Model Modèle
APR02	G1/8	RGV14
APR12	G1/4	

Swivel fitting for pressure switch orientation (for APR02 model: install between pressure switch body and G1/4-G1/8 adapter - see drawing)
Raccord pivotant pour l'orientation du pressostat (pour le modèle APR02 : installer entre le corps du pressostat et l'adaptateur G1/4-G1/8 - voir dessin)

ANALOG Analogique

Pressure switches, which can be set from 50 to 150-300 bar depending on model, available for the assembly on control panels.

Pressostats, qui peuvent être réglés de 50 à 150-300 bar selon le modèle, Disponible pour le montage sur les panneaux de commande.

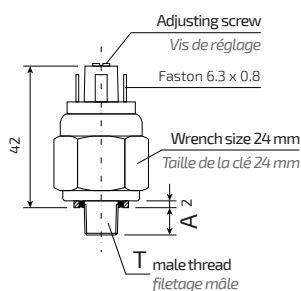

Model Modèle	T	Tightening torque Couple de serrage Nm	A mm	Range Gamme bar	Type Type	MAX voltage Tension MAX	MAX current Courant MAX
APR01A	G1/8	20-25	8	50-150	Normally open Normalement ouvert	48V ac/dc	0.5 A
APR01AN	G1/8	20-25	8	50-300	Normally open Normalement ouvert	48V ac/dc	0.5 A
APR11A	G1/4	25-30	10	50-150	Normally open Normalement ouvert	48V ac/dc	0.5 A
APR11AN	G1/4	25-30	10	50-300	Normally open Normalement ouvert	48V ac/dc	0.5 A

SAFETY VALVE

Soupape de sécurité



Overpressure safety valve, available for the assembly on control panels.

Soupape de sécurité contre surpression, disponible pour le montage sur les panneaux de commande.

TECHNICAL NOTES

- Nominal activation pressure: 500 bar
- In case of valve activation, contact Bordignon for reparation

NOTES TECHNIQUES

- Pression nominale d'activation : 500 bar
- En cas d'activation de la vanne, contacter Bordignon pour la réparation

Dimensions / Taille

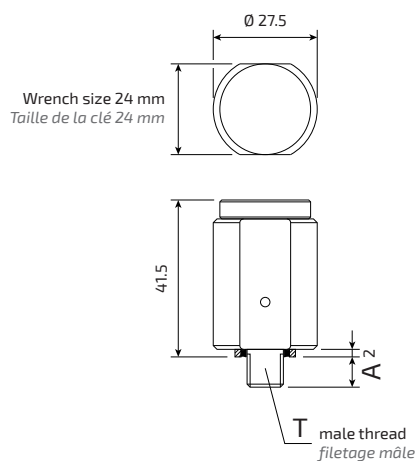

Model Modèle	T	Tightening torque Couple de serrage Nm	A mm
VS500	G1/8	20-25	8
VS500-1/4	G1/4	25-30	10

DISTRIBUTION BLOCKS

Blocs de distribution

The distribution blocks allow several gas springs to be connected in a battery.

Each block can connect several gas springs equipped with side port, and several blocks can be interconnected.

Choose the proper fittings for hose connection.

Les blocs de distribution permettent de connecter plusieurs ressorts à gaz dans une batterie.

Chaque bloc peut connecter plusieurs ressorts à gaz équipés d'un port latéral, et plusieurs blocs peuvent être interconnectés.

Choisissez les raccords appropriés pour le raccordement du tuyau.

Dimensions / Taille

Model
Modèle

AD00

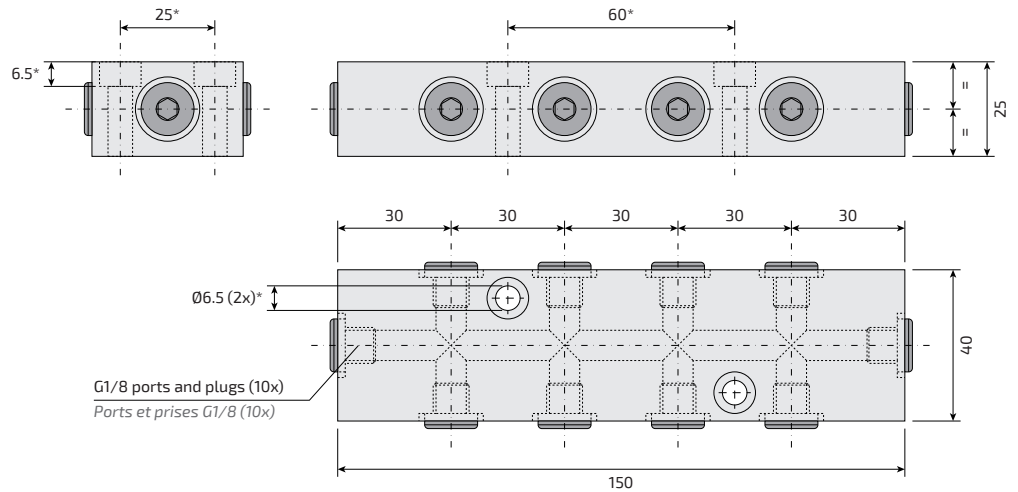

* For M6 fixing screws (2x) / Pour vis de fixation M6 (2x)

Model
Modèle

AD01

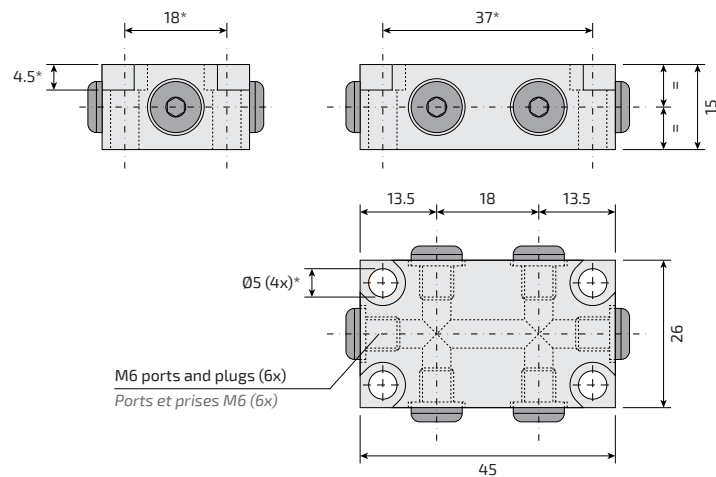

* For M4 fixing screws (4x) / Pour vis de fixation M4 (4x)



Model
Modèle

AD02

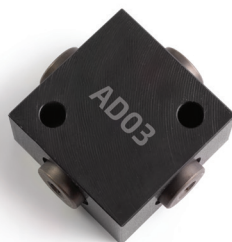

Model
Modèle

AD03



Model
Modèle

AD04

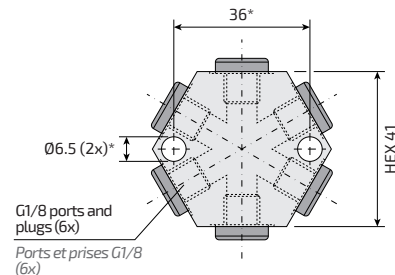
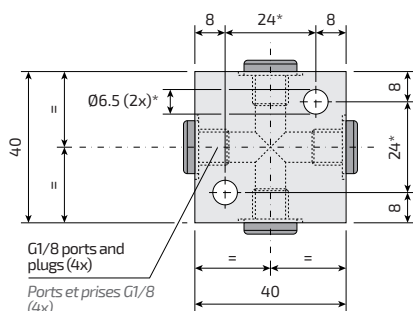
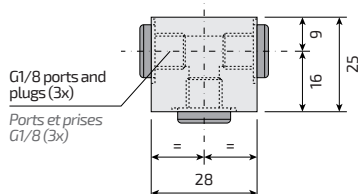
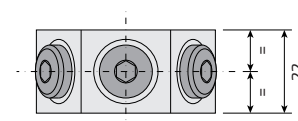
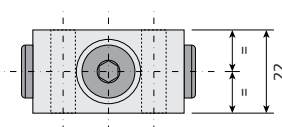
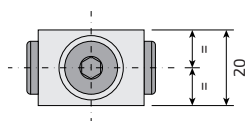

* For M6 fixing screws (2x) / Pour vis de fixation M6 (2x)

* For M6 fixing screws (2x) / Pour vis de fixation M6 (2x)

FITTINGS for CONNECTING SEVERAL DISTRIBUTION BLOCKS

Raccords pour connecter plusieurs de plusieurs blocs de distribution

Model
Modèle

AR000

Model
Modèle

AR000G

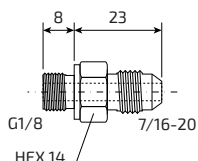

TIGHTENING TORQUE 20-25 Nm
COUPLE DE SERRAGE 20-25 Nm

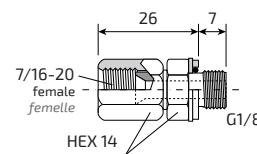

TIGHTENING TORQUE 20-25 Nm
COUPLE DE SERRAGE 20-25 Nm

(only for AD00 with G1/8 ports)
(uniquement pour AD00 avec ports G1/8)

(only for AD00 with G1/8 ports)
(uniquement pour AD00 avec ports G1/8)

CHARGING and DISCHARGING set

Kit de charge et de décharge



Complete series of charging unit, charging adapters and discharging devices, for both self-contained gas springs and control panels.

Série complète d'unités de charge, d'adaptateurs de charge et de dispositifs de décharge, pour les ressorts à gaz autonomes et les panneaux de commande.

Model
Modèle

COMPL

CHARGING UNIT

Unité de charge



This device allows to charge Bordignon self-contained gas springs and control panels with nitrogen gas.

Cet appareil permet de charger les ressorts à gaz autonomes et les panneaux de commande Bordignon avec de l'azote gazeux.

Specifications / Spécifications

Model
Modèle

CUC01

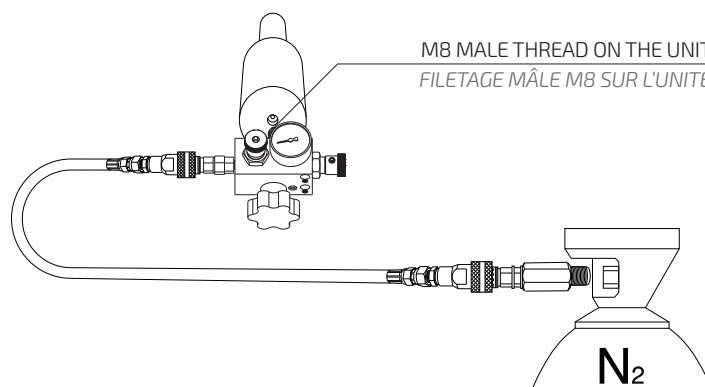

Model (optional)
Modèle (facultatif)

ATAP01

Extension hose (length: 2 metres) for an easier charging of control panels
Tuyau d'extension (longueur : 2 mètres) pour un chargement plus facile des panneaux de commande

Standard system (direct connection of charging unit CUC01 to control panel)

Système standard (connexion directe de l'unité de charge CUC01 au panneau de commande.)

(AN-1/4 charging adapter for control panels)
(Adaptateur de charge AN-1/4 pour panneaux de commande)

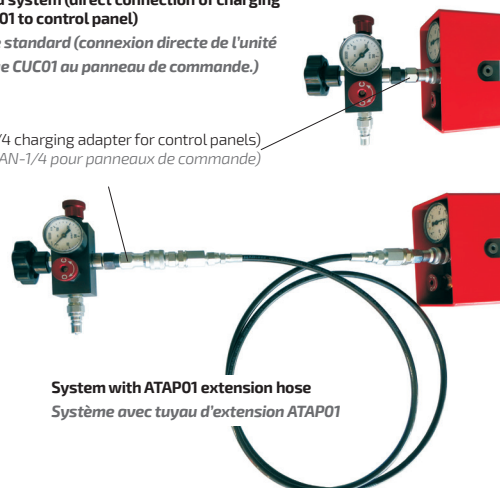

System with ATAP01 extension hose
Système avec tuyau d'extension ATAP01

CHARGING ADAPTERS







AUTOMOTIVE LINE

Adaptateurs de charge



Adapters for the nitrogen gas springs charging unit (only for gas springs with charging hole different from M8). Gas springs with charging hole M8 (not listed in table below) must be charged with CUC01 unit with no adapter.

Adaptateurs pour l'unité de charge des ressorts à gaz azoté (uniquement pour les ressorts à gaz avec trou de charge différent de M8). Les ressorts à gaz avec trou de charge M8 (non répertoriés dans le tableau ci-dessous) doivent être chargés avec une unité CUC01 sans adaptateur.

	Model Modèle	For gas spring models... Pour les modèles de ressorts à gaz...	Control panels Panneaux de commande
	AN-M4	EGS16, TGS700	-
	AN-M5	EGS24	-
	AN-M6	AGS170-AGS320, TGS400, VGS (all models), VV170, VV320-63/63H, VV320-80, VV500, VV565	-
	AN-M6/2	AGS350-AGS2400, IGS150-IGS250, PGS300-PGS500, VV2385	-
	AN-1/8	AGS4200-AGS20000, IGS500-IGS10000, LGS500, PGS750-PGS20000, VV750, VV2945	-
	AN-1/4	-	All models except "CV" versions Tous les modèles sauf les versions «CV»









DISCHARGING DEVICES

Dispositifs de décharge



Devices for discharging the nitrogen gas springs.

Dispositifs de décharge des ressorts à gaz à l'azote.

	Model Modèle	For gas spring models... Pour les modèles de ressorts à gaz...	Control panels Panneaux de commande
	ADS-M4/2	TGS700	-
	ADS-M4/3	EGS16	-
	ADS-M5/2	EGS24	-
	ADS-M6	TGS400	-
	ADS-M6/2	AGS170-AGS320	-
	ADS-M6/3	AGS350-AGS20000, IGS (all models), LGS500, PGS (all models), VV750, VV2385, VV2945	-
	ADS-M6/4	VGS (all models), VV170, VV320-63/63H, VV320-80, VV500, VV565	-
	ADS-M8	TGS1000-TGS20000	-

BOOSTER for NITROGEN N₂

Booster pour azote N₂



The Bordignon Booster is a pneumatic pump. By using compressed air, it increases the nitrogen N₂ pressure during the charging operation of gas springs for dies, in a safe and very precise way. Light and compact, the Bordignon Booster has a low compressed air consumption, resulting in savings of time and costs.

Le Booster Bordignon est une pompe pneumatique. En utilisant de l'air comprimé, il augmente la pression de l'azote N₂ pendant le fonctionnement de charge des ressorts à gaz pour matrices, de manière sûre et très précise. Léger et compact, le Booster Bordignon a une faible consommation d'air comprimé, ce qui permet un gain de temps et d'argent.

USE INSTRUCTIONS

- Connect nitrogen N₂ tank (pressure: minimum 20 bar / maximum 220 bar) to the Booster (it's necessary to have the hose model ATBOOSTER).
- Connect Booster to the nitrogen gas spring (it's necessary to have the charging set mod. COMPL).
- Connect the compressed air (max pressure 8 bar; use lubricated air when working continuously for more than 30 minutes).
- Turn off the discharging valve.
- Turn on the charging valve of the Booster.
- Turn on the compressed air and slowly turn on nitrogen N₂ tank.
- When the nitrogen gas spring has reached the required pressure, turn the charging valve off, turn on discharging valve and disconnect the nitrogen gas spring.
- Once finished, turn off both the compressed air and the nitrogen N₂ tank.

MODE D'EMPLOI

- Connectez le réservoir d'azote N₂ (pression : minimum 20 bar / maximum 220 bar) au Booster (il est nécessaire d'utiliser le flexible modèle ATBOOSTER).
- Connecter le booster au ressort à gaz à l'azote (il est nécessaire d'avoir le kit de charge mod. COMPL).
- Connecter l'air comprimé (pression maximale de 8 bar ; utilisez de l'air lubrifié lorsque vous travaillez en continu pendant plus de 30 minutes).
- Fermez la vanne de décharge.
- Allumez la soupape de charge du Booster.
- Allumez l'air comprimé et allumez lentement le réservoir d'azote N₂.
- Lorsque le ressort à gaz azoté a atteint la pression requise, fermez la soupape de charge, allumez la soupape de décharge et débranchez le ressort à gaz azoté.
- Une fois terminé, éteignez à la fois l'air comprimé et le réservoir d'azote N₂.

⚠ ATTENTION! USE NITROGEN N₂ ONLY

⚠ ATTENTION! N'UTILISEZ QUE DE L'AZOTE N₂

Dimensions / Taille

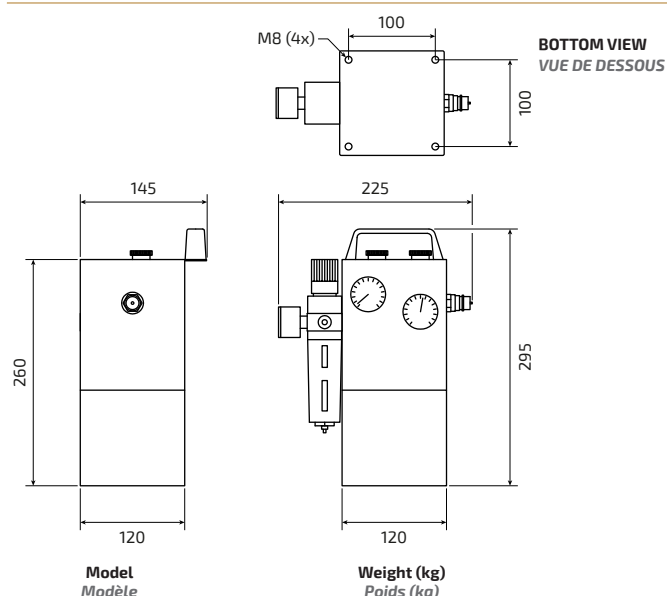

BOOSTER

9.5

COMPONENTS / COMPOSANTS

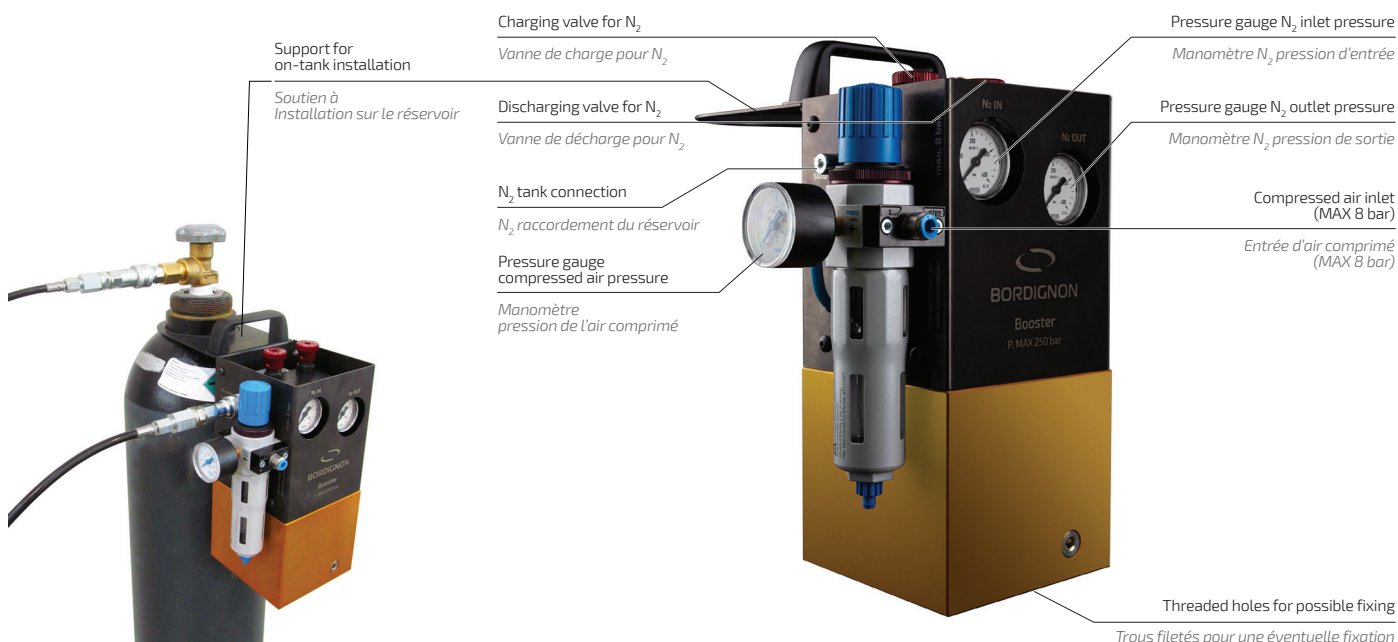

The support for on-tank installation is always supplied together with the BOOSTER as a separate component. To install it on the BOOSTER: unscrew the handle, fit the support, screw the handle back on.

Le support pour l'installation sur la cuve est toujours fourni avec le BOOSTER en tant que composant séparé. Pour l'installer sur le BOOSTER : dévisser la poignée, monter le support, revisser la poignée.

OPERATING SCHEME / SCHÉMA DE FONCTIONNEMENT

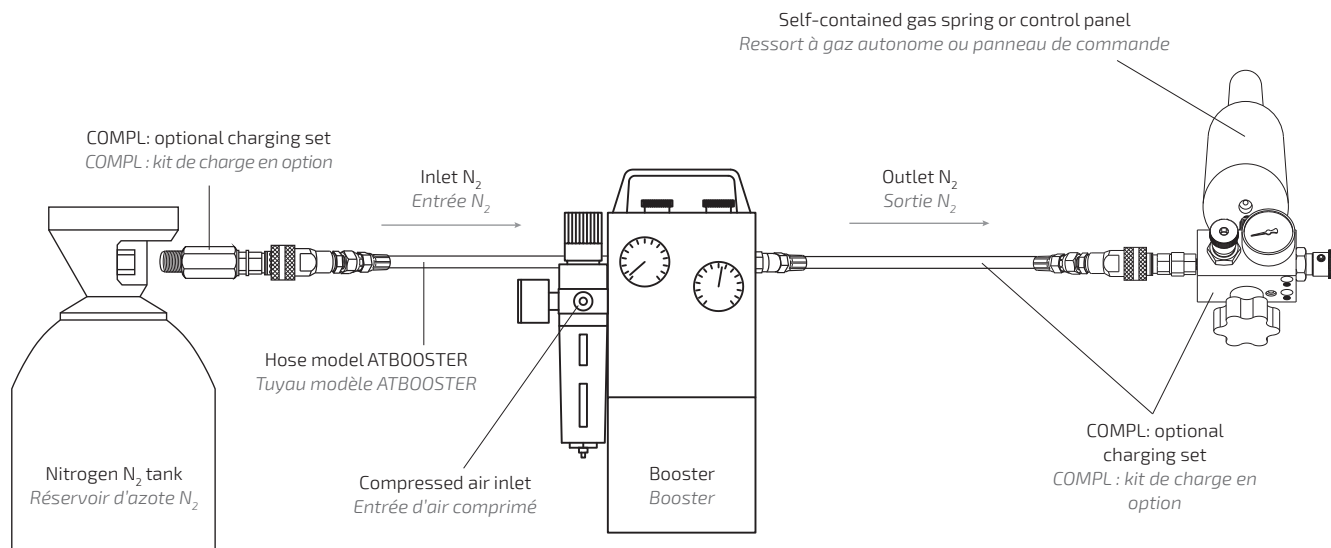

MAX reachable outlet nitrogen pressure in relation to the compressed air pressure
 Pression d'azote de sortie MAX accessible par rapport à la pression de l'air comprimé

Compressed air pressure (bar) Pression de l'air comprimé (bar)	7	4	2
N ₂ max outlet pressure (bar) N ₂ pression de sortie maximale (bar)	220	125	60

PRESSURE REGULATOR

AUTOMOTIVE LINE

Régulateur de pression

Pressure regulator for nitrogen N₂ gas.

Régulateur de pression pour gaz azote N₂

Specifications / Spécifications

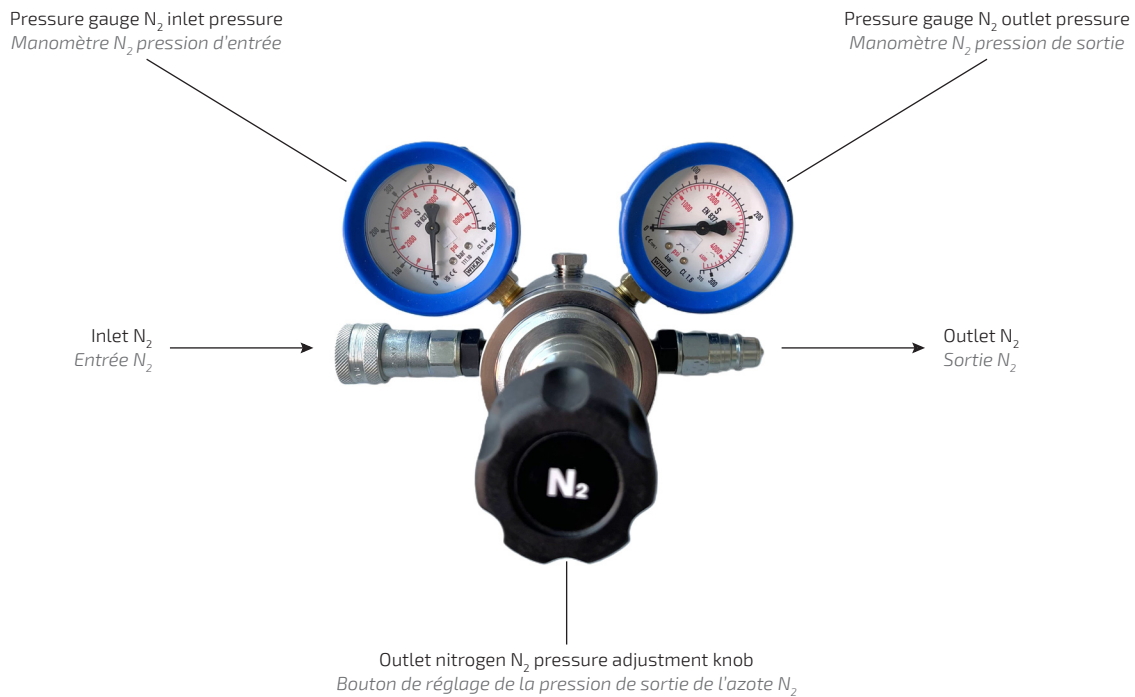

Model Modèle	MAX inlet N ₂ pressure Pression d'entrée maximale N ₂ bar	Outlet range pressure Pression de sortie bar	Inlet Crique	Outlet Débouché
REG220	300	20-220	Bordignon-standard quick coupling (female) Raccord rapide standard Bordignon (femelle)	Bordignon-standard quick coupling (male) Raccord rapide standard Bordignon (vis mâle)

 ATTENTION! USE NITROGEN N₂ ONLY

 ATTENTION! N'UTILISEZ QUE DE L'AZOTE N₂

USE EXAMPLES / EXEMPLES D'UTILISATION

Pressure regulator on Booster outlet
Régulateur de pression à la sortie du booster

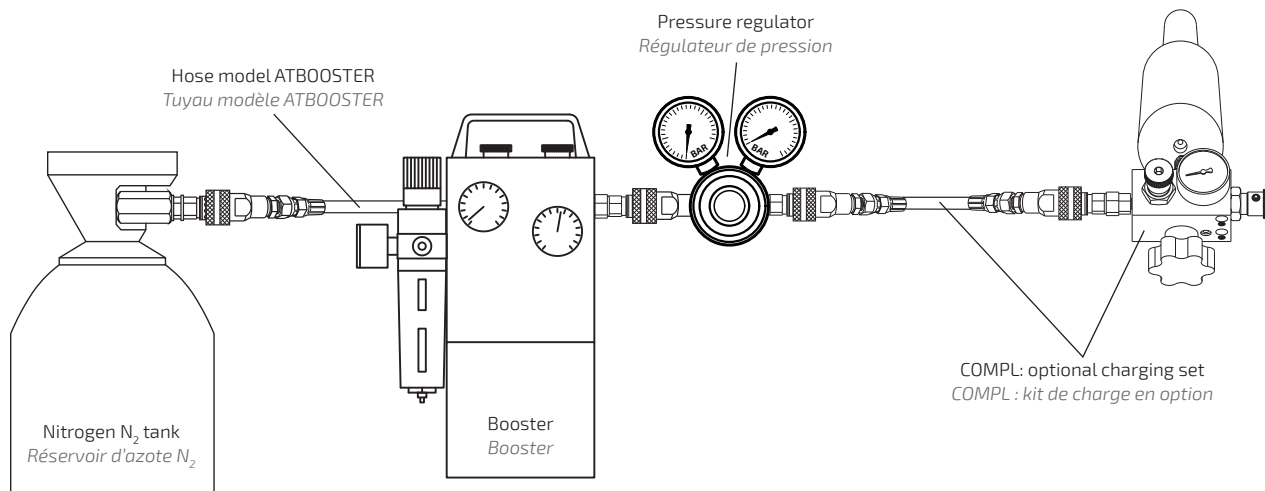

Pressure regulator on nitrogen N₂ tank
Régulateur de pression sur réservoir d'azote N₂

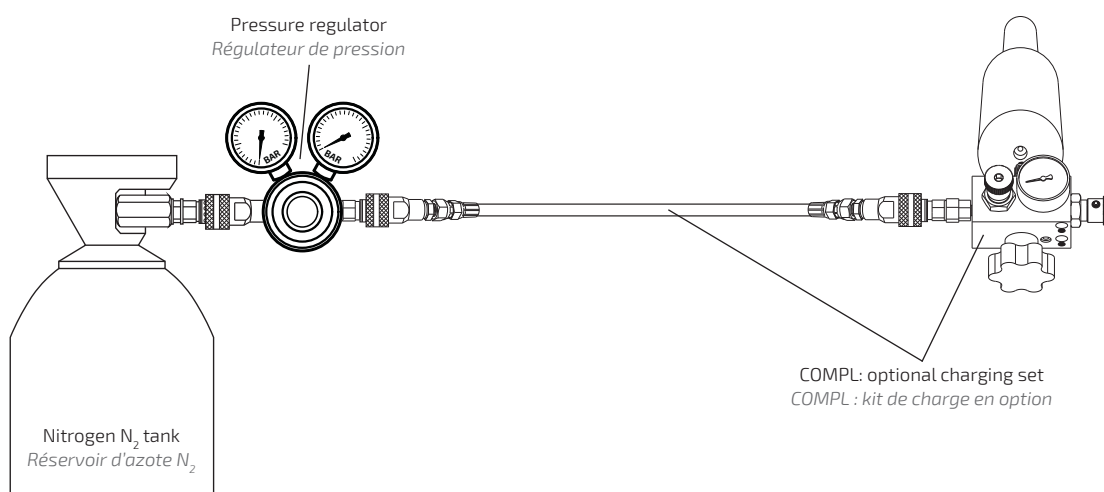

OV GAS SPRING SYSTEM (ALTERNATIVE MANIFOLD)

Système de ressort à gaz OV (collecteur alternatif)

Valveless nitrogen gas springs for an **alternative manifold connection ("OV system")**:

- Use of standard gas springs, fast delivery!
- Lower manufacturing and maintenance costs than traditional manifold plates and dedicated manifold gas springs
- More compact plate dimensions
- Simple gas spring fixing with through-plate screws
- OV gas springs available strokes, dimensions, and the other specifications not listed on the next page, are the same as the corresponding standard models (example: the unlisted specifications of model AGS1000-50-A-OV are the same as model AGS1000-50-A)

Ressorts à gaz à l'azote sans soupape pour un **raccord de collecteur alternatif («système OV»)**:

- Utilisation de ressorts à gaz standard, livraison rapide !
- Coûts de fabrication et de maintenance inférieurs à ceux des plaques de collecteur traditionnelles et des ressorts à gaz de collecteur dédiés
- Dimensions de plaque plus compactes
- Fixation simple du ressort à gaz avec des vis traversantes
- Les courses disponibles, les dimensions et les autres spécifications non répertoriées à la page suivante sont les mêmes que celles des modèles standard correspondants (exemple : les spécifications non répertoriées du modèle AGS1000-50-A-OV sont les mêmes que celles du modèle AGS1000-50-A)

TECHNICAL NOTES

• OV gas springs use instructions:

- Mounting instructions on the next page
 - Use instructions, information and catalogue help: see dedicated catalogue section
 - Cycles per minute MAX: see specifications tables for the corresponding standard model
- Plate material requirements:
 - Resilience KV ≥ 27 J (at 0°C)
 - Elongation at break A $\geq 14\%$
 - Respect national regulations about pressure equipment
 - Minimum plate thickness = 25 mm

NOTES TECHNIQUES

• Instructions d'utilisation des ressorts à gaz OV :

- Instructions de montage sur la page suivante
 - Instructions d'utilisation, informations et aide au catalogue : Voir la section dédiée au catalogue
 - Cycles par minute MAX : voir les tableaux de spécifications du modèle standard correspondant
- Exigences relatives au matériau de la plaque :
 - Résilience KV ≥ 27 J (à 0°C)
 - Allongement à la rupture A $\geq 14\%$
 - Respecter les réglementations nationales relatives aux équipements sous pression
 - Épaisseur minimale de la plaque = 25 mm



USE EXAMPLES

- A** OV gas springs and OV control panel fixed on a single low-thickness plate, without connection hoses.
- B** OV gas springs fixed on smaller plates connected by hoses, and standard control panel connected by hose.

EXEMPLES D'UTILISATION

- A** Ressorts à gaz OV et panneau de commande OV fixés sur une seule plaque de faible épaisseur, sans tuyaux de raccordement.
- B** Ressorts à gaz OV fixés sur des plaques plus petites reliées par des tuyaux, et panneau de commande standard relié par un tuyau.

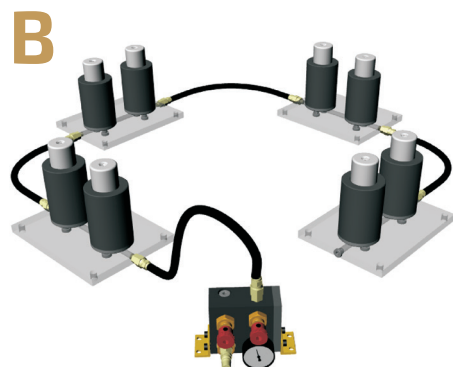

OV CONTROL PANELS & OTHER ACCESSORIES FOR OV SYSTEM

See further on in this catalogue.

PANNEAUX DE CONTRÔLE OV ET AUTRES ACCESSOIRES POUR SYSTÈME OV

Voir plus loin dans ce catalogue.

OV GAS SPRINGS



This gas spring series includes the models compliant with automotive standards /
La série de ressorts à gaz comprend les modèles conformes aux normes autos

VW 39D 22100

Ressorts à gaz OV

GENERAL FEATURES / CARACTÉRISTIQUES GÉNÉRALES

In comparison with the corresponding standard models, OV gas springs are valveless (no side port), they have a bottom hole for direct connection (OR-sealed) to manifold plate, and they do not feature the bottom (square) groove.

Par rapport aux modèles standard correspondants, les ressorts à gaz OV sont sans soupape (sans orifice latéral), ils ont un trou inférieur pour une connexion directe (scellé OR) à la plaque du collecteur, et ils ne comportent pas de rainure inférieure (carrée).

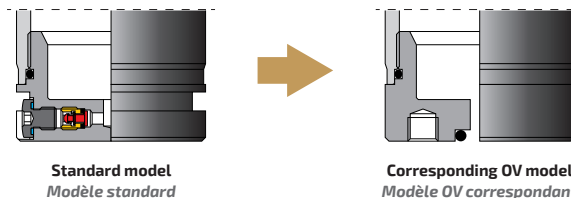

MOUNTING AND TECHNICAL SPECIFICATIONS / MONTAGE ET SPÉCIFICATIONS TECHNIQUES

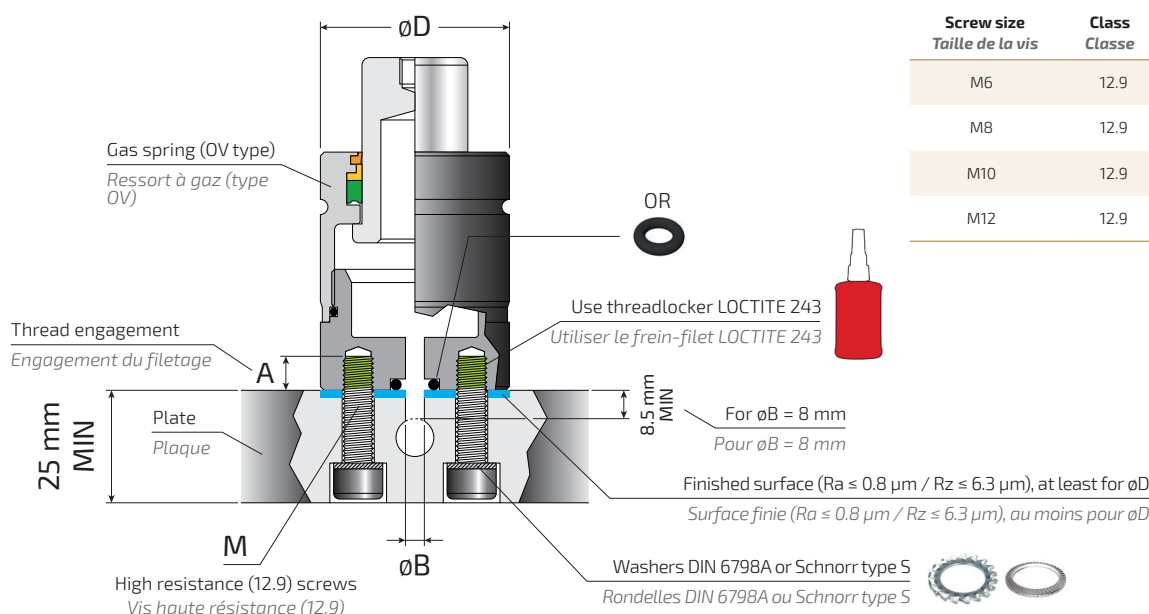

Screw size Taille de la vis	Class Classe	Tightening torque Couple de serrage
M6	12.9	10.5 Nm
M8	12.9	26 Nm
M10	12.9	51 Nm
M12	12.9	89 Nm

Models Modèles	Ø D (MIN) mm	Ø B ± 0.1 mm	M	A ● mm	OR ● NBR 90 Sh. A
AGS 350-...-A-OV	32	5	M6	6	2025-010 (6.07 x 1.78)
AGS 500-...-A-OV	38	5	M6	6	2025-010 (6.07 x 1.78)
AGS 750-...-A-OV	45	5	M8	6	2025-010 (6.07 x 1.78)
AGS 1000-...-A-OV	50	5	M8	6	2025-010 (6.07 x 1.78)
AGS 1200-...-A-OV	50	5	M8	6	2025-010 (6.07 x 1.78)
AGS 1500-...-A-OV	63	5	M8	6	2025-010 (6.07 x 1.78)
AGS 2400-...-A-OV	75	5	M8	6	2025-010 (6.07 x 1.78)
AGS 4200-...-A-OV	95	8	M8	12	112-613 (9.92 x 2.62)
AGS 6600-...-A-OV	120	8	M10	12	112-613 (9.92 x 2.62)
AGS 9500-...-A-OV	150	8	M10	16	112-613 (9.92 x 2.62)
AGS 20000-...-A-OV	195	8	M12	18	112-613 (9.92 x 2.62)

● Number and layout of the threaded holes on the gas springs base: see corresponding standard models.
Nombre et disposition des trous filetés sur la base des ressorts à gaz : voir les modèles standard correspondants.

● The thread engagement length **A** is the maximum available thread depth. Do not use thread engagement lengths < **A**.
La longueur d'engagement du filetage **A** est la longueur maximale disponible profondeur du fil. N'utilisez pas de longueurs d'engagement de filetage < **A**.

● 1 pc. OR is supplied with each OV gas spring
1 pièce OR est fourni avec chaque ressort à gaz OV

APV...CV / APV... CONTROL PANEL FOR OV SYSTEM

Panneau de commande APV...CV / APV... pour système OV



This panel allows to charge and discharge a manifold plate ("OV system" or other) using a direct-coupling to the plate (no need for hoses).

Ce panneau permet de charger et de décharger une plaque collectrice (« système OV » ou autre) à l'aide d'un couplage direct à la plaque (pas besoin de durites).

CONFIGURATIONS AND DIMENSIONS / CONFIGURATIONS ET DIMENSIONS

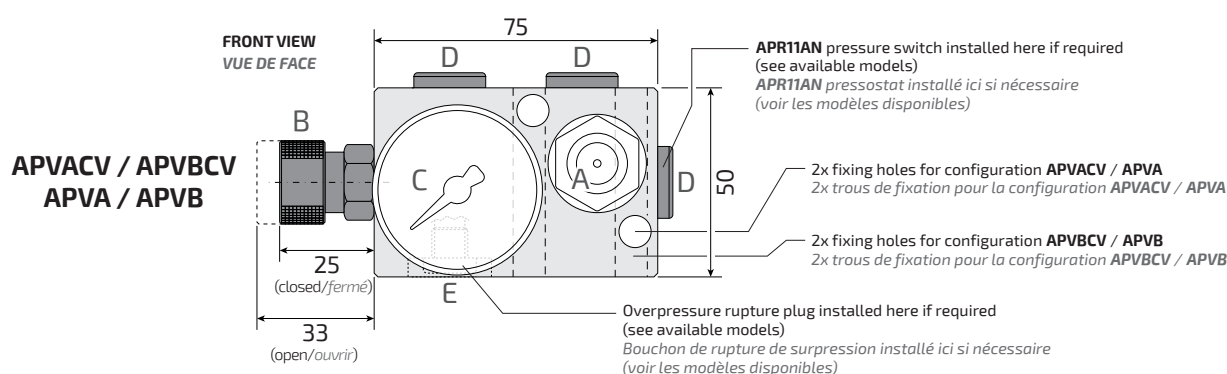

Configuration for model APVACV / APVA Configuration pour le modèle APVACV / APVA

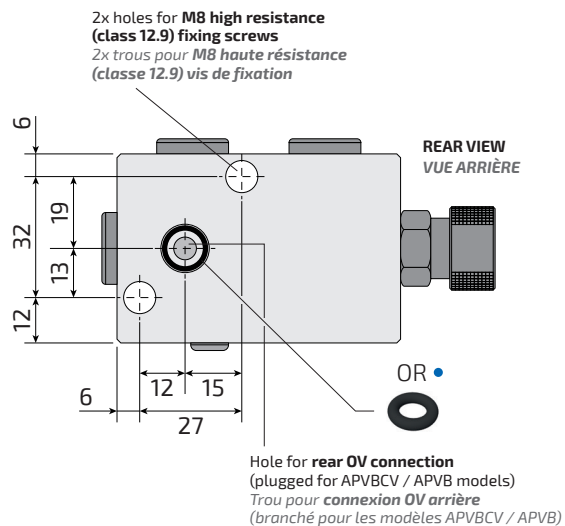

Configuration for model APVBCV / APVB Configuration pour le modèle APVBCV / APVB

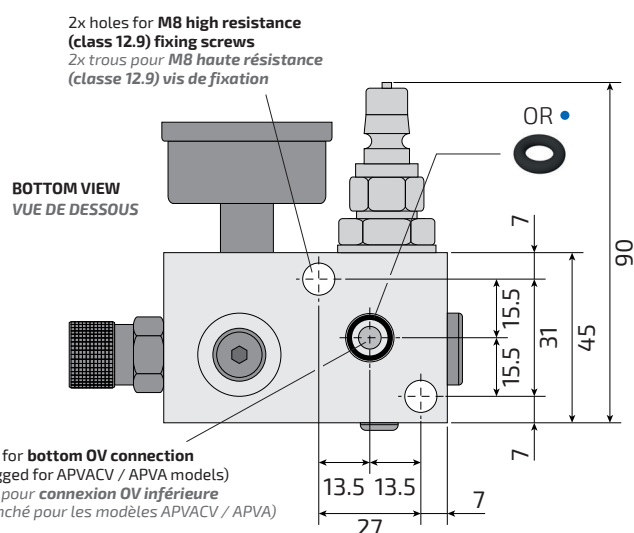

Model / Modèle	Model / Modèle	Description
APVACV	APVA	Control panel for OV system with rear direct-connection to plate / Panneau de commande pour système OV avec connexion directe arrière à la plaque
APVBCV	APVB	Control panel for OV system with bottom direct-connection to plate / Panneau de commande pour système OV avec connexion directe en bas à la plaque
APVAPANCV / APVBPANCV	APVAPAN / APVBPAN	Control panel for OV system with APR11AN pressure switch (50-300 bar normally open) / Panneau de commande pour système OV avec pressostat APR11AN (50-300 bar normalement ouvert)
APVARPCV / APVBRPCV	APVARP / APVBRP	Control panel for OV system with overpressure rupture plug / Panneau de commande pour système OV avec bouchon de rupture de surpression
APVAFCV / APVBFCV	APVAF / APVBF	Control panel for OV system with APR11AN pressure switch (50-300 bar normally open) and with overpressure rupture plug / Panneau de commande pour système OV avec pressostat APR11AN (50-300 bar normalement ouvert) et avec bouchon de rupture de surpression

All models are available with safety valve V5500 already assembled (on request). / Tous les modèles sont disponibles avec la soupape de sécurité V5500 déjà montée (sur demande).



Most used
Le plus utilisé

APV...CV



CEJN 10 358

APV...



Bordignon-standard
Standard Bordignon

TECHNICAL NOTES

- A** **Charging valve:**
- **APV...CV:** CEJN-type, compatible with most non-Bordignon charging systems
 - **APV...:** Bordignon-standard, to be used only with CUC01 or COMPL or BOOSTER
- B** Discharging valve
- C** Pressure gauge
- D** No. 3 connection ports G1/4
- E** No. 1 connection port G1/8
- The connection ports are plugged
 - No. 2 fixing holes for M8 high resistance (12.9) hex-socket screws

ATTENTION! USE NITROGEN N₂ ONLY

NOTES TECHNIQUES

- A** **Valve de charge:**
- **APV...CV:** Type CEJN, compatible avec la plupart des systèmes de charge non Bordignon
 - **APV...:** Standard Bordignon, à utiliser uniquement avec CUC01, COMPL ou BOOSTER
- B** Vanne de décharge
- C** Manomètre
- D** N° 3 ports de connexion G1/4
- E** N° 1 port de connexion G1/8
- Les ports de connexion sont bouchés
 - N° 2 trous de fixation pour vis à six pans creux hexagonaux M8 haute résistance (12.9)

ATTENTION! N'UTILISEZ QUE DE L'AZOTE N₂

APVACV / APVA MOUNTING
MONTAGE APVACV / APVA

APVACV / APVA

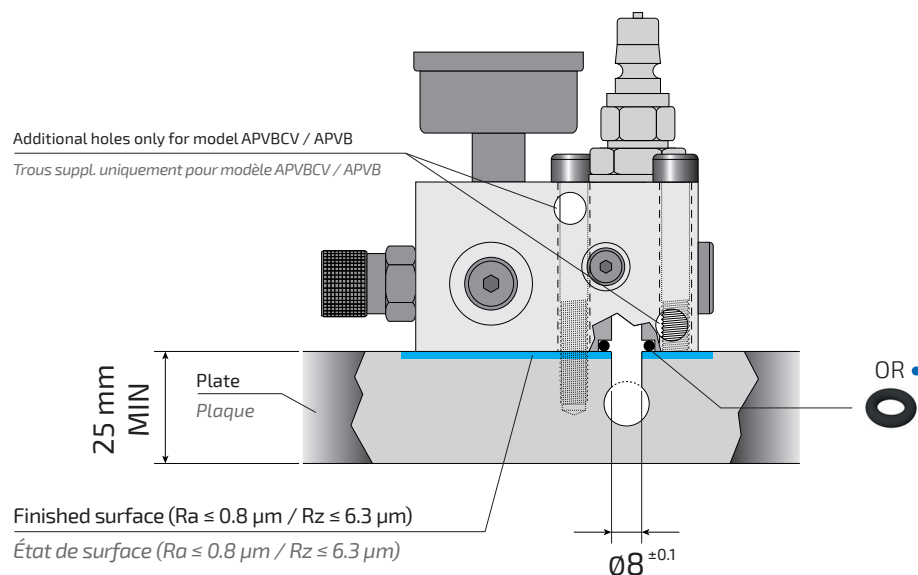

• 1 pc. OR NBR 90 Shore A model 2037-012 (9.25 x 1.78 mm) is supplied with the control panel / 1 pièce OR NBR 90 Shore Un modèle 2037-012 (9.25 x 1.78 mm) est fourni avec le panneau de commande

APVBCV / APVB MOUNTING
MONTAGE APVBCV / APVB

APVBCV / APVB

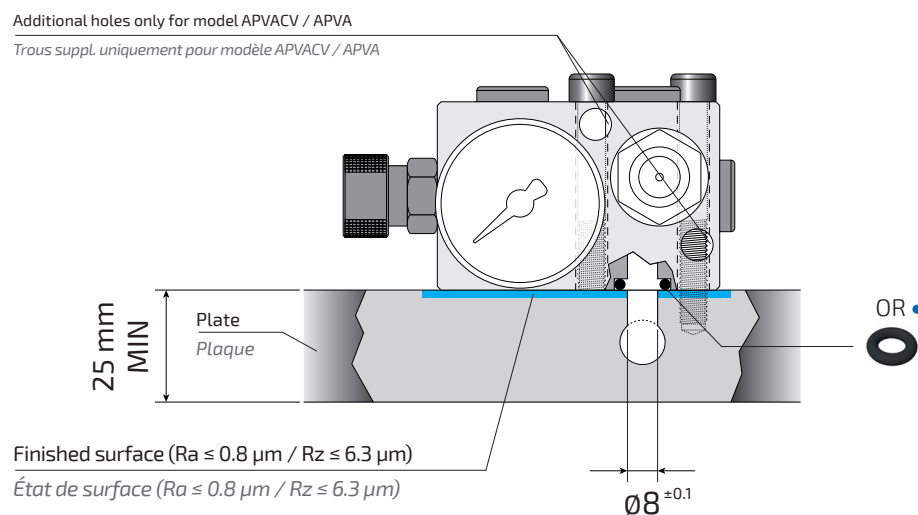

• 1 pc. OR NBR 90 Shore A model 2037-012 (9.25 x 1.78 mm) is supplied with the control panel / 1 pièce OR NBR 90 Shore Un modèle 2037-012 (9.25 x 1.78 mm) est fourni avec le panneau de commande

HOSE CRIMPING DEVICE

Dispositif de sertissage de tuyaux



Portable hand-operated hose crimping device designed for Bordignon fittings and hoses. Lightweight, compact, and easy to use, it is ideal for carrying out on-site operations. Supplied complete with accessories and use instructions.

Dispositif portable manuel de sertissage de tuyaux conçu pour les raccords et tuyaux Bordignon. Léger, compact et facile à utiliser, il est idéal pour les interventions sur site. Fourni complet avec accessoires et instructions d'utilisation.

Model Modèle	Weight (kg) Poids (kg)	Dimensions ↔ × ↗ × ⇅ (mm) Taille ↔ × ↗ × ⇅ (mm)
CR01M	23	330 x 490 x 210

HCA



This series includes the models compliant with automotive standards /
Série de modèles conformes aux normes automobiles

BMW	MB	VW
FCA	Renault	Volvo

Counter plate / Contre-plaque

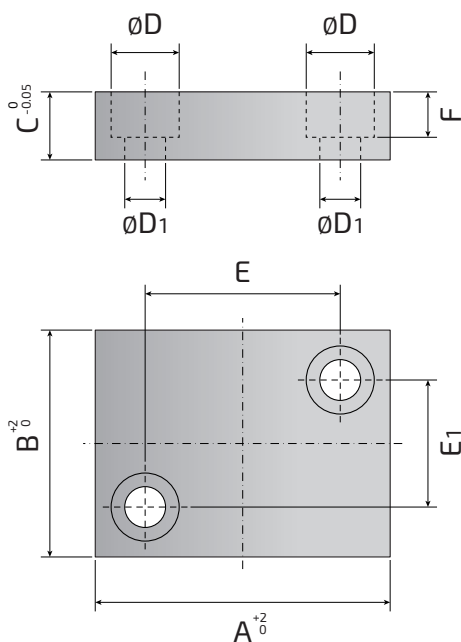

Hardened steel
Acier trempé

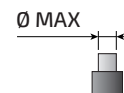

For gas springs with piston rod diameter MAX
Pour les ressorts à gaz avec diamètre de la tige de piston

Model Modèle	Reference to Standards Référence aux normes	A mm	B mm	C mm	$\varnothing D$ mm	$\varnothing D_1$ mm	E mm	E1 mm	F mm	MAX mm
HCA 4040A	VDI 3003, FCA	40	40	15	15	9	21	21	10	20
4040B	BMW, VW	40	40	12	11	7	24	24	7	20
4040C	-	40	40	15	11	7	24	24	7	20
5656	FCA, Renault	56	56	20	18	11	32	32	13	36
6060A	BMW, VW	60	60	15	15	9	40	40	9	36
6060B	MB	60	60	12	14	9	38	38	9	36
7070	VDI 3003, BMW, VW	70	70	15	15	9	50	50	9	60
7171	FCA	71	71	20	18	11	48	48	13	60
8080	Volvo	80	80	16	15	9	62	0	10	65
9090A	-	90	90	12	15	9	64	64	9	80
9090B	VDI 3003	90	90	15	15	9	70	70	9	80
9090C	FCA, Renault, Volvo	90	90	20	18	11	67	67	13	80
9090D	MB	90	90	12	14	9	70	70	9	80
100100A	Volvo	100	100	16	15	9	82	0	10	90
100100B	BMW, VW	100	100	20	18	11	74	74	11	90
100100C	MB	100	100	12	14	9	81	81	9	90
140140A	VW	140	140	20	18	11	110	110	11	130
140140B	FCA, Renault	140	140	20	18	11	110	110	13	130
5025	VDI 3003, FCA	50	25	12	11	7	32	8	8	15
5030	FCA	50	30	12	11	7	40	14	8	20
5030A	FCA	50	30	12	11	7	35	14	7	20
5530	VDI 3003	55	30	12	11	7	40	14	8	20
5532	Volvo	55	32	16	15	9	37	0	10	20
6550	Volvo	65	50	16	15	9	47	0	10	36
7035	VDI 3003, FCA	70	35	15	15	9	48	14	10	30
7550	VDI 3003, FCA	75	50	15	15	9	56	30	10	36
8060	Volvo	80	60	16	15	9	62	0	10	55
8560A	FCA	85	60	15	15	9	56	40	10	55
8560B	VDI 3003	85	60	15	15	9	66	40	10	55
10080	VDI 3003, FCA	100	80	20	18	11	72	56	12	70
110100	FCA	110	100	20	18	11	85	75	12	100

Use example / Utiliser l'exemple

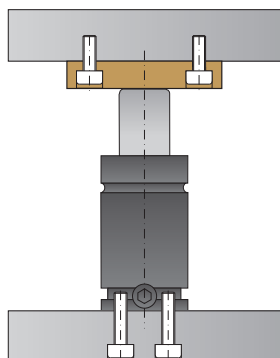

LUBRICATION GREASE

AUTOMOTIVE LINE

Graisse de lubrification



It is necessary to keep the piston rod lubricated for a longer life of the gas spring. We can supply grease with molybdenum disulfide in 600 g cartridges.

Il est nécessaire de maintenir la tige du piston lubrifiée afin d'assurer une plus longue durée de vie du ressort à gaz. Nous pouvons fournir de la graisse au disulfure de molybdène en cartouches de 600 g.

Model
Modèle

PLUB2

DEVICE for the NITROGEN GAS SPRINGS INITIAL LOAD CHECK

Dispositif pour le contrôle initial de la charge des ressorts à gaz d'azote



This device is a load gauge for nitrogen gas springs. This device is usually used to measure the initial force of nitrogen gas springs, in order to verify that they are actually charged.

Cet appareil est un jauge de charge pour les ressorts à gaz azoté. Cet appareil est généralement utilisé pour mesurer la force initiale des ressorts à gaz azoté, afin de vérifier qu'ils sont réellement chargés.

Model
Modèle

AK2

Hydraulic force-measuring device MAX 12000 daN
Appareil de mesure de force hydraulique MAX 12000 daN

- Load cells have to be ordered separately (see below)
Les capteurs de force doivent être commandés séparément (voir ci-dessous)



Model Modèle	
AH1000	Analog load cell 100-1000 daN Capteur de force analogique 100-1000 daN
AH4000	Analog load cell 400-4000 daN Capteur de force analogique 400-4000 daN
AH10000	Analog load cell 1000-10000 daN Capteur de force analogique 1000-10000 daN
Model Modèle	
AHD1000	Digital load cell 100-1000 daN Capteur de force numérique 100-1000 daN
AHD5000	Digital load cell 500-5000 daN Capteur de force numérique 500-5000 daN
AHD10000	Digital load cell 1000-10000 daN Capteur de force numérique 1000-10000 daN
Model Modèle	
AHD1000T630	Digital load cell 100-1000 daN with hose L = 630 mm Capteur de force numérique 100-1000 daN avec tuyau L = 630 mm
AHD5000T630	Digital load cell 500-5000 daN with hose L = 630 mm Capteur de force numérique 500-5000 daN avec tuyau L = 630 mm
AHD10000T630	Digital load cell 1000-10000 daN with hose L = 630 mm Capteur de force numérique 1000-10000 daN avec tuyau L = 630 mm



Model
Modèle

AHDTFX

Fixing bracket for load cells with hose
Support de fixation pour capteurs de force avec tuyau



- Different hose lengths available on request: 300 mm (models: AHD...T300), 500 mm (models: AHD...T500), 1000 mm (models: AHD...T1000)
Différentes longueurs de tuyau disponibles sur demande: 300 mm (modèles: AHD...T300), 500 mm (modèles: AHD...T500), 1000 mm (modèles: AHD...T1000)



BORDIGNON

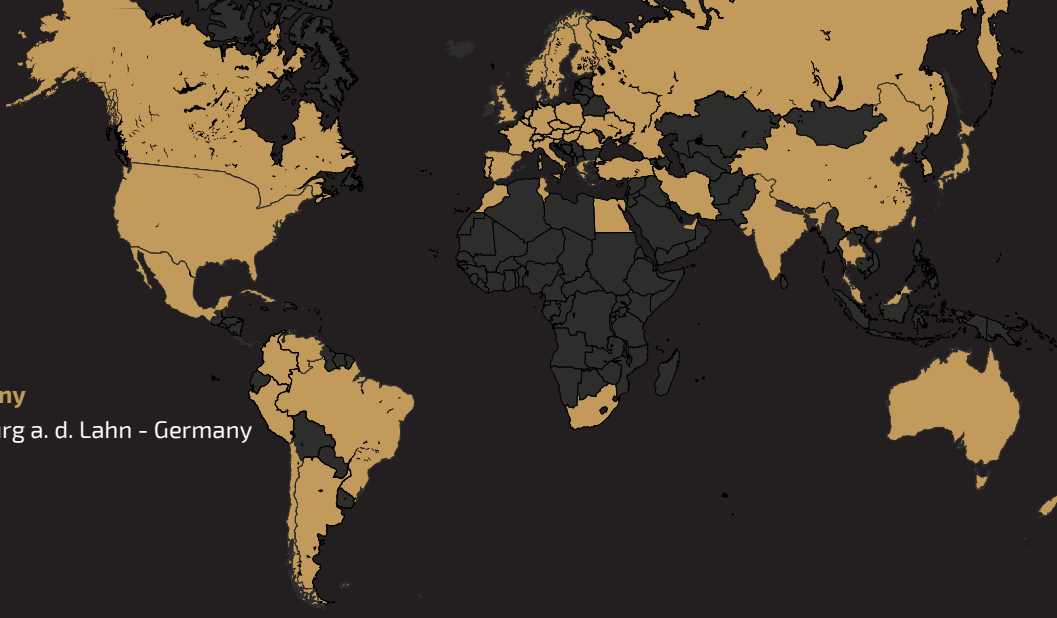

SF BORDIGNON GmbH

Sales office and warehouse in Germany

Justus-Staudt-Straße, 2 - 65555 Limburg a. d. Lahn - Germany
T +49-(0)6431-212149-0
info@sf-bordignon.com
www.sf-bordignon.com

BORDIGNON SRL

Sales office and warehouse in Italy

Via Volta, 20 - 36028 Rossano Veneto (VI) - Italy
T +39 0424 36157
bordignon@bordignon.com
www.bordignon.com

BORDIGNON SRL

Registered office in Italy

Via Volta, 2 - 36028 Rossano Veneto (VI) - Italy
T +39 0424 219701
bordignon@bordignon.info

BORDIGNON SRL *

Production / Technical office in Italy

Zona Industriale, 5A - 38055 Grigno (TN) - Italy
T +39 0461 765488
bordignon@bordignon.info

Bordignon Srl reserves the right to make modifications to the technical data of this catalogue, without prior notice.
Bordignon Srl se réserve le droit d'apporter des modifications aux données techniques de ce catalogue, sans préavis.



* ISO 9001 certificate available for download on www.bordignon.com
Certificat ISO 9001 disponible en téléchargement sur www.bordignon.com

DEALER
REVENDEUR



© 2026 Bordignon Srl File: Bordignon Automotive Line 0626 EN-FR

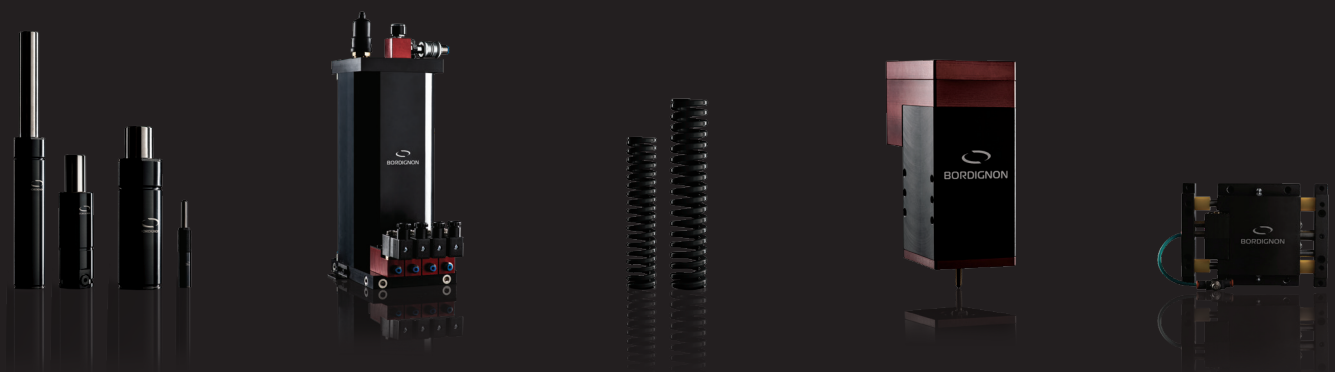

Find our products catalogues online - Retrouvez nos catalogues de produits en ligne www.bordignon.com